

MICRONIZATION OF MEASLES VACCINE AND siRNA BY CAN-BD FOR AEROSOL DELIVERY BY AIR EXPANSION OF POWDERS WITH A PUFFHALER™

Robert E. Sievers^{1,2}, David J. Bennett¹, Stephen P. Cape^{1,2}, Chad S. Braun², Jessica A. Best^{1,2}, Andrea L. Morin¹, Chris A. Pelzmann¹, Brian P. Quinn¹, Pankaj Pathak¹, Jim A. Searles¹, Pradnya A. Bhagwat¹, Lia G. Rebets¹, Jessica L. Burger², David H. McAdams²



¹ AKTIV-DRY, 6060 Spine Road, Boulder, CO 80301; ² Center for Pharmaceutical Biotechnology, Dept. of Chemistry and Biochemistry, and CIRES, University of Colorado at Boulder, Boulder, CO 80309-0214



INTRODUCTION

Powders produced by CO₂-Assisted Nebulization with a Bubble Dryer® (CAN-BD) are used in developing the PuffHaler™, an inexpensive air-activated dry powder inhaler (DPI) (1) that utilizes silicone rubber pressure release valves. This active inhaler incorporates a detachable holding chamber and mask to make the aerosol cloud available to infants, toddlers and uncooperative subjects who cannot use a passive DPI.

METHODS

Dry powders of measles vaccine formulations and siRNA were prepared by CAN-BD (2-7) at 50 °C. Fine particle fractions (FPF) of live virus and placebo powders delivered from the Aerolizer (Schering) were measured using an Andersen Cascade Impactor (ACI). Performance of the Puffhaler system using placebo powders, as measured by FPF and emitted dose (ED), was characterized at adult flow rates as well as infant respiratory patterns using a variant of the method described by Janssens *et al.* (8). Water content was measured by Karl Fischer coulometric titration. Measles vaccine potency was measured by a standard plaque assay (9). Material and particle crystallinity was analyzed using powder X-ray diffraction. Material and particle glass transition temperatures were determined using a Perkin-Elmer, Diamond Differential Scanning Calorimeter (DSC).

PUFFHALER DESCRIPTION

The PuffHaler depends upon squeezing a pliable bottle to pop a polymeric pressure release valve and disperse a dose of microparticles. An air-filled bottle (660 cc), fitted with one or two valves in series, is manually squeezed to generate a pressure of ~14 kPa, which opens the valves. A volume of ~160 cc flows through the valves in less than 0.1 second and there is an accompanying audible pop and transient vibration. The first valve (Nike) must be stiffer than the second (Seaquist) if two valves are used. As the valves open, the compressed air disperses a bolus of dry microparticles into a detachable reservoir, which is fitted with a permeable mask. The detached, collapsible reservoir/mask containing the aerosol cloud is gently pressed on the face of the subject, who inhales the aerosol over the span of up to 30 seconds. The aerosol generator can be re-used hundreds of times, while the mask/reservoir is disposable and not re-used to treat different subjects in order to prevent disease transmission. Older cooperative subjects may inhale a single breath from the reservoir through a mouthpiece.

REPRESENTATIVE VACCINES AND PHARMACEUTICALS MICRONIZED BY CAN-BD

- **Vaccines:** live attenuated measles virus vaccine, influenza live virus vaccine, hepatitis B surface of antigen (HBsAg) vaccine
- **Oligonucleotides:** siRNA
- **Antibodies:** PRIMATIZED® anti-CD4, human IgG, anti-human lambda light chain
- **Enzymes:** α₁-antitrypsin, trypsinogen, lactate dehydrogenase, lysozyme, insulin, alkaline phosphatase
- **Sugar excipient stabilizers:** myo-inositol, trehalose, mannitol, sorbitol, lactose, sucrose
- **Antibiotics:** moxifloxacin hydrochloride, tobramycin sulfate, amoxicillin, doxycycline, cefazolin, ciprofloxacin hydrochloride, amikacin, capreomycin, rifampin
- **Other:** phytosterols, PEG, PVP, hydrolyzed gelatin, sodium chloride, DPPC, salbutamol
- **Components in formulations:** buffers (tricine, sodium or potassium phosphate, sodium acetate, sodium citrate), surfactants (palmitic acid, stearic acid, Tween 20, Tween 80, Pluronic F68), amino acids (arginine, alanine, histidine, leucine, methionine), and metal chelating agents (EDTA, DTPA)

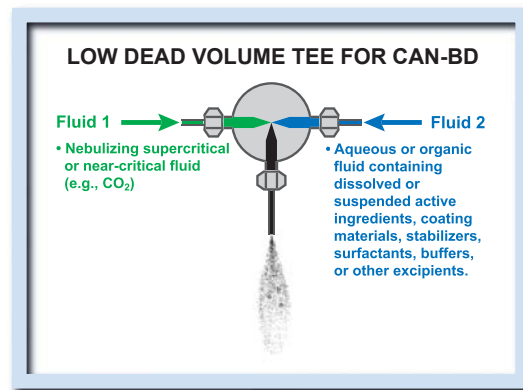

PRINCIPLES OF THE CAN-BD PROCESS

- In CAN-BD, dense CO₂ and a liquid aqueous solution or suspension are intimately mixed in a low volume mixing tee at room temperature and 83 bar.
- The mixture as an emulsion is rapidly expanded through a flow restrictor (ID of 75 to 380 μm) into a drying chamber at near atmospheric pressure to generate aerosols of microbubbles and microdroplets.
- Warm nitrogen gas is used to maintain the drying chamber at near ambient temperatures (usually below 60 °C) to dry the aerosols and generate dry powders. With myo-inositol based formulations, residual water can be < 0.5%.

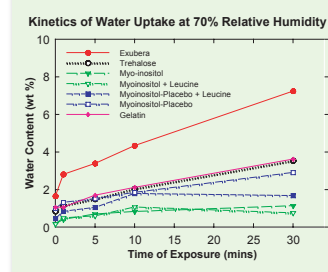

Formulation ID	Placeto	Fine Particle Fractions (% of loaded mass)		Glass Transition Temperature (Tg)		Moisture Content (%)
		< 4.5 μm	< 3.3 μm	Onset (°C)	Midpoint (°C)	
M50	Placeto	44 ± 2 (n=2)	19 ± 2 (n=2)	61 ± 2 (n=4)	65 ± 4 (n=4)	1.0 ± 0.3 (n=4)
	Active	50 ± 1 (n=2)	21 ± 2 (n=2)	53	61	...
M35man15	Placeto	43	19	60	61	0.9
	Active	51 ± 5 (n=2)	25 ± 4 (n=2)	48 ± 5 (n=4)	53 ± 4 (n=4)	0.8 ± 0.6 (n=4)
M25man25	Placeto	22	9	50	51	0.8
	Active	44	17	52	55	0.9
M15man35	Placeto	48	20	45	50	1.3
	Active	35	20	33	38	1.4
M25SS15	Placeto	43	19	50	41	0.8
	Active	44 ± 1 (n=3)	20 ± 2 (n=3)	54 ± 4 (n=3)	67 ± 2 (n=3)	0.8 ± 0.1 (n=3)
M50L2	Placeto	44 ± 1 (n=2)	27 ± 5 (n=2)	49 ± 1 (n=2)	57 ± 1 (n=2)	0.8 ± 0.2 (n=2)
	Active	48 ± 11 (n=2)	27 ± 5 (n=2)	49 ± 1 (n=2)	57 ± 1 (n=2)	0.8 ± 0.2 (n=2)

Myo-inositol based placebos are amorphous as determined by XRD. n = number of replicate powder lots tested. If not indicated, only one powder lot was tested. The error (±) is the standard deviation of the "n" replicate powder lots tested. With a little more aggressive drying during CAN-BD processing powders of myo-inositol based formulations with < 0.5% moisture content were produced.

Inhalable Dry Powder Measles Vaccine Formulation Development

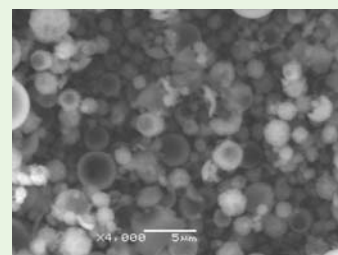

Scanning electron microscopy (SEM) image of particles of a myo-inositol based measles vaccine formulation formed at 50 °C from an aqueous solution containing 11% total dissolved solids.

Legend of Formulation IDs
 M50 = 50 g/L myo-inositol, other components*
 M35man15 = 35 g/L myo-inositol, 15 g/L mannitol, other components*
 M25man25 = 25 g/L myo-inositol, 25 g/L mannitol, other components*
 M15man35 = 15 g/L myo-inositol, 35 g/L mannitol, other components*
 M35S15 = 35 g/L myo-inositol, 15 g/L sorbitol, other components*
 M25S25 = 25 g/L myo-inositol, 25 g/L sorbitol, other components*
 M35S15 = 15 g/L myo-inositol, 35 g/L sorbitol, other components*
 M50L2 = 50 g/L myo-inositol, 2 g/L leucine, other components*
 M30G15 = 30 g/L myo-inositol, 15 g/L gelatin, other components*
 *Other components = 25 g/L gelatin (except for M30G15), 16 g/L arginine-HCl, 1 g/L alanine, 2.1 g/L histidine, 3.5 g/L lactalbumin hydrolysate, 3 g/L tricine, pH 6.5 - 7.0

Retention of Activity Through CAN-BD Processing

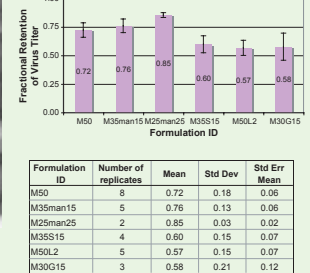

Formulation ID	Number of replicates	Mean	Std Dev	Std Err Mean
M50	8	0.72	0.18	0.06
M35man15	5	0.76	0.13	0.06
M25man25	2	0.85	0.03	0.02
M35S15	4	0.60	0.15	0.07
M50L2	5	0.57	0.15	0.07
M30G15	3	0.58	0.21	0.12

Retention of Activity After 7 Days at 37 °C

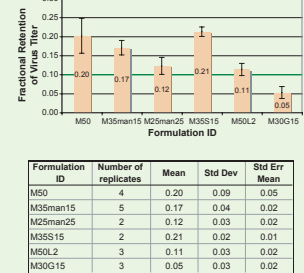

Formulation ID	Number of replicates	Mean	Std Dev	Std Err Mean
M50	4	0.20	0.09	0.05
M35man15	5	0.17	0.04	0.02
M25man25	2	0.12	0.03	0.02
M35S15	2	0.21	0.02	0.01
M50L2	3	0.11	0.03	0.02
M30G15	3	0.05	0.03	0.02

Activity of a myo-inositol based powder (M50)

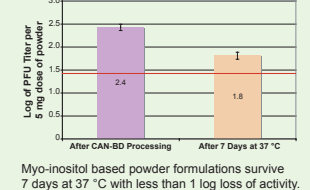

Myo-inositol based powder formulations survive 7 days at 37 °C with less than 1 log loss of activity.

Activity of a Trehalose Based Powder

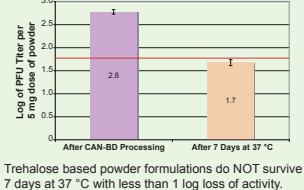

Trehalose based powder formulations do NOT survive 7 days at 37 °C with less than 1 log loss of activity.

The PuffHaler Active DPI Development



Plume of CAN-BD generated powder dispersed from the PuffHaler.

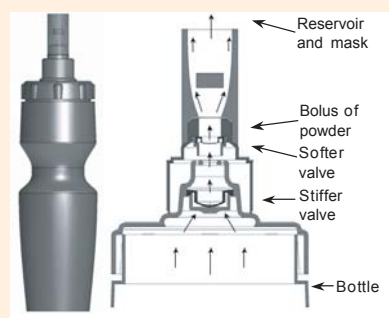

The PuffHaler active DPI, with valves and bottle aerosolizer (images at left), and detachable reservoir and mask with aerosolized dose being emitted (at right) upon gently squeezing the collapsible bag reservoir.

Peak Flow Rate Through the Pressure Relief Valve

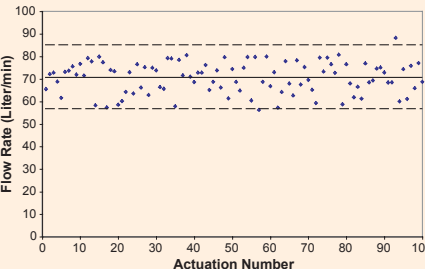

The PuffHaler shows good reproducibility over multiple actuations. After 100 tests, only one run was outside the range of +/- 20% of the mean flow rate and no noticeable decrease in performance was observed.

Comparison of Exubera and PuffHaler Performance

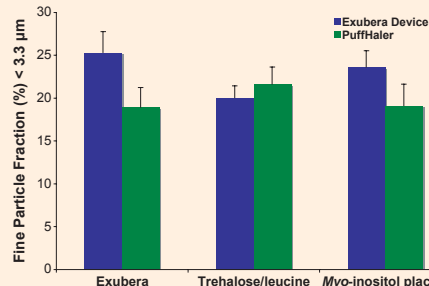

The PuffHaler has shown performance similar to Nektar/Pfizer's Exubera device when tested with three different powders, and measuring FPF.

Flow from PuffHaler

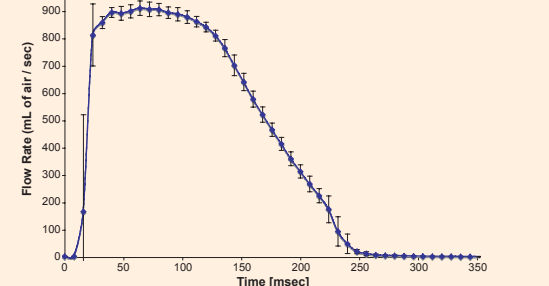

The flow profile out of the PuffHaler, and the dispersive energy it provides to powders, is consistent across runs. The above figure shows the average flow rate over time for 10 actuations.

CONCLUSIONS

- A stabilization, nebulization, and drying method (CAN-BD) has been presented that can manufacture dry powders of vaccines, oligonucleotides, proteins, enzymes, antibodies, and other drugs without unacceptable degradation.
- Antibodies, vaccines and enzymes retain activity during CAN-BD processing and long-term storage when appropriately buffered and stabilized with high purity sugars, surfactants, and/or other excipients.
- Drying requires only seconds at near-ambient conditions of temperature and pressure.
- Fluid ratios, pressures, and solute concentrations determine particle size (usually 1 - 5 μm) for optimal pulmonary delivery.

siRNA



Scanning electron microscopy (SEM) image of pure siRNA particles formed at 50 °C from a 10% aqueous solution.



Scanning electron microscopy (SEM) image of particles of siRNA in a myo-inositol based formulation formed at 50 °C from a 10% aqueous solution (50 g/L siRNA, 50 g/L myo-inositol).

REFERENCES

1. Sievers, R.E., Best, J.A. and Cape, S.P. (2006), "Human-Powered Dry Powder Inhaler", US Patent Application.
2. S.P. Sellers, *et al.* (2001), "Dry Powders of Stable Protein Formulations from Aqueous Solutions Prepared Using Supercritical CO₂-Assisted Aerosolization," *Journal of Pharmaceutical Sciences*, 90, 785-797.
3. R.E. Sievers and U. Karst, "Methods for fine particle formation," U.S. Patent 5,639,441; June 17, 1997.
4. R.E. Sievers and U. Karst, "Methods and apparatus for fine particle formation," European Patent 0677332B1; February 27, 2002.
5. R.E. Sievers, S.P. Sellers, and J.F. Carpenter, "Supercritical fluid-assisted nebulization and bubble drying," U.S. Patent 6,630,121; October 7, 2003.
6. J.A. Villa, *et al.* (2005), "Synthesis of Composite Microparticles with a Mixing Cross," *Aerosol Science and Technology*, 39, 473-484.
7. R.E. Sievers, *et al.* (2007), "Near-critical Fluid Micronization of Stabilized Vaccines, Antibiotics, and Anti-virals," *Journal of Supercritical Fluids* (in press).
8. H.M. Janssens, *et al.* (2003), "Extra-fine particles improve lung delivery of inhaled steroids in infants: a study in an upper airway model," *Chest*, 123, 2083-2088.
9. P. Albrecht, *et al.* (1981), "Role of Virus-Strain in Conventional and Enhanced Measles Plaque Neutralization Test," *Journal of Virological Methods*, Vol 3, No 5, pp 251-260.
10. J.V. Bennett *et al.* (2002), "Aerosolized measles and measles-rubella vaccines induce better measles antibody booster responses than injected vaccines: randomized trials in Mexican schoolchildren," *Bulletin of the World Health Organization*, 80, 806-812.
11. F.T. Cutts, *et al.* (1997), "Alternative routes of measles immunization: a review," *Biologicals*, 25, 323-338.
12. A.M. Henao-Restrepo and M. Papania, (2003), "Measles vaccination by aerosol," *Innovative Administration Systems for Vaccines*, Rockville, MD, December 18-19.
13. A.B. Sabin, *et al.* (1983), "Successful immunization of children with and without maternal antibody by aerosolized measles vaccine. I. Different results with undiluted human diploid cell and chick embryo fibroblast vaccine," *JAMA*, 249, 2651-2662.

• Additional references: www.AKTIV-DRY.com.

ACKNOWLEDGEMENTS



Funded in part by a Grant from the Foundation for the National Institutes of Health through the Grand Challenges in Global Health initiative. The authors gratefully acknowledge support from the Centers for Disease Control and Prevention (for help setting up the measles plaque assay), the University of Colorado Undergraduate Research Opportunities Program, and the Serum Institute of India (for the measles vaccine samples). The siRNA was provided by a collaborator. Technical assistance in conducting virus activity assays (Prof. Mark Hernandez, Lowry Lindsay, Karen Jones, Nicholas Wong, and Adam Bergfelder), device development (Ashley Butcher), and CAN-BD processing (David Krank, Nicolette Wolters), and powder analysis (Akiko Komura) is also acknowledged. Expert consulting was also provided by Prof. John Carpenter (formulation development) and Dr. Clyde Witham (device development).