

Quadrupole mass spectrometer system
QMG 422

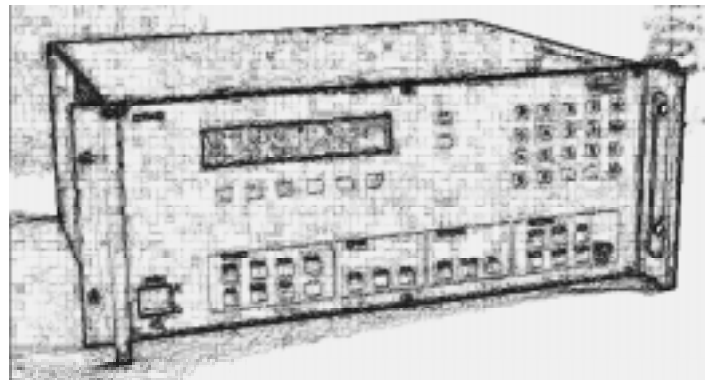
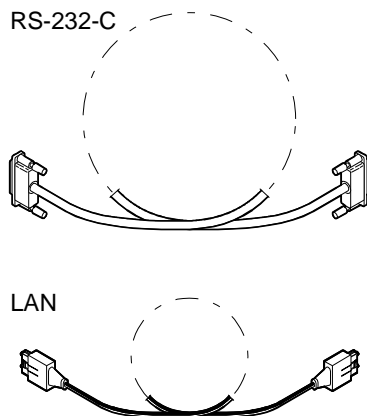
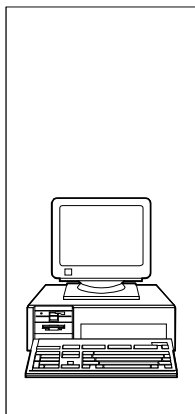

Table of contents

1 Important information	3
1.1 Explanation of symbols	3
1.2 Validity	3
1.3 Bibliography	3
2 Description	4
2.1 RS-232-C interface	4
2.2 LAN interface	4
3 Installation	4
4 Technical data	4
5 RS-232-C interface (ASCII)	5
5.1 Data transmission	5
5.1.1 Definitions	5
5.1.2 Syntax	6
5.1.3 Communication protocol (data link)	6
5.1.4 Influencing the measurement by changing a parameter	7
5.2 Manual / computer operation	7
5.3 Mnemonics	8
5.3.1 <i>channels</i> group	8
5.3.2 <i>general</i> group	8
5.3.3 <i>ion source</i> group	9
5.3.4 <i>operation</i> group	9
5.3.5 Group of measured data not defined by a channel	9
5.3.6 Group of measured data defined by a channel	10
5.4 Description	11
5.4.1 <i>channels</i> group	11
5.4.2 <i>general</i> group	17
5.4.3 <i>ion source</i> group	21
5.4.4 <i>operation</i> group	22
5.4.5 Measured data not defined in measurement channels	26
5.4.6 Measured data defined in measurement channels	27
6 RS-232-C interface (binary)	31
6.1 Data transmission	31
6.1.1 Definitions	31
6.1.2 Communication protocol (data link)	31
6.1.3 Influencing the measurement by changing a parameter	34
6.2 Manual / computer operation	34
6.3 Block transfer diagram	35
6.4 Block identification	36
6.4.1 <i>channels</i> group	36
6.4.2 <i>general</i> group	37
6.4.3 <i>ion source</i> group	37
6.4.4 <i>operation</i> group	38
6.4.5 Group of measured data not defined by a channel	38
6.4.6 Group of measured data defined by a channel	38
6.5 Description	39
6.5.1 <i>channels</i> group	39
6.5.2 <i>general</i> group	45
6.5.3 <i>ion source</i> group	51
6.5.4 <i>operation</i> group	52
6.5.5 Group of measured values not defined in measurement channels	56
6.5.6 Group of measured data defined in channels (cycle data)	60
7 LAN interface	70
7.1 ARCNET® network	70
7.1.1 Token Passing Protocol	70
7.1.2 Reconfiguring the network	70
7.2 Data transmission	70
7.3 PC interface	70
Appendix	71
A Program examples	71
B Modifications with respect to the QMG 421	76

1 Important information

1.1 Explanation of symbols



WARNING

Information on preventing extensive equipment and environmental damage.



Note

Information on correct handling or use. Disregard can lead to malfunctions or minor equipment damage.

400 This symbol is used for information that applies only to the 400 series.

125 This symbol is used for information that applies only to the 125 series.

1.2 Validity

This document applies to QMG 422 systems with QMS 422 quadrupole control unit and QMI 422 controllers.

It is based on the following firmware numbers:

DSP / PRG-NR	BG 509 732 -..
QMS / PRG-NR	BG 509 733 -..
CS 422 / PRG-NR	BG 509 734 -..

The firmware number can be found with *config* TEST or read out with the Balzers Quadstar™ 422 software. The letter (A...Z) at the end of the firmware number is the modification index indicating the status of the software. This document is valid for higher indexes, too, although some additional features of the software may not be described herein.

We reserve the right to make technical changes without prior notice.

1.3 Bibliography

- [1] Operating manual Quadrupole mass spectrometer QMG 422
BG 800 451 BE
- [2] Operating manual Network controller board OPA 200
SH-ARC BAL

Available at:

Balzers Instruments, FL 9496 Balzers, Fürstentum Liechtenstein

2 Description

2.1 RS-232-C interface

- Standard serial interface according to the RS 232 C standard. Allows various data transmission rates.

RS-232-C ASCII format

- Serial communication interface with ASCII-coded data format and simple communication protocol.

This interface format is very easy to use and is thus often used in combination with BASIC programs.

RS-232-C binary format

- Serial communication interface with binary-coded data format and communication protocol according to 'SECS-1' with higher transmission reliability.

This interface format is used for communication between the control unit and the QUADSTAR 422™ software. However, it can also be used for other purposes.

2.2 LAN interface

- Network-compatible serial interface for high transmission rates and long distances.

This is a fiber optics interface for an 'ARCNET® Local Area Network'. The optical transmission technology used for this interface keeps interference to a minimum.

3 Installation

Installation is described in the operating manual QMG 422 [1].

4 Technical data

Refer to the operating instructions for the QMG 422 [1] for technical data of the interface.

5 RS-232-C interface (ASCII)

5.1 Data transmission

The data transmission is bi-directional i.e. data and control commands can be transmitted in either direction.

5.1.1 Definitions

The following abbreviations are used:

Abbreviations and symbols

Symbols	Definition		Decimal	Hex
Computer	Computer or terminal			
QC 422	Quadrupole Controller QC 422			
[...]	Optional elements			
ASCII	American Standard Code for Information Interchange			
<ETX>	END OF TEXT	Reset the interface	3	03
<CR>	CARRIAGE RETURN	Go to the beginning of the line	13	0D
<LF>	LINE FEED	Advance by one line	10	0A
<SP>	SPACE	Leave a space	32	20
<NUL>	NULL	Pertains to a negligible value or a lack of information	0	00
<ENQ>	ENQUIRY	Request for data transmission	5	05
<ACK>	ACKNOWLEDGE	Positive report signal	6	06
<NAK>	NEGATIVE ACKNOWLEDGE	Negative report signal	21	15

Terms

"Transmit": Data transfer from the computer to the Quadrupole Controller
 "Receive": Data transfer from the Quadrupole Controller to the computer

Types of data

"Programming data"
 such as the parameter data commands transmitted from a computer to a Quadrupole Controller.

"Measured data"
 such as signals resulting from measurements which are transmitted to the computer for processing.

"Status data"
 information on the momentary operational status of the Quadrupole Controller output as the result of a specific enquiry.

Data formats

Mnemonics

An abbreviation consisting of three letters or two letters and a numeral. Capital or lower case letters (alpha characters) can be used.

Numeric

The whole number contains the numeric information. There are three ways to express the decimal part of the number:

Presentation with whole numbers

Corresponds to a style in which the decimal point at the end of a number is accepted, but not transmitted
 (1, 2, 3, ... 10, ... 20 etc.).

Floating point decimal

Its position depends on its place value in any particular instance. The decimal point should always be preceded by a numeral, even when this is a zero (0.1, ... 1.345, ... 1.0 etc.).

Exponential presentation

with fixed point part and fixed decimal point, the letter E and a two place exponent with sign digit (1.234E-12, etc.).

High order zeros

do not need to be entered. Reports never include them.

Sign digit

The '+' is not written for positive numbers.

Separator

The smallest unit is the character string. It is separated from the next block of data by a comma.

Delimiter

The coding for a legal final character is the ISO 7-bit code <CR> (carriage return). When a final character comes through, the Quadrupole Controller (the transmitter) goes from an active transmission state to an idle state.

5.1.2 Syntax

Arrows located between fields that point to the right indicate the sequence in which the transmission must be made. Arrows pointing to the left are feedback loops indicating the possibility of one or more repetitions of the field. Arrows pointing to the right that surround fields indicate that this field can be included as an option.

Record (data block)

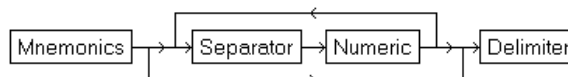

5.1.3 Communication protocol (data link)

Transmission format

The data transmission procedure is character-oriented, meaning that the message is transmitted to the control unit as programming data in ASCII strings. Each message is terminated with <CR> (end of message). <LF> may be transmitted, but it is ignored by the control unit. All other incoming characters are filed in an input buffer. The string is not evaluated until the 'end of message' signal comes through. The computer must wait for the feedback message (<ACK><CR> or <NAK><CR>) before transmitting another string.

Transmission protocol

Computer	Quadrupole Controller	Explanation
Programming data <CR> [<LF>]	→	Receives message with end character
←	<ACK> <CR> <LF>	Positive confirmation of message receipt

Receive format

The output of measured data, status data or parameters must first be initialized with the appropriate programming data (mnemonics). Afterwards, i.e. after the <ACK><CR><LF> message is received, the measured data, status data or the parameters can be called with <ENQ>. A repeated transmission of <ENQ> calls further ASCII strings. <CR> can be entered after <ENQ>, but it is not necessary. <ENQ> always affects the last initialization. The transmission of data does not need to be confirmed by the computer. The computer's input buffer must have a minimum capacity of 256 characters.

Receive protocol

Computer	Quadrupole Controller	Explanation
<ENQ> [<CR> [<LF>]]	→	Request for data transmission
←	measured data, status data or parameters <CR> <LF>	Data transmitted with end character
	:	
<ENQ> [<CR> [<LF>]]	→	Request for data transmission
←	measured data, status data or parameters <CR> <LF>	Data transmitted with end character
	:	

Error control

All strings are checked. If an error is detected, all the characters up to the next <CR> are ignored, and the negative confirmation <NAK> is output. The appropriate flag is set in the error word. Errors can be decoded when the error word is read.

Error recognition protocol

Computer	Quadrupole Controller	Explanation
Programming data <CR> [<LF>]	→ →	Receives message with end character
***** Transmission or ***** ***** programming error *****		
	← <NAK> <CR> <LF>	Negative confirmation of a message
Programming data <CR> [<LF>]	→ →	Receives string with end character
	← <ACK> <CR> <LF>	Positive confirmation of a message

5.1.4 Influencing the measurement by changing a parameter



WARNING

If, as it is entered, a parameter change affects an active measurement cycle, the measured data ring buffer is cleared and the cycle is repeated. In the same way changes to an *operation* parameter cause the measurement to be repeated.

5.2 Manual / computer operation

only with the CS 422 control unit:

The switchover — from the console or via the interface — from manual to computer operation can be made manually or via the computer. All entry possibilities have equal status i.e. the input control can switch operation to itself, thereby disabling other controls. Any attempt by the computer to address the QMS 421 in «CTRL» «MODE» «CS421» using mnemonics other than CMO,x is acknowledged with <NAK><CR>. This guarantees that the computer always receives an answer.



Note

In the appendix there are two program examples for measurements over the RS-232-C interface in ASCII format.

5.3 Mnemonics

5.3.1 channels group

Function	Parameter	Mnemonics	Page	Meaning
<i>select</i>	Measure-Ch	SMC	11	Selected measurement channel
	Parameter-Ch	SPC	11	Selected parameter channel
<i>detect</i>	TYPE	DTY	11	Signal source selection
	SEM	DSE	11	SEM high voltage for a channel
	AI-CH / PI-CH	DAI	11	Analog input or Pirani channel number
	PE-CTRL	DPC	11	Enable / disable the cold cathode measurement circuit
<i>mass</i>	MODE	MMO	12	Spectrum scan operation
	FIRST / MASS	MFM	12	First mass for a scan / mass number
	WIDTH	MWI	12	Width of a scan
	SPEED / DWELL	MSD	12	Measurement speed / measurement time
	RESOL	MRE	12	Resolution
	THRESH	MTH	13	Peak processor threshold
	AVERAGE	MAV	13	Number of values used for averaging
Steps	MST	13	Measurement channel resolution (points per mass)	
<i>amplif</i>	MODE	AMO	14	Measurement range switching mode
	RANGE	ARA	14	Electrometer range, display range
	RANGE-L	ARL	14	Narrowest measurement range for Auto Down
	GAIN	AGA	14	Post amplification factor
	FILTER	AFI	14	Analog filter setting
	OFFSET	AOF	15	Offset correction for the electrometer
	CALIB	ACA	15	Calibration factor for the measured value
	P-CAL	APC	15	"Break" factor for changing the measurement channel in multichannel operation
	CP-LEV	ACL	15	Response threshold for the ion counter preamplifier
	P-Time	APT	15	"Break" time for measurement channel switchover
<i>aux</i>	STATE	AST	15	Enable measurement channel
	COPY TO CH	ACO	15	Copy the parameter set to channel xx
<i>output</i>	AO-CH	OAC	16	Analog output channel number
	AO-MODE	OMO	16	Analog output mode
	MONITOR	OAM	16	Analog output monitor
	LOG-DEC	ODC	16	Logarithmic presentation at analog output
<i>trip</i>	TYPE	TTY	16	Type of switching function
	LEVEL-A	TLA	16	Switching function A / lower threshold for switching funct.
	LEVEL-B	TLB	16	Switching function B / upper threshold for switching funct.
	DO-A	TDA	16	Digital output bit number for switching function A
	DO-B	TDB	17	Digital output bit number for switching function B

5.3.2 general group

Function	Parameter	Mnemonics	Page	Meaning
<i>di/do</i>	DIG-IN	DIS	17	Digital input status
	DIG-OUT	DOC	17	Digital output control
<i>config SYSTEM</i>	QMA	SQA	17	Type of analyzer
	MASS-R	SMR	17	Type of mass range
	DETECT	SDT	17	Type of ion detector
	IS-TYP	SIT	18	Type of ion source
	OPTION	SOP	18	System expansion information
<i>config QMS-HW</i>	QMS-HW	QHW	18	Pc boards in the QMS 422
<i>config INIT</i>	RESET	IRE	19	Parameter set (standard / user)
<i>config CTRL</i>	MODE	CMO	19	Select type of input
	BAUD	CBR	19	Transmission speed for the RS 232 C interface
	NODE	CNA	19	Node address for the LAN interface
	SEM+FIL	CSF	19	SEM and filament supply
<i>config SIMUL</i>	SIMUL	TSI	19	Simulated test spectrum
<i>config TEST</i>	QMS	TQM	20	RAM test, EPROM test, program number
	DSP	TDS	20	RAM test, EPROM test, program number
<i>error</i>	ERROR	ERR	20	Error message from QC 421
	Warning	EWN	20	Warning from QC 421
	State-QMS	ESQ	21	Control unit status

5.3.3 ion source group

Function	Parameter	Mnemonics	Page	Meaning
<i>emiss</i>	EMISS	EMI	21	Emission current
	E-PROT	EPR	21	Max. filament current
<i>v1...v6</i>	V1 IONREF	V01	21	Ion source voltage 1
	V2 CATH	V02	21	Ion source voltage 2
	V3 FOCUS	V03	22	Ion source voltage 3
	V4 F-AXIS	V04	22	Ion source voltage 4
	V5 EXTRACT	V05	22	Ion source voltage 5
	V6 DEF-I	V06	22	Ion source voltage 6
<i>v7...</i>	V7	V07	22	Ion source voltage 7
	V8	V08	22	Ion source voltage 8
	V9 WEHNELT	V09	22	Ion source voltage 9

5.3.4 operation group

Function	Parameter	Mnemonics	Page	Meaning
<i>sem hv</i>	SEM-VOLTAGE	SHV	22	Common SEM high voltage
	Control	SEM	23	Enable / disable the SEM high voltage
<i>ion src</i>	MODE	ISM	23	Type of ion source operation
	TYPE	ITY	23	Type of ion source
	FILAM	IFI	23	Filament change
	FIL1	IS1	23	Ion source set number for Filament 1
	FIL2	IS2	23	Ion source set number for Filament 2
	Emi-Disp	IED	23	Enable / disable the emission current display
	COPY	ICS	24	Copy the ion source set
	D-TIME	IDT	24	Duration of degas process
	D-EMIS	IDE	24	Emission current for degas
	D-PROT	IDP	24	Maximum filament current for degas
CTRL	ISC	24	Enable / disable degas	
<i>cycle</i>	FUNCT	CFU	24	Measurement cycle operation
	MODE	CYM	24	Measurement cycle sequence
	CYCLES	CYS	24	Number of measurement cycles
	BEGIN	CBE	25	First channel in cycle
	END	CEN	25	Last channel in cycle
	TRIG	CTR	25	Measurement cycle control
	Run-Time	CWA	25	Scan time
	ADJ-TYP	CCF	25	Measurement cycle coarse / fine peak adjustment
<i>run / halt</i>	RUN / HALT	CRU	25	Start / Stop the measurement cycle
<i>filam</i>	Fila-Emi	FIE	25	Enable / disable the emission

5.3.5 Group of measured data not defined by a channel

Function	Parameter	Mnemonics	Page	Meaning
TOTAL	Pirani	TPI	26	Total pressure Pirani
	Penning	TPE	26	Total pressure cold cathode
ANALOG	A-Input	AIN	26	Analog input status
	A-Output	AOU	26	Analog output status
<i>trip STATUS</i>	T-State	TST	26	Switching function status
EMIS	EMI-CUR	ECU	27	Emission current display on the QME 125

5.3.6 Group of measured data defined by a channel

Function	Parameter	Mnemonics	Page	Meaning
MESSDATA	B-Counter	MB	27	Contents counter for measured data buffer
	M-Counter			Number of measured values for this type of data
	M-State			Measurement is running / has finished
	M-Data Type			Type of data
	B-Header	MBH	27	Measured data buffer header
	B-Data	MDB	27–30	Measured data buffer

5.4 Description

5.4.1 channels group

5.4.1.1 select function

Measure-Ch

Transmit: **SMC** [,xx] <CR>[<LF>]
 Receive: <ACK><CR><LF>
 Transmit: <ENQ>[<CR>[<LF>]]
 Receive: xx <CR><LF>

Meaning	Values x	Comments
selected measurement channel	0 ... 63	

Parameter-Ch

Transmit: **SPC** [,xx] <CR>[<LF>]
 Receive: <ACK><CR><LF>
 Transmit: <ENQ>[<CR>[<LF>]]
 Receive: xx <CR><LF>

Meaning	Values x	Comments
selected measurement channel	0 ... 63	

5.4.1.2 detect function

TYPE

Transmit: **DTY** [,x] <CR>[<LF>]
 Receive: <ACK><CR><LF>
 Transmit: <ENQ>[<CR>[<LF>]]
 Receive: x <CR><LF>

Meaning	Values x	Comments
Selects the signal source	0 = FARAD 1 = SEM 2 = ION-CNT 3 = EXTERN 4 = PIRANI 5 = PENNING 6 = A-INPUT	

SEM

Transmit: **DSE** [,xxxx] <CR>[<LF>]
 Receive: <ACK><CR><LF>
 Transmit: <ENQ>[<CR>[<LF>]]
 Receive: xxxx <CR><LF>

Meaning	Values x	Comments
SEM high voltage defined by the channel	0 (SEM-HV) 1 ... 3500 V	<i>sem hv</i> applies for SEM-HV

AI-CH / PI-CH

Transmit: **DAI** [,xx] <CR>[<LF>]
 Receive: <ACK><CR><LF>
 Transmit: <ENQ>[<CR>[<LF>]]
 Receive: xx <CR><LF>

Meaning	Values x	Comments
AI channel number / PI channel number	x = 0 ... 15 / x = 0 ... 1	according to «TYPE»

PE-CTRL

Transmit: **DPC** [,x] <CR>[<LF>]
 Receive: <ACK><CR><LF>
 Transmit: <ENQ>[<CR>[<LF>]]
 Receive: x <CR><LF>

Meaning	Values x	Comments
The cold cathode measurement circuit is enabled / disabled	0 = OFF 1 = ON	

5.4.1.3 mass function

MODE

Transmit: **MMO** [,x] <CR><LF>
 Receive: <ACK><CR><LF>
 Transmit: <ENQ><CR><LF>
 Receive: x <CR><LF>

Meaning	Values x	Comments
Scan mode	0 = SCAN-N 1 = SCAN-F 2 = STAIR 3 = SAMPLE 4 = PEAK-L 5 = PEAK-F	Standard scan Scan with FIR filter Scan of whole number masses Standard measurement of a single mass Peak processor level criterion Peak processor FIR filter criterion

FIRST / MASS

Transmit: **MFM** [,xxxx.xx] <CR><LF>
 Receive: <ACK><CR><LF>
 Transmit: <ENQ><CR><LF>
 Receive: xxxx.xx <CR><LF>

Meaning	Values x	Comments
First mass for a scan / mass number	0.00 ... 2047.99	Internally in steps of $1/64$ ($1/32$); dependent on the mass range and «SPEED»

WIDTH

Transmit: **MWI** [,sxxxx] <CR><LF>
 Receive: <ACK><CR><LF>
 Transmit: <ENQ><CR><LF>
 Receive: sxxxx <CR><LF>

Meaning	Values x	Comments
Width of the scan	-2047 ... +2047 (Default = 100)	Except for «SAMPLE»; limited by the measurement range; backwards if negative

SPEED / DWELL

Transmit: **MSD** [,xx] <CR><LF>
 Receive: <ACK><CR><LF>
 Transmit: <ENQ><CR><LF>
 Receive: xx <CR><LF>

Meaning	Values x	Comments
Measurement speed per amu (for «SCAN»)	0 = 0,5 ms 1 = 1 ms 2 = 2 ms 3 = 5 ms	
Measurement time (for «SAMPLE»)	4 = 10 ms 5 = 20 ms 6 = 50 ms 7 = 0.1 s 8 = 0.2 s 9 = 0.5 s 10 = 1 s 11 = 2 s 12 = 5 s 13 = 10 s 14 = 20 s 15 = 60 s	

RESOL

Transmit: **MRE** [,xxx] <CR><LF>
 Receive: <ACK><CR><LF>
 Transmit: <ENQ><CR><LF>
 Receive: xxx <CR><LF>

Meaning	Values x	Comments
Resolution 400	0 ... 255	0 = off (integral spectrum) 1 = narrowest peak width 255 = largest peak width
Resolution 125	0 ... 1	0 = integral spectrum) 1 = on (standard spectrum)

THRESH

Transmit: **MTH** [,x] <CR>[<LF>]
 Receive: <ACK><CR><LF>
 Transmit: <ENQ>[<CR>[<LF>]]
 Receive: x <CR><LF>

Meaning	Values x	Comments
Threshold for peak processor	0 ...7	Electrometer operation in Fix range 0 = 0.01 %F.S. 1 = 0.03 %F.S. 2 = 0.1 %F.S. 3 = 0.3 %F.S. 4 = 1 %F.S. 5 = 3 %F.S. 6 = 10 %F.S. 7 = 30 %F.S. referenced to RANGE Electrometer operation in Auto range 0 = 0.01 %F.S. 1 = 1E-14 A 2 = 1E-13 A 3 = 1E-12 A 4 = 1E-11 A 5 = 1E-10 A 6 = 1E-9 A 7 = 1E-8 A Ion counter operation 0 = 10 ⁰ cps 1 = 10 ¹ cps 2 = 10 ² cps 3 = 10 ³ cps 4 = 10 ⁴ cps 5 = 10 ⁵ cps 6 = 10 ⁶ cps 7 = 10 ⁷ cps

AVERAGE

Transmit: **MAV** [,xx] <CR>[<LF>]
 Receive: <ACK><CR><LF>
 Transmit: <ENQ>[<CR>[<LF>]]
 Receive: xx <CR><LF>

Meaning	Values x	Comments
Number of samples used for averaging	0 = 1 Values 1 = 2 Values 2 = 4 Values 3 = 8 Values 4 = 16 Values 5 = 32 Values 6 = 64 Values 7 = 128 Values 8 = 256 Values 9 = 512 Values 10 = 1024 Values	

Steps

Transmit: **MST** [,x] <CR>[<LF>]
 Receive: <ACK><CR><LF>
 Transmit: <ENQ>[<CR>[<LF>]]
 Receive: x <CR><LF>

Meaning	Values x	Comments
Measurement channel resolution for Fix range	0 = 1/4 u	SPEED: 0.5 ms/u, 1 ms/u MASS-R: all
	1 = 1/8 u	
	2 = 1/16 u	
	0 = 1/8 u	SPEED: 2 ms/u, 5 ms/u MASS-R: all
	1 = 1/16 u	
	2 = 1/32 u	
0 = 1/16 u	SPEED: from 10 ms/u MASS-R: to 1024	
1 = 1/32 u		
2 = 1/64 u		
0 = 1/8 u	SPEED: from 10 ms/u MASS-R: 2048	
1 = 1/16 u		
2 = 1/32 u		

Measurement channel resolution for Auto range	0 = —	SPEED: 0.5 ms/u ... 5 ms/u
	1 = —	MASS-R: all
	2 = —	
	0 = $\frac{1}{4}$ u	SPEED: 10 ms/u, 20 ms/u
	1 = $\frac{1}{8}$ u	MASS-R: all
	2 = $\frac{1}{16}$ u	
	0 = $\frac{1}{8}$ u	SPEED: 50 ms/u, 100 ms/u
	1 = $\frac{1}{16}$ u	MASS-R: all
	2 = $\frac{1}{32}$ u	
	0 = $\frac{1}{16}$ u	SPEED: 200 ms/u ... 60 s/u
	1 = $\frac{1}{32}$ u	MASS-R: to 1024
	2 = $\frac{1}{64}$ u	
	0 = $\frac{1}{8}$ u	SPEED: 200 ms/u ... 60 s/u
	1 = $\frac{1}{16}$ u	MASS-R: 2048
	2 = $\frac{1}{32}$ u	

5.4.1.4 *amplif* function

MODE

Transmit: **AMO** [,x] <CR><LF>
 Receive: <ACK><CR><LF>
 Transmit: <ENQ><CR><LF>]]
 Receive: x <CR><LF>

Meaning	Values x	Comments
Measurement range switchover mode	0 = FIX 1 = AUTO-D 2 = AUTO	

RANGE

Transmit: **ARA** [,sxx] <CR><LF>
 Receive: <ACK><CR><LF>
 Transmit: <ENQ><CR><LF>]]
 Receive: sxx <CR><LF>

Meaning	Values x	Comments
Electrometer range in Fix range	E-12 ... E-5	Measurement range
Electrometer range in Auto range	E-12 ... E-5	Output display range
Ion counter operation	E-1 ... E+8	Output display range

RANGE-L

Transmit: **ARL** [,sxx] <CR><LF>
 Receive: <ACK><CR><LF>
 Transmit: <ENQ><CR><LF>]]
 Receive: sxx <CR><LF>

Meaning	Values x	Comments
Lowest electrometer range for Auto-D	E-12 ... E-5	For «FARAD» or «SEM»

GAIN

Transmit: **AGA** [,x] <CR><LF>
 Receive: <ACK><CR><LF>
 Transmit: <ENQ><CR><LF>]]
 Receive: x <CR><LF>

Meaning	Values x	Comments
Post gain factor	0 = x-10 1 = x-1 2 = x1 3 = x10	Only for <i>detect</i> «TYPE» : «EXTERN»

FILTER

Transmit: **AFI** [,x] <CR><LF>
 Receive: <ACK><CR><LF>
 Transmit: <ENQ><CR><LF>]]
 Receive: x <CR><LF>

Meaning	Values x	Comments
Analog filter setting	0 = AUTO 1 = 18 µs 2 = 85 µs 3 = 400 µs 4 = 1.7 ms 5 = 8 ms 6 = 40 ms 7 = 180 ms 8 = 800 ms	Auto = appropriate for «SPEED »

OFFSET

Transmit: **AOF** [,0] <CR><LF>
 Receive: <ACK><CR><LF>
 Transmit: <ENQ><CR><LF>
 Receive: sxxxx,sxxxx,....,sxxxx
 <CR><LF>

Meaning	Values x	Comments
Offset correction for the electrometer	(8x) -32768 ... +32676	Offset values for range E-5, E-6, ..., E-12 $I_{\text{offset}} = \text{value } x / 32000 \times \text{range}$ Transmission of value 0 results in Clear of all offset values

CALIB

Transmit: **ACA** [,sx.xxEsxx] <CR><LF>
 Receive: <ACK><CR><LF>
 Transmit: <ENQ><CR><LF>
 Receive: sx.xxEsxx <CR><LF>

Meaning	Values x	Comments
Calibration factor for measured value	$\pm(1.00 \text{ E-10} \dots \dots 9.99 \text{ E+10})$	

P-CAL

Transmit: **APC** [,x.x] <CR><LF>
 Receive: <ACK><CR><LF>
 Transmit: <ENQ><CR><LF>
 Receive: x.x <CR><LF>

Meaning	Values x	Comments
Measurement pause for changing the channel in multichannel operation	0.0 ... 9.9	

CP-LEV

Transmit: **ACL** [,x.xx] <CR><LF>
 Receive: <ACK><CR><LF>
 Transmit: <ENQ><CR><LF>
 Receive: x.xx <CR><LF>

Meaning	Values x	Comments
Measurement pause for changing the channel in multichannel operation	0.10 ... 1.00 V	In steps of 0.02 V

P-Time (channel change)

Transmit: **APT** <CR><LF>
 Receive: <ACK><CR><LF>
 Transmit: <ENQ><CR><LF>
 Receive: xxxxx <CR><LF>

Meaning	Values x	Comments
Post gain factor for chopper lock-in amplifier	0 ... 65,535	Resolution = Pause time for changing channels 1 ms

5.4.1.5 aux function**STATE**

Transmit: **AST** [,x] <CR><LF>
 Receive: <ACK><CR><LF>
 Transmit: <ENQ><CR><LF>
 Receive: x <CR><LF>

Meaning	Values x	Comments
Measurement channel enable	0 = ENABLE 1 = SKIP	The channel is enabled The channel is skipped

COPY TO CH

Transmit: **ACO** [,x,xx[,yy]] <CR><LF>
 Receive: <ACK><CR><LF>
 Transmit: <ENQ><CR><LF>
 Receive: 0,0,0 <CR><LF>

Meaning	Values x, y	Comments
Copy the parameter set to channel yy	x = 0 ... 2 0 = to all 1 = to one 2 = swap xx = 0 ... 63 yy = 0 ... 63	Copy from channel xx to all channels Copy from channel xx to channel yy Swap channel xx with yy

5.4.1.6 output function

AO-CH

Transmit: **OAC** [,xx] <CR>[<LF>]
 Receive: <ACK><CR><LF>
 Transmit: <ENQ>[<CR>[<LF>]]
 Receive: xx <CR><LF>

Meaning	Values x	Comments
Analog output channel number	0 ... 12	0 = no channel

AO-MODE

Transmit: **OMO** [,x] <CR>[<LF>]
 Receive: <ACK><CR><LF>
 Transmit: <ENQ>[<CR>[<LF>]]
 Receive: x <CR><LF>

Meaning	Values x	Comments
Analog output mode for AO	0 = linear 1 = logarithmic	

MONITOR

Transmit: **OAM** [,x] <CR>[<LF>]
 Receive: <ACK><CR><LF>
 Transmit: <ENQ>[<CR>[<LF>]]
 Receive: x <CR><LF>

Meaning	Values x	Comments
Analog output mode for mon	0 = linear 1 = logarithmic 2 = RNG code	

LOG-DEC

Transmit: **ODC** [,x] <CR>[<LF>]
 Receive: <ACK><CR><LF>
 Transmit: <ENQ>[<CR>[<LF>]]
 Receive: x <CR><LF>

Meaning	Values x	Comments
Logarithmic presentation	0 = 3 DEC 1 = 10 DEC	Only for ion counting operation

5.4.1.7 trip function

TYPE

Transmit: **TTY** [,x] <CR>[<LF>]
 Receive: <ACK><CR><LF>
 Transmit: <ENQ>[<CR>[<LF>]]
 Receive: x <CR><LF>

Meaning	Values x	Comments
Type of switching function	0 = OFF 1 = ABS 2 = HYST	Switching function disabled Switching function without hysteresis Switching function with hysteresis

LEVEL-A

Transmit: **TLA** [,x.xxEsxx] <CR>[<LF>]
 Receive: <ACK><CR><LF>
 Transmit: <ENQ>[<CR>[<LF>]]
 Receive: x.xxEsxx <CR><LF>

Meaning	Values x	Comments
Switching function A / lower threshold for the switching function	1.00 E-24 9.99 E+24	

LEVEL-B

Transmit: **TLB** [,x.xxEsxx] <CR>[<LF>]
 Receive: <ACK><CR><LF>
 Transmit: <ENQ>[<CR>[<LF>]]
 Receive: x.xxEsxx <CR><LF>

Meaning	Values x	Comments
Switching function B / upper threshold for the switching function	1.00 E-24 9.99 E+24	

DO-A

Transmit: **TDA** [,xx] <CR>[<LF>]
 Receive: <ACK><CR><LF>
 Transmit: <ENQ>[<CR>[<LF>]]
 Receive: xx <CR><LF>

Meaning	Values x	Comments
Digital output bit number for switching function A	0 ... 95 99	off

DO-B

Transmit: **TDB** [,xx] <CR><LF>
 Receive: <ACK><CR><LF>
 Transmit: <ENQ><CR><LF>]]
 Receive: xx <CR><LF>

Meaning	Values x	Comments
Digital output bit number for switching function B	0 ... 95 99	off

5.4.2 general group

5.4.2.1 di/do function

DIG-IN

Transmit: **DIS** [,xx] <CR><LF>
 Receive: <ACK><CR><LF>
 Transmit: <ENQ><CR><LF>]]
 Receive: xx,x <CR><LF>

Meaning	Values x	Comments
Digital input statuses	xx = 0 ...63 x = 0 ... 1 0 = Low 1 = High	Bit number Read bit status

DIG-OUT

Transmit: **DOC** [,xx[,x]] <CR><LF>
 Receive: <ACK><CR><LF>
 Transmit: <ENQ><CR><LF>]]
 Receive: xx,x <CR><LF>

Meaning	Values x	Comments
Digital output control	xx = 0 ...95 99 x = 0 ... 1 0 = Clear 1 = Set	Bit number All bits Bit manipulation

5.4.2.2 config SYSTEM function

QMA

Transmit: **SQA** [,x] <CR><LF>
 Receive: <ACK><CR><LF>
 Transmit: <ENQ><CR><LF>]]
 Receive: x <CR><LF>

Meaning	Values x	Comments
Defines the type of analyzer	0 = QMA 125 1 = QMA 400 2 = QMA 410 3 = QMA 430 4 = QMA 200	only for information

MASS-R

Transmit: **SMR** [,x] <CR><LF>
 Receive: <ACK><CR><LF>
 Transmit: <ENQ><CR><LF>]]
 Receive: x <CR><LF>

Meaning	Values x	Comments
Defines the mass range	0 = 100 1 = 200 2 = 128 3 = 512 4 = 1024 5 = 2048 6 = 340 7 = 300	QME 125-1 QMA 125 QME 125-2 QMA 125 QMH 400-1 QMA 410 QMH 400-5 QMA 400 QMH 410-1 QMA 400 QMH 410-2 QMA 400 QMH 410-3 QMA 410 QMH 400-5 QMA 430

DETECT

Transmit: **SDT** [,x] <CR><LF>
 Receive: <ACK><CR><LF>
 Transmit: <ENQ><CR><LF>]]
 Receive: x <CR><LF>

Meaning	Values x	Comments
<div style="border: 1px solid black; display: inline-block; padding: 2px;">400</div> Defines the type of ion detection	0 = FARAD 1 = SEM 2 = CD-SEM 3 = H-SEM	Faraday 0° SEM 90° SEM — conversion dynode floating SEM

5.4.2.4 config INIT function

RESET

Transmit: **IRE** ,x <CR><LF>
 Receive: <ACK><CR><LF>
 Transmit: <ENQ><CR><LF>]]
 Receive: 0 <CR><LF>

Meaning	Values x	Comments
Set of parameters for the ion source and the measurement channels	0 = NO 1 = FACTORY	no action Default parameters

5.4.2.5 config CTRL function

MODE

Transmit: **CMO** [,x] <CR><LF>
 Receive: <ACK><CR><LF>
 Transmit: <ENQ><CR><LF>]]
 Receive: x <CR><LF>

Meaning	Values x	Comments
Type of input	0 = CS 422 1 = ASCII 2 = BIN 3 = MODEM 4 = LAN	Console keyboard (QMS 422) RS 232 C with ASCII format RS 232 C with binary format RS 232 C with binary format Field bus interface format

BAUD

Transmit: **CBR** [,x] <CR><LF>
 Receive: <ACK><CR><LF>
 Transmit: <ENQ><CR><LF>]]
 Receive: x <CR><LF>

Meaning	Values x	Comments
Transmission speed for the serial interface	0 = 300 bit/s 1 = 1200 bit/s 2 = 2400 bit/s 3 = 4800 bit/s 4 = 9600 bit/s 5 = 19200 bit/s	

NODE

Transmit: **CNA** [,xxx] <CR><LF>
 Receive: <ACK><CR><LF>
 Transmit: <ENQ><CR><LF>]]
 Receive: xxx <CR><LF>

Meaning	Values x	Comments
Node address for the field bus interface	1 ... 255 (Default = 83)	53H

SEM+FIL

Transmit: **CSF** [,x] <CR><LF>
 Receive: <ACK><CR><LF>
 Transmit: <ENQ><CR><LF>]]
 Receive: x <CR><LF>

Meaning	Values x	Comments
Defines the SEM and filament supply	0 = INTERN 1 = EXTERN 2 = EXT-PROT	

5.4.2.6 config SIMUL function

SIMUL

Transmit: **TSI** [,x] <CR><LF>
 Receive: <ACK><CR><LF>
 Transmit: <ENQ><CR><LF>]]
 Receive: x <CR><LF>

Meaning	Values x	Comments
Spectrum simulation for testing purposes	0 = OFF 1 = INTERN 2 = EXTERN	No simulation Internal simulation External simulation

5.4.2.7 config TEST function

 **Note**

Depending on the test, two to three seconds can elapse between transmission and receipt.

QMS

Transmit: **TQM** ,x <CR>[<LF>]
 Receive: <ACK><CR><LF>
 Transmit: <ENQ>[<CR>[<LF>]]
 Receive: x[,yyyyyyyyyy] <CR><LF>

Meaning	Values x, y	Comments
Control unit test routine	x = 0 ... 3 0 = RAM-T 1 = EPROM-T 2 = PRG-NR 3 = no test yyyyyyyyyy	Checksum for test 1 or Program number for test 2

DSP

Transmit: **TDS** ,x <CR>[<LF>]
 Receive: <ACK><CR><LF>
 Transmit: <ENQ>[<CR>[<LF>]]
 Receive: x[,yyyyyyyyyy] <CR><LF>

Meaning	Values x, y	Comments
Digital signal processor test	x = 0 ... 3 0 = RAM-T 1 = EPROM-T 2 = PRG-NR 3 = no test yyyyyyyyyy	Checksum for test 1 or Program number for test 2

5.4.2.8 error function

ERROR

Transmit: **ERR** <CR>[<LF>]
 Receive: <ACK><CR><LF>
 Transmit: <ENQ>[<CR>[<LF>]]
 Receive: xxxxxxxxxx <CR><LF>

Meaning	Values x	Comments																																																																
Error messages (are cleared when a response to a query is transmitted)	xxxxxxxx = 0 ... $2^{32}-1$	<table border="0"> <tr> <td>Bit</td> <td>Error</td> <td>Bit</td> <td>Error</td> </tr> <tr> <td>0:</td> <td>No. 17</td> <td>16:</td> <td>No. 33</td> </tr> <tr> <td>1:</td> <td>No. 18</td> <td>17:</td> <td>No. 34</td> </tr> <tr> <td>2:</td> <td>No. 19</td> <td>18:</td> <td>No. 35</td> </tr> <tr> <td>3:</td> <td>No. 20</td> <td>19:</td> <td>No. 36</td> </tr> <tr> <td>4:</td> <td>No. 21</td> <td>20:</td> <td>No. 37</td> </tr> <tr> <td>5:</td> <td>No. 22</td> <td>21:</td> <td>No. 38</td> </tr> <tr> <td>6:</td> <td>No. 23</td> <td>22:</td> <td>No. 39</td> </tr> <tr> <td>7:</td> <td>No. 24</td> <td>23:</td> <td>No. 40</td> </tr> <tr> <td>8:</td> <td>No. 25</td> <td>24:</td> <td>No. 41</td> </tr> <tr> <td>9:</td> <td>No. 26</td> <td>25:</td> <td>No. 42</td> </tr> <tr> <td>10:</td> <td>No. 27</td> <td>26:</td> <td>No. 43</td> </tr> <tr> <td>11:</td> <td>No. 28</td> <td>27:</td> <td>No. 44</td> </tr> <tr> <td>12:</td> <td>No. 29</td> <td>28:</td> <td>No. 45</td> </tr> <tr> <td></td> <td></td> <td>29:</td> <td>No. 46</td> </tr> <tr> <td></td> <td></td> <td>30:</td> <td>No. 47</td> </tr> </table>	Bit	Error	Bit	Error	0:	No. 17	16:	No. 33	1:	No. 18	17:	No. 34	2:	No. 19	18:	No. 35	3:	No. 20	19:	No. 36	4:	No. 21	20:	No. 37	5:	No. 22	21:	No. 38	6:	No. 23	22:	No. 39	7:	No. 24	23:	No. 40	8:	No. 25	24:	No. 41	9:	No. 26	25:	No. 42	10:	No. 27	26:	No. 43	11:	No. 28	27:	No. 44	12:	No. 29	28:	No. 45			29:	No. 46			30:	No. 47
Bit	Error	Bit	Error																																																															
0:	No. 17	16:	No. 33																																																															
1:	No. 18	17:	No. 34																																																															
2:	No. 19	18:	No. 35																																																															
3:	No. 20	19:	No. 36																																																															
4:	No. 21	20:	No. 37																																																															
5:	No. 22	21:	No. 38																																																															
6:	No. 23	22:	No. 39																																																															
7:	No. 24	23:	No. 40																																																															
8:	No. 25	24:	No. 41																																																															
9:	No. 26	25:	No. 42																																																															
10:	No. 27	26:	No. 43																																																															
11:	No. 28	27:	No. 44																																																															
12:	No. 29	28:	No. 45																																																															
		29:	No. 46																																																															
		30:	No. 47																																																															

Warning

Transmit: **EWN** <CR>[<LF>]
 Receive: <ACK><CR><LF>
 Transmit: <ENQ>[<CR>[<LF>]]
 Receive: xxxxx <CR><LF>

Bedeutung	Werte x	Bemerkungen														
Warnings (are cleared when a response to a query is transmitted)	xxxxx = 0 ... $2^{16}-1$	<table border="0"> <tr> <td>Bit</td> <td>Warning</td> </tr> <tr> <td>0:</td> <td>No. 17</td> </tr> <tr> <td>1:</td> <td>No. 18</td> </tr> <tr> <td>2:</td> <td>No. 19</td> </tr> <tr> <td>3:</td> <td>No. 20</td> </tr> <tr> <td>4:</td> <td>No. 21</td> </tr> <tr> <td>5:</td> <td>No. 22</td> </tr> </table>	Bit	Warning	0:	No. 17	1:	No. 18	2:	No. 19	3:	No. 20	4:	No. 21	5:	No. 22
Bit	Warning															
0:	No. 17															
1:	No. 18															
2:	No. 19															
3:	No. 20															
4:	No. 21															
5:	No. 22															

State-QMS

Transmit: **ESQ** <CR>[<LF>]
 Receive: <ACK><CR><LF>
 Transmit: <ENQ>[<CR>[<LF>]]
 Receive: xxxxx,xxx <CR><LF>

Meaning	Values x	Comments
Control unit status	xxxxx = 0 ... 2 ¹⁶ -1	Bit Status 0 / 1 0: Cycle halt / run 1: Mono / Multi 2: Emission off / on 3: SEM supply off / on 4: Waiting for external trigger 5: Settling halt / run 6: I-Undergr. halt / run 7: Electrometer value / Emission current display 8: Degas off / on 9: Adjust off / on 10: Adjust run 11: 12: 13: 14: Ring buffer empty 15: Ring buffer overflow
 State of the emission	xxx = 0 ... 255	Bit 0...7 = QMU 0...7 0 = Emission okay 1 = Emission not okay

 **Note**
 The status 'Ringbuffer overflow' (Bit 15) is not cancelled until the next cycle is started (»Run«).

5.4.3 ion source group

5.4.3.1 emiss function

EMISS

Transmit: **EMI** [,x.xx] <CR>[<LF>]
 Receive: <ACK><CR><LF>
 Transmit: <ENQ>[<CR>[<LF>]]
 Receive: x.xx <CR><LF>

Meaning	Values x	Comments
 Emission current	0.00 ... 2.00 mA	

E-PROT

Transmit: **EPR** [,x.xx] <CR>[<LF>]
 Receive: <ACK><CR><LF>
 Transmit: <ENQ>[<CR>[<LF>]]
 Receive: x.xx <CR><LF>

Meaning	Values x	Comments
 Maximum filament current	0.00 ... 5.00 A	

5.4.3.2 v1...v6 and v7... functions

V1

Transmit: **V01** [,xxx] <CR>[<LF>]
 Receive: <ACK><CR><LF>
 Transmit: <ENQ>[<CR>[<LF>]]
 Receive: xxx <CR><LF>

Meaning	Values x	Comments
 Voltage 1: IONREF	0 ... 150 V	In steps of 1 V

V2

Transmit: **V02** [,xxx.x] <CR>[<LF>]
 Receive: <ACK><CR><LF>
 Transmit: <ENQ>[<CR>[<LF>]]
 Receive: xxx.x <CR><LF>

Meaning	Values x	Comments
 Voltage 2: CATH	0.0 ... 125.0 V	In steps of 0.5 V

V3

Transmit: **V03** [,sxx.xx] <CR><LF>
 Receive: <ACK><CR><LF>
 Transmit: <ENQ><CR><LF>
 Receive: sxx.xx <CR><LF>

Meaning	Values x	Comments
400 Voltage 3: FOCUS	-30.00 +30.00 V	In steps of 0.25 V

V4

Transmit: **V04** [,xx.xx] <CR><LF>
 Receive: <ACK><CR><LF>
 Transmit: <ENQ><CR><LF>
 Receive: xx.xx <CR><LF>

Meaning	Values x	Comments
400 Voltage 4: F-AXIS	0.00 ... 60.00 V	In steps of 0.25 V

V5

Transmit: **V05** [,xxx] <CR><LF>
 Receive: <ACK><CR><LF>
 Transmit: <ENQ><CR><LF>
 Receive: xxx <CR><LF>

Meaning	Values x	Comments
400 Voltage 5: EXTRACT	0 ... 450 V	In steps of 2 V

V6

Transmit: **V06** [,xxx] <CR><LF>
 Receive: <ACK><CR><LF>
 Transmit: <ENQ><CR><LF>
 Receive: xxx <CR><LF>

Meaning	Values x	Comments
400 Voltage 6: DEF-I	0 ... 450 V	In steps of 2 V

V7

Transmit: **V07** [,xxx] <CR><LF>
 Receive: <ACK><CR><LF>
 Transmit: <ENQ><CR><LF>
 Receive: xxx <CR><LF>

Meaning	Values x	Comments
400 Voltage 7:	0 .. 250 V	In steps of 1 V

V8

Transmit: **V08** [,sxxx] <CR><LF>
 Receive: <ACK><CR><LF>
 Transmit: <ENQ><CR><LF>
 Receive: sxxx <CR><LF>

Meaning	Values x	Comments
400 Voltage 8:	-125 ... +125 V	In steps of 1 V

V9

Transmit: **V09** [,xx.xx] <CR><LF>
 Receive: <ACK><CR><LF>
 Transmit: <ENQ><CR><LF>
 Receive: xx.xx <CR><LF>

Meaning	Values x	Comments
400 Voltage 9: WEHNELT	0.00 ... 60.00 V	In steps of 0.25 V

5.4.4 operation group

5.4.4.1 sem hv and sem functions

SEM-VOLTAGE

Transmit: **SHV** [,xxxx] <CR><LF>
 Receive: <ACK><CR><LF>
 Transmit: <ENQ><CR><LF>
 Receive: xxxx <CR><LF>

Meaning	Values x	Comments
Defined common SEM high voltage	0 ... 3500 V	SEM high voltage not defined in a measurement channel

Control

Transmit: **SEM** [,x] <CR>[<LF>]
 Receive: <ACK><CR><LF>
 Transmit: <ENQ>[<CR>[<LF>]]
 Receive: x <CR><LF>

Meaning	Values x	Comments
Define SEM high voltage status on / off	0 = OFF 1 = ON	with «FARAD» = off

5.4.4.2 ion src function

MODE

Transmit: **ISM** <CR>[<LF>]
 Receive: <ACK><CR><LF>
 Transmit: <ENQ>[<CR>[<LF>]]
 Receive: x <CR><LF>

Meaning	Values x	Comments
Defines the type of ion source operation	0 = NORMAL 1 = DEGAS	Emission

TYPE

Transmit: **ITY** [,x] <CR>[<LF>]
 Receive: <ACK><CR><LF>
 Transmit: <ENQ>[<CR>[<LF>]]
 Receive: x <CR><LF>

Meaning	Values x	Comments
400 Defines the type of ion source	0 = according to configuration 1 = SPEC+ 2 = SPEC-	

FILAM

Transmit: **IFI** [,x] <CR>[<LF>]
 Receive: <ACK><CR><LF>
 Transmit: <ENQ>[<CR>[<LF>]]
 Receive: x <CR><LF>

Meaning	Values x	Comments
400 Filament selection	x = 0 ... 2 0 = 1 1 = 2 2 = 1+2	Filament 1 with «FIL1-SET» Filament 2 with «FIL2-SET» If Filament 1 fails, switchover to Filament 2 with filament set change
125 Filament selection	x = 0 ... 1 0 = 1 1 = 2	Filament 1 Filament 2

FIL1

Transmit: **IS1** [,x] <CR>[<LF>]
 Receive: <ACK><CR><LF>
 Transmit: <ENQ>[<CR>[<LF>]]
 Receive: x <CR><LF>

Meaning	Values x	Comments
400 Ion source set number for Filament 1	0 ... 3	

FIL2

Transmit: **IS2** [,x] <CR>[<LF>]
 Receive: <ACK><CR><LF>
 Transmit: <ENQ>[<CR>[<LF>]]
 Receive: x <CR><LF>

Meaning	Values x	Comments
400 Ion source set number for Filament 2	0 ... 3	

Emi-Disp

Transmit: **IED** [,x] <CR>[<LF>]
 Receive: <ACK><CR><LF>
 Transmit: <ENQ>[<CR>[<LF>]]
 Receive: x <CR><LF>

Meaning	Values x	Comments
125 Emission current display	0 = OFF 1 = ON	Emission current display off (standard operation) Emission current display on

COPY

Transmit: **ICS** [,x,y] <CR>[<LF>]
 Receive: <ACK><CR><LF>
 Transmit: <ENQ>[<CR>[<LF>]]
 Receive: x,y <CR><LF>

Meaning	Values x, y	Comments
400 Copy the ion source set	x = 0 ... 3 y = 0 ... 3	Copy from set x to set y

D-TIME

Transmit: **IDT** [,xx] <CR>[<LF>]
 Receive: <ACK><CR><LF>
 Transmit: <ENQ>[<CR>[<LF>]]
 Receive: xx <CR><LF>

Meaning	Values x	Comments
Duration of Degas	0 = MANUAL 1 ... 99 min	Continue Degas until stop command is entered manually

D-EMIS

Transmit: **IDE** [,xx.x] <CR>[<LF>]
 Receive: <ACK><CR><LF>
 Transmit: <ENQ>[<CR>[<LF>]]
 Receive: xx.x <CR><LF>

Meaning	Values x	Comments
400 Emission current for Degas	0.0 ... 20.0 mA	

D-PROT

Transmit: **IDP** [,x.xx] <CR>[<LF>]
 Receive: <ACK><CR><LF>
 Transmit: <ENQ>[<CR>[<LF>]]
 Receive: x.xx <CR><LF>

Meaning	Values x	Comments
400 Maximum filament current for Degas	0.00 ... 5.00 A	

CTRL

Transmit: **ISC** [,x] <CR>[<LF>]
 Receive: <ACK><CR><LF>
 Transmit: <ENQ>[<CR>[<LF>]]
 Receive: x <CR><LF>

Meaning	Values x	Comments
Turn Degas on / off	0 = STOP 1 = START / RUN	

5.4.4.3 cycle function

FUNCT

Transmit: **CFU** [,x] <CR>[<LF>]
 Receive: <ACK><CR><LF>
 Transmit: <ENQ>[<CR>[<LF>]]
 Receive: x <CR><LF>

Meaning	Values x	Comments
Defines the type of measurement cycle	0 = CYCLE 1 = ADJUST 4 = Offset-Measure	Measurement operation Mass number adjustment

MODE

Transmit: **CYM** [,x] <CR>[<LF>]
 Receive: <ACK><CR><LF>
 Transmit: <ENQ>[<CR>[<LF>]]
 Receive: x <CR><LF>

Meaning	Values x	Comments
Measurement cycle sequence	0 = MONO 1 = MULTI	Single channel cycle Multichannel cycle

CYCLES

Transmit: **CYS** [,xxxxx] <CR>[<LF>]
 Receive: <ACK><CR><LF>
 Transmit: <ENQ>[<CR>[<LF>]]
 Receive: xxxxx <CR><LF>

Meaning	Values x	Comments
Number of measurement cycles	0 = REPEAT 1 ... 10,000	Continuous cycle repeat

BEGIN

Transmit: **CBE** [,xx] <CR>[<LF>]
 Receive: <ACK><CR><LF>
 Transmit: <ENQ>[<CR>[<LF>]]
 Receive: xx <CR><LF>

Meaning	Values x	Comments
First channel in the cycle	0 ... 63	Only for »multi«, otherwise the first channel is always the selected channel

END

Transmit: **CEN** [,xx] <CR>[<LF>]
 Receive: <ACK><CR><LF>
 Transmit: <ENQ>[<CR>[<LF>]]
 Receive: xx <CR><LF>

Meaning	Values x	Comments
Last channel in the cycle	0 ... 63	Only for »multi«, otherwise the first channel is always the selected channel

TRIG

Transmit: **CTR** [,x] <CR>[<LF>]
 Receive: <ACK><CR><LF>
 Transmit: <ENQ>[<CR>[<LF>]]
 Receive: x <CR><LF>

Meaning	Values x	Comments
Measurement cycle control	0 = INTERN 1 = EXT-AUTO 2 = EXT-NORM 3 = EXT-SNGL	

Run-Time (stop watch)

Transmit: **CWA** [,x] <CR>[<LF>]
 Receive: <ACK><CR><LF>
 Transmit: <ENQ>[<CR>[<LF>]]
 Receive: x,xxx,yy,xx,yyy <CR><LF>

Meaning	Values x, y	Comments
Measurement cycle time	x = 0 ... 1 xxx = 0 ... 119 h yy = 0 ... 59 min xx = 0 ... 59 s yyy = 0 ... 999 ms	0 = LAP off; 1 = LAP on automatic Run Time transmission

ADJ-TYP

Transmit: **CCF** [,x] <CR>[<LF>]
 Receive: <ACK><CR><LF>
 Transmit: <ENQ>[<CR>[<LF>]]
 Receive: x <CR><LF>

Meaning	Values x	Comments
Coarse / fine peak adjustment search	0 = COARSE 1 = FINE	coarse; only in «SAMPLE» fine; only in «SAMPLE»

5.4.4.4 run/halt function**RUN / HALT**

Transmit: **CRU** [,x] <CR>[<LF>]
 Receive: <ACK><CR><LF>
 Transmit: <ENQ>[<CR>[<LF>]]
 Receive: x <CR><LF>

Meaning	Values x	Comments
Start / stop of the measurement cycle	0 = HALT 1 = START 2 = JOB-RUN	

5.4.4.5 filam function**Fila-Emi**

Transmit: **FIE** [,x] <CR>[<LF>]
 Receive: <ACK><CR><LF>
 Transmit: <ENQ>[<CR>[<LF>]]
 Receive: x <CR><LF>

Meaning	Values x	Comments
Emission enabled / disabled	0 = OFF 1 = ON	

5.4.5 Measured data not defined in measurement channels

5.4.5.1 Total pressure

Pirani

Transmit: **TPI** [,x] <CR><LF>
 Receive: <ACK><CR><LF>
 Transmit: <ENQ><CR><LF>]]
 Receive: x,x,y.yEsy <CR><LF>

Meaning	Values x, y	Comments
Pirani total pressure	x = 0 ... 1 x = 0 ... 3 0 = Okay 1 = Underrange 2 = Overrange 3 = Error 1.0 E+3 ... 8.0 E-4	Sensor definition Status for Pirani circuit 1 or 2 Measured data ok Measurement underrange Measurement overrange Error at the measuring unit Pressure value in [mbar]

Penning

Transmit: **TPE** <CR><LF>
 Receive: <ACK><CR><LF>
 Transmit: <ENQ><CR><LF>]]
 Receive: x,y.yEsyy <CR><LF>

Meaning	Values x, y	Comments
Cold cathode pressure	x = 0 ... 4 0 = Okay 1 = Underrange 2 = Overrange 3 = Error 4 = Off 1.0 E-3 ... 5.0 E-10	Cold cathode circuit status Measured data ok Measurement underrange Measurement overrange Error at the measuring unit Measuring unit disabled Pressure value in [mbar]

5.4.5.2 Analog

A-Input

Transmit: **AIN** [,xx] <CR><LF>
 Receive: <ACK><CR><LF>
 Transmit: <ENQ><CR><LF>]]
 Receive: xx,sxxxxx <CR><LF>

Meaning	Values x	Comments
Analog input statuses	xx = 0 ... 15 sxxxxx = -10240 +10238 mV	AI channel Read out AI voltage

A-Output

Transmit: **AOU** [,xx[,sxxxxx]] <CR><LF>
 Receive: <ACK><CR><LF>
 Transmit: <ENQ><CR><LF>]]
 Receive: xx,sxxxxx <CR><LF>

Meaning	Values x	Comments
Analog output statuses	xx = 1 ... 12 99 sxxxxx = -10240 +10238 mV	AO channel All AO channels together Change AO voltage

5.4.5.3 trip STATUS

T-State

Transmit: **TST** <CR><LF>
 Receive: <ACK><CR><LF>
 Transmit: <ENQ><CR><LF>]]
 Receive: x,y <CR><LF>

Meaning	Values x, y	Comments
Switching function statuses for the selected parameter channel	x = 0 ... 1 0 = passive 1 = active y = 0 ... 1 0 = passive 1 = active	Switching function status A Switching function status B

5.4.5.4 Emission

EMI-CUR

Transmit: **ECU** <CR>[<LF>]
 Receive: <ACK><CR><LF>
 Transmit: <ENQ>[<CR>[<LF>]]
 Receive: xxxxx <CR><LF>

Meaning	Values x	Comments
125		
Emission current	0 ... 20.000 µA	

5.4.6 Measured data defined in measurement channels

B-Counter

Transmit: **MBC** <CR>[<LF>]
 Receive: <ACK><CR><LF>
 Transmit: <ENQ>[<CR>[<LF>]]
 Receive: xxxxxx <CR><LF>

Meaning	Values x	Comments
Measured data buffer for intensity counter	0 ... 131.071	0 to 128k

B-Header

Transmit: **MBH** <CR>[<LF>]
 Receive: <ACK><CR><LF>
 Transmit: <ENQ>[<CR>[<LF>]]
 Receive: x,xx,yy,xxxxx,xxx <CR><LF>

Meaning	Values x, y	Comments
Measured data buffer header	x = 0 ... 1 0 = running 1 = ended xx = 0 ... 63 yy = 0 ... 16 xxxxxx = 0 ... 131.071 xxx = 0 ... 120	Measurement status Measurement channel number 0 = No block available 1 = Data type SCAN, STAIR-Integer 2 = Data type PEAK-Integer 7 = Data type SCAN-Float 8 = Data type PEAK-Float 9 = Data type SAMPLE-Float 10 = Data type ADJUST-Float 13 = Data type PIRANI 14 = Data type PENNING 15 = Data type A-INPUT 16 = Data type Run-Time Number of values for the type of data 0 to 128k Counter

5.4.6.1 Electrometer operation

Measured data in scan and stair operation

Transmit: **MDB** <CR>[<LF>]
 Receive: <ACK><CR><LF>
 Transmit: <ENQ>[<CR>[<LF>]]
 Receive: sxxxxx <CR><LF>

Meaning	Values x	Comments
Peak intensity	-10240 ... +10238	[mV]

Measured data in peak processing mode

Transmit: **MDB** <CR>[<LF>]
 Receive: <ACK><CR><LF>
 Transmit: <ENQ>[<CR>[<LF>]]
 Receive: xxxx.xx,syyyyy <CR><LF>

Meaning	Values x, y	Comments
Mass number	0.00 ... 2047.99	Internally in steps of $\frac{1}{64}$ ($\frac{1}{32}$); as a function of the measurement range and «SPEED»
Peak intensity	-10240 ... +10238	[mV]

Measured data in sample mode

Transmit: **MDB** <CR>[<LF>]
 Receive: <ACK><CR><LF>
 Transmit: <ENQ>[<CR>[<LF>]]
 Receive: sx.xxxxxEsxx <CR><LF>

Meaning	Values x	Comments
Peak intensity	1.00000 E-27 9.99999 E+5	E-5 ... E-13 without «CALIB» [A]

Adjust data

Transmit: **MDB** <CR>[<LF>]
 Receive: <ACK><CR><LF>
 Transmit: <ENQ>[<CR>[<LF>]]
 Receive: xx,xx,xxxx.xx,yyyyy <CR><LF>

Meaning	Values x, y	Comments
Status message	xx = 0 ... 31	0 = gut Bit 0 = 1: «MASS» too low Bit 1 = 1: «MASS» too high Bit 2 = 1: Intensity didn't drop to 66% Bit 3 = 1: Intens. > F.S. Bit 4 = 1: Intens. < «THRESH»
Measurement channel number	xx = 0 ... 63	
Mass number	0.00 ... 2047.99	
Peak intensity	-10240 ... +10238	[mV]

Measured data for channel settling (while channel is being changed)

Transmit: **MDB** <CR>[<LF>]
 Receive: <ACK><CR><LF>
 Transmit: <ENQ>[<CR>[<LF>]]
 Receive: xxx,sxxxx <CR><LF>

Meaning	Values x	Comments
Channel measured data rate	1 = 0.1 ms/value 2 = 0.2 ms/value 5 = 0.5 ms/value 10 = 1 ms/value 20 = 2 ms/value 50 = 5 ms/value 100 = 10 ms/value 200 = 20 ms/value 500 = 50 ms/value	
Peak intensity	-10240 ... +10238	[mV]

Measured data for DWELL settling (after channel change)

Transmit: **MDB** <CR>[<LF>]
 Receive: <ACK><CR><LF>
 Transmit: <ENQ>[<CR>[<LF>]]
 Receive: xxx,sxxxx <CR><LF>

Meaning	Values x	Comments
DWELL measured data rate	1 = 0.1 ms/value 2 = 0.2 ms/value 5 = 0.5 ms/value 10 = 1 ms/value 20 = 2 ms/value 50 = 5 ms/value 100 = 10 ms/value 200 = 20 ms/value 500 = 50 ms/value	
Peak intensity	-10240 ... +10238	[mV]

5.4.6.2 Ion counting operation

Measured data in scan and stair operation

Transmit: **MDB** <CR>[<LF>]
 Receive: <ACK><CR><LF>
 Transmit: <ENQ>[<CR>[<LF>]]
 Receive: sx.xxxxEsxx <CR><LF>

Meaning	Values x	Comments
Peak intensity	1.0000 E0 9.9999 E16	E+6 without «CALIB» [cps]

Measured data in Peak Processing Mode

Transmit: **MDB** <CR>[<LF>]
 Receive: <ACK><CR><LF>
 Transmit: <ENQ>[<CR>[<LF>]]
 Receive: xxxx.xx,sy.yyyyEsyy <CR><LF>

Meaning	Values x, y	Comments
Mass number	0.00 ... 2047.99	Internally in steps of $1/64$ ($1/32$); as a function of the measurement range and «SPEED»
Peak intensity	1.0000 E0 9.9999 E16	E+6 without «CALIB» [cps]

Measured data in Sample Mode

Transmit: **MDB** <CR>[<LF>]
 Receive: <ACK><CR><LF>
 Transmit: <ENQ>[<CR>[<LF>]]
 Receive: sx.xxxxxEsxx <CR><LF>

Meaning	Values x	Comments
Peak intensity	1.00000 E0 9.99999 E16	24-bit mantissa; E+6 without «CALIB»; [cps]

Adjust data

Transmit: **MDB** <CR>[<LF>]
 Receive: <ACK><CR><LF>
 Transmit: <ENQ>[<CR>[<LF>]]
 Receive: xx,xx,xxxx.xx,sy.yyyyyEsyy
 <CR><LF>

Meaning	Values x, y	Comments
Status report	xx = 0 ... 31	00 = good Bit 0 = 1: «MASS» too low Bit 1 = 1: «MASS» too high Bit 2 = 1: Intensity didn't drop to 66% Bit 3 = 1: Intens. > F.S. Bit 4 = 1: Intens. < «THRESH»
Measurement channel number	xx = 0 ... 63	
Mass number	0.00 ... 2047.99	
Peak intensity	1.00000 9.99999 E16	[cps]

Measured data for Channel settling (while channel is being changed)

Transmit: **MDB** <CR>[<LF>]
 Receive: <ACK><CR><LF>
 Transmit: <ENQ>[<CR>[<LF>]]
 Receive: xxx,sy.yyyyyEsyy <CR><LF>

Meaning	Values x, y	Comments
Channel measured data rate	1 = 0.1 ms/value 2 = 0.2 ms/value 5 = 0.5 ms/value 10 = 1 ms/value 20 = 2 ms/value 50 = 5 ms/value 100 = 10 ms/value 200 = 20 ms/value 500 = 50 ms/value	
Peak intensity	1.00000 E0 9.99999 E16	[mV]

Measured data for DWELL settling (after channel change)

Transmit: **MDB** <CR>[<LF>]
 Receive: <ACK><CR><LF>
 Transmit: <ENQ>[<CR>[<LF>]]
 Receive: xxx,sy.yyyyyEsyy <CR><LF>

Meaning	Values x, y	Comments
DWELL measured data rate	1 = 0.1 ms/value 2 = 0.2 ms/value 5 = 0.5 ms/value 10 = 1 ms/value 20 = 2 ms/value 50 = 5 ms/value 100 = 10 ms/value 200 = 20 ms/value 500 = 50 ms/value	
Peakintensität	1.00000 E0 9.99999 E16	[mV]

5.4.6.3 Total pressure

Measured data from Pirani measurement

Transmit: **MDB** <CR>[<LF>]
 Receive: <ACK><CR><LF>
 Transmit: <ENQ>[<CR>[<LF>]]
 Receive: x,y.yEsy,x,y.yEsy <CR><LF>

Meaning	Values x, y	Comments
Total pressure Pirani	x = 0 ... 3 0 = Okay 1 = Underrange 2 = Overage 3 = Error 1.0 E+3 ... 8.0 E-4 x = 0 ... 3 0 = Okay 1 = Underrange 2 = Overage 3 = Error 1.0 E+3 ... 8.0 E-4	Status Pirani-Messkreis 1 Status for Pirani circuit 1 Measured data ok Measurement underrange Measurement overrange Error at the measuring unit Pressure in [mbar] Status for Pirani circuit 2 Measured data ok Measurement underrange Measurement overrange Error at the measuring unit Pressure in [mbar]

Measured data from Cold cathode measurement

Transmit: **MDB** <CR>[<LF>]
 Receive: <ACK><CR><LF>
 Transmit: <ENQ>[<CR>[<LF>]]
 Receive: x,y.yEsy <CR><LF>

Meaning	Values x, y	Comments
Total pressure cold cathode	x = 0 ... 4 0 = Okay 1 = Underrange 2 = Overage 3 = Error 4 = Off 1.0 E-3 ... 5.0 E-10	Cold cathode circuit status Measured data ok Measurement underrange Measurement overrange Error at the measuring unit Measuring circuit disabled Pressure in [mbar]

5.4.6.4 Analog

Measured data from Analog input

Transmit: **MDB** <CR>[<LF>]
 Receive: <ACK><CR><LF>
 Transmit: <ENQ>[<CR>[<LF>]]
 Receive: xx,sxxxxx <CR><LF>

Meaning	Values x	Comments
Analog input statuses	xx = 0 ... 15 sxxxxx = -10240 +10238 mV	AI channel Read out AI voltage

5.4.6.5 Run Time

Run Time measured data

Transmit: **MDB** <CR>[<LF>]
 Receive: <ACK><CR><LF>
 Transmit: <ENQ>[<CR>[<LF>]]
 Receive: xxxxx <CR><LF>

Meaning	Values x	Comments
Measurement cycle time	0 ... 232-1 ms	

6 RS-232-C interface (binary)

6.1 Data transmission

The data transmission is bidirectional i.e. data and control commands can be transmitted in either direction.

6.1.1 Definitions

The following abbreviations are used:

Abbreviations and symbols

Symbols	Definition		Decimal	Hex
Computer	Computer or terminal			
QC 422	QC 422 Quadrupol Controller			
<ENQ>	ENQUIRY	Request for data transmission	5	05
<EOT>	END OF TEXT	End of transmission	4	04
<ACK>	ACKNOWLEDGE	Positive report signal	6	06
<NAK>	NEGATIVE ACKNOWLEDGE	Negative report signal	21	15

Terms

"Transmit": Data transfer from the computer to the Quadrupole Controller
 "Empfangen": Data transfer from the Quadrupole Controller to the computer

Floating point data format according to IEEE 754, Single Precision

Sign digit	8-bit exponent	23-bit mantissa
S	E ₇ ... E ₀	M ₂₂ ... M ₀

Range of values:

$$(-1)^S \cdot 1.M \times 2^{(E-127)} \rightarrow 1.17 \times 10^{-38} \dots 3.4 \times 10^{38}$$

Exponent:

8-bit US (unsigned) with an offset of -127 for base 2 number.

Example: $2^3 \rightarrow$ 8-bit Exponent = $127 + 3 = 130$

Mantissa:

Sign digit +23-bit fixed point part for base 2 number with place value without the leading 1.

Number value 0:

Fixed point part and exponent are set to 0. The sign digit retains its validity (+0 and -0 are thus possible).

Number value ∞ :

Mantissa = 0 and exponent = 255. The sign digit distinguishes between $+\infty$ and $-\infty$

Non-numbers (NaN):

Mantissa > 0 and exponent = 255.

6.1.2 Communication protocol (data link)

The data transmission takes place according to the SECS-1 standard (semi equipment communication standard 1).with the following two deviations:

- minimum Header size = 1
- LSB comes before MSB

6.1.2.1 Normalverkehr nach "SECS-1"

Format

The data transmission request <ENQ> must be confirmed by the transmitter with <EOT> before data is transmitted. Once the data has been transmitted, the check sum is transmitted and the transmitter waits for the <ACK> confirmation. When <ACK> is received, the transmission is ended.

Protocol

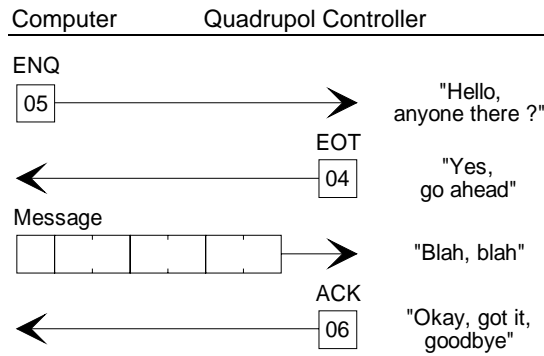

6.1.2.2 Error control according to "SECS-1"

Check sum error

When the checksum turns up an error, <NAK> is output as a transmission confirmation. When <NAK> is received, the previous transmission will be repeated a maximum of six times.

Protocol for check sum error

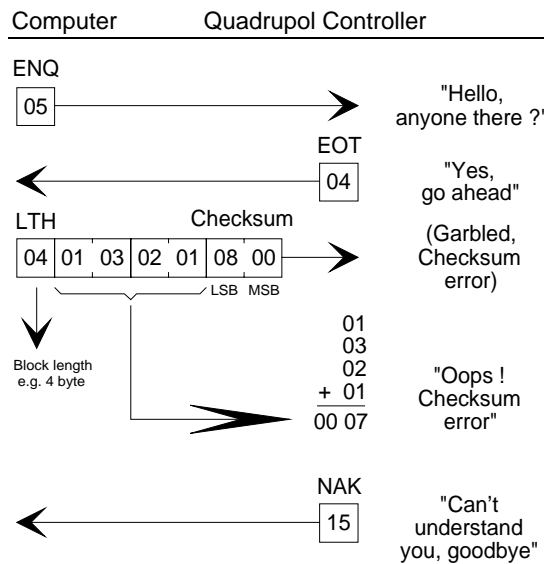

Timeout T1

The receiver only waits for a character for a certain amount of time during a transmission. If this time expires, the transmission is aborted.

Protocol for timeout T1

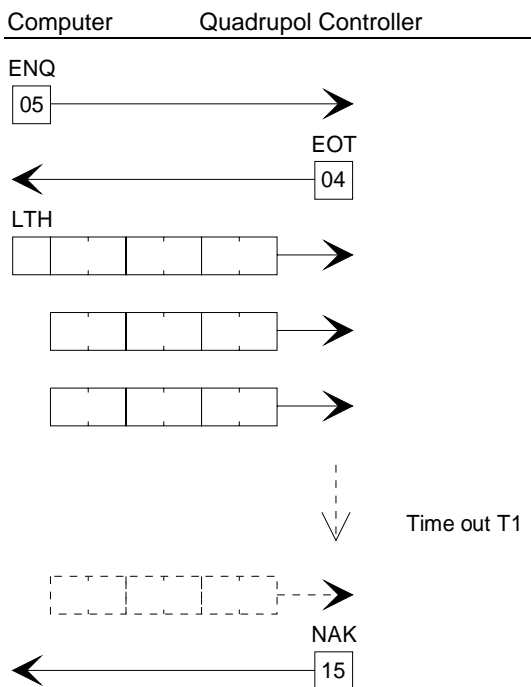

Note
The time between two characters may not be longer than 0.5 s.

Timeout T2

If no there is no response to the data transmission within a cer tain time, the trans-
mission is aborted after seven attempts.
This is the case when the <ENQ> request is not confirmed with <EOT> or when no
message is transmitted after <EOT> or when the transmission is not acknowl-
ged with <ACK> or <NAK>.

Protocol for timeout T2

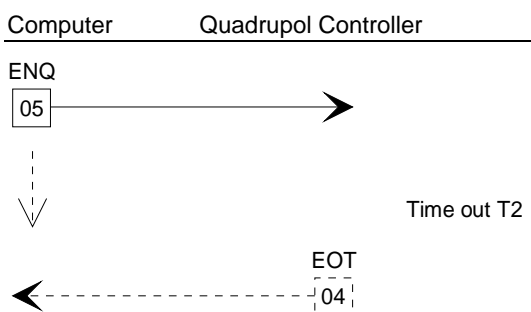

Note
The minimum delay time for the reception of the response is 1 s.

Request collision

If two requests for data transmission are made at the same time, the computer
temporarily postpones its request and confirms the request from the control unit
with <EOT>.

Protocol for collision

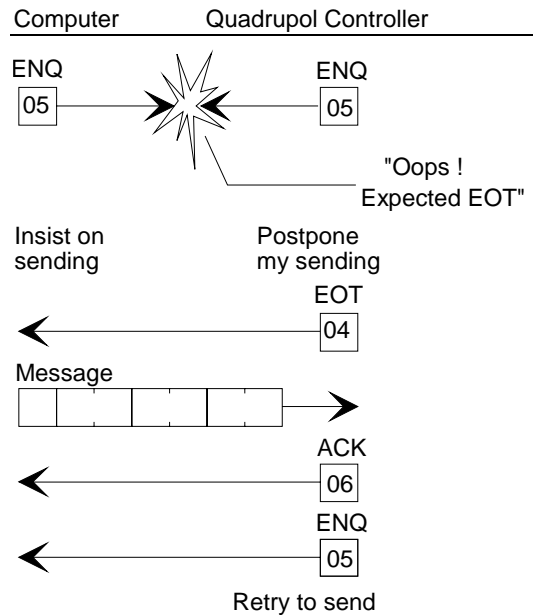

6.1.3 Influencing the measurement by changing a parameter

WARNING

If, as it is entered, a parameter change affects an active measurement cycle, the measured data ring buffer is cleared and the cycle is repeated.

In the same way changes to an *operation* parameter cause the measurement to be repeated.

6.2 Manual / computer operation

Only with the CS 422 control unit:

The switchover: from the console or via the interface, from manual to computer operation can be made manually or via the computer. All entry possibilities have equal status i.e. the input control can switch operation to itself, thereby disabling other controls. Any attempt by the computer to address the QMS 422 in *config* CTRL MODE:CS422 using a block identification that does not equal 38 is acknowledged with <NAK>. In this case there is the danger that the computer always receives an answer.

6.3 Block transfer diagram

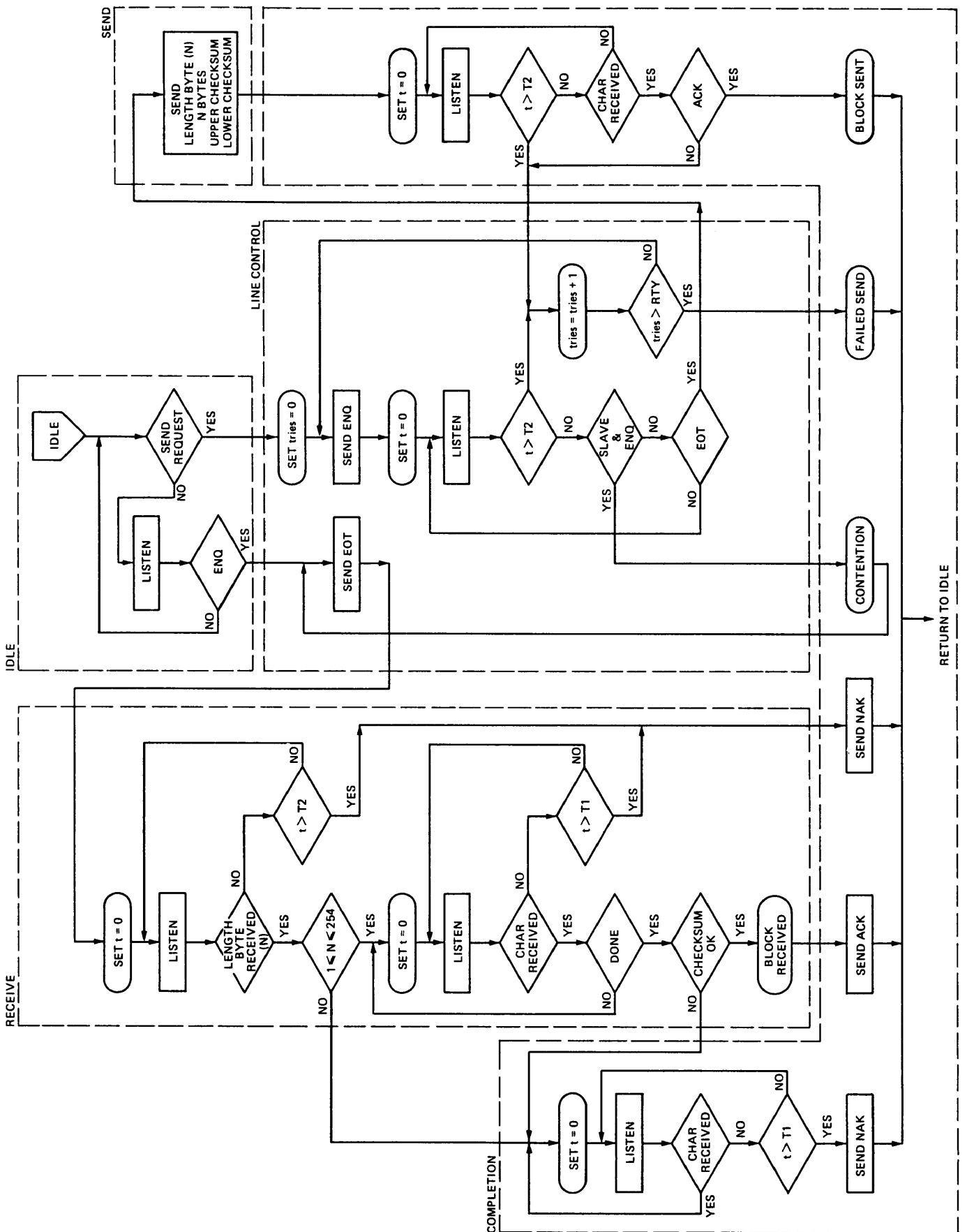

6.4 Block identification

6.4.1 channels group

Frame	Parameter	Block identification	Page	Meaning
<i>select</i>	Measure-Ch	01 / 02	39	Selected measurement channel
	Parameter-Ch	03 / 04	39	Selected parameter channel
<i>detect</i>	TYPE SEM AI-CH / PI-CH	05 / 06	39	Signal source selection SEM high voltage for a channel Analog input or Pirani channel number
	PE-CTRL	103 / 104	40, 56	Enable / disable the cold cathode measurement circuit
<i>mass</i>	MODE FIRST / MASS WIDTH SPEED / DWELL RESOL AVERAGE	07 / 08	41	Spectrum scan operation First mass for a scan / mass number Width of a scan Measurement speed / measurement time Resolution Number of values used for averaging
<i>amplif</i>	MODE RANGE RANGE-L GAIN FILTER CALIB P-CAL	11 / 12	42	Measurement range switching mode Electrometer range Narrowest measurement range for Auto Down Post amplification factor Analog filter setting Calibration factor for the measured value Break factor for changing the measurement channel in multichannel operation
	CP-LEV P-Time	69 / 70	43	Response threshold for the ion counter preamplifier Break time for measurement channel switchover
<i>aux</i>	STATE	13 / 14	43	Enable measurement channel
	COPY TO CH	16	43	Copy the parameter set to channel xx
<i>output</i>	AO-CH AO-MODE MONITOR LOG-DEC O-RNG	17 / 18	44	Analog output channel number Analog output mode Analog output monitor Logarithmic presentation at analog output Display range
<i>trip</i>	TYPE LEVEL-A LEVEL-B DO-A DO-B	19 / 20	44	Type of switching function Switching function A / lower threshold for switching funct. Switching function B / upper threshold for switching funct. Digital output bit number for switching function A Digital output bit number for switching function B

6.4.2 general group

Frame	Parameter	Block identification	Page	Meaning
<i>di/do</i>	DIG-IN	23 / 24	45	Digital input status (block operation)
		25 / 26	45	" (single bit operation)
	DIG-OUT	27 / 28	46	Digital output control (block operation)
		29 / 30	46	" (single bit operation)
<i>config</i> SYSTEM	QMA MASS-R DETECT IS-TYP OPTION	31 / 32	47	Type of analyzer Type of RF generator Type of ion detector Type of ion source System expansion information
<i>config</i> QMS-HW	QMS-HW	33 / 34	47	Pc boards in the QMS 422
<i>config</i> INIT	RESET	36	48	Parameter set (standard / user)
<i>config</i> CTRL	MODE	37 / 38	48	Select type of input
	BAUD			Transmission speed for the RS 232 C interface
	NODE			Node address for the LAN interface
	SEM+FIL			SEM and filament supply
<i>config</i> SIMUL	SIMUL	71 / 72	48	Simulated test spectrum
<i>config</i> TEST	QMS	39 / 40	49	RAM test, EPROM test, program number
	DSP			RAM test, EPROM test, program number
<i>error</i> STATUS	ERROR	41 / 42	50	Error message from QC 422
	Warning			Warning from QC 422
	State-QMS			Control unit status (only interface)

6.4.3 ion source group

Function	Parameter	Block identification	Page	Meaning
<i>emiss</i>	EMISS	43 / 44	51	Emission current
	E-PROT			Max. filament current
<i>v1...v6</i>	V1 IONREF	45 / 46	51	Ion source voltage 1
	V2 CATH			Ion source voltage 2
	V3 FOCUS			Ion source voltage 3
	V4 F-AXIS			Ion source voltage 4
	V5 EXTRACT			Ion source voltage 5
	V6 DEF-I			Ion source voltage 6
<i>v7...</i>	V7			Ion source voltage 7
	V8			Ion source voltage 8
	V9 WEHNELT			Ion source voltage 9

6.4.4 operation group

Frame	Parameter	Block identification	Page	Meaning
<i>sem hv</i> <i>sem</i>	SEM-VOLTAGE Control	49 / 50	52	Common SEM high voltage Enable / disable the SEM high voltage
<i>ion src</i>	MODE TYPE FILAM FIL1 FIL2 Emi-Disp COPY D-TIME D-EMIS D-PROT CTRL	51 / 52 53 / 54 55 / 56 57 / 58	52 53 53 53	Type of ion source operation Type of ion source Filament change Ion source set number for Filament 1 Ion source set number for Filament 2 Enable / disable the emission current display Copy the ion source set Duration of degas process Emission current for degas Maximum filament current for degas Enable / disable degas
<i>cycle</i>	FUNCT MODE CYCLES BEGIN END TRIG Run-Time ADJ-TYP	59 / 60 61 / 62 63 / 64	54 54 54	Measurement cycle operation Measurement cycle sequence Number of measurement cycles First channel in cycle Last channel in cycle Measurement cycle control Scan time Measurement cycle Coarse / fine peak adjustment
<i>run / halt</i>	RUN / HALT	65 / 66	55	Start / Stop the measurement cycle
<i>filam</i>	Fila-Emi	67 / 68	55	Enable / disable the emission

6.4.5 Group of measured data not defined by a channel

Frame	Parameter	Block identification	Page	Meaning
TOTAL	Pirani Penning	101 / 102 103 / 104	56 56, 40	Total pressure Pirani Total pressure cold cathode
ANALOG	A-Input A-Output	105 / 106 107 / 108	57 57	Analog input status Analog output status
<i>trip</i> STATUS	T-State	109 / 110 111 / 112	58 58	Switching function status (block operation) " (single bit operation)
EMIS	EMI-CUR	113 / 114	59	Emission current display on the QME 125
Offset-Value		119 / 120	59	

6.4.6 Group of measured data defined by a channel

Frame	Parameter	Block identification	Page	Meaning
MESSDATA	B-Counter M-Counter M-State M-Data Type B-Header B-Data	131 / 132 133 / 134	60 61-69	Contents counter for measured data buffer Number of measured values for this type of data Measurement is running / has finished Type of data Measured data buffer header Measured data buffer

6.5 Description

6.5.1 channels group

6.5.1.1 select frame

Measurement channel

Read parameters		Transmit parameters					
Transmit: Block 01		Transmit: Block 02					
Receive: Block 02							
Block 01	Block 02	Parameter	Variable type	Mne	Comments		
Byte	Byte		8-bit US		Block length		
1	1	channel	8-bit US	SMC	Block identification		
	2		8-bit US		Selected measurement channel		
			16-bit US		Check sum		
Check sum	Check sum						
LSB	LSB						
MSB	MSB						

Parameter channel (load channel)

Read parameters		Transmit parameters					
Transmit: Block 03		Transmit: Block 04					
Receive: Block 04							
Block 03	Block 04	Parameter	Variable type	Mne	Comments		
Byte	Byte		8-bit US		Block length		
1	1	channel	8-bit US	SPC	Block identification		
	2		8-bit US		Selected parameter channel		
			16-bit US		Check sum		
Check sum	Check sum						
LSB	LSB						
MSB	MSB						

6.5.1.2 detect frame

Read parameters		Transmit parameters					
Transmit: Block 05		Transmit: Block 06					
Receive: Block 06							
Block 05	Block 06	Parameter	Variable type	Mne	Comments		
Byte	Byte		8-bit US		Block length		
1	1	channel	8-bit US	SPC	Block identification		
	2		8-bit US		Selected parameter channel		
	3		8-bit US		0 = Farad; 1 = SEM 2 = Ion-Cnt; 3 = Extern 4 = Pirani; 5 = Penning 6 = A-Input		
	4	SEM	16-bit US	DSE	0 = Common high voltage 1 ... 3500 V		
	5	"	8-bit US		GAP (empty byte)		
	6	AI-CH / PI-CH	8-bit US	DAI	AI-CH = 0 ... 15 or PI-CH = 0 ... 1, according to TYPE		
	7		8-bit US		GAP (empty byte)		
	8		8-bit US		GAP (empty byte)		
	9		8-bit US		GAP (empty byte)		
Check sum	Check sum		16-bit US		Check sum		
LSB	LSB						
MSB	MSB						

Cold cathode control parameters

Read parameters		Transmit parameters					
Transmit: Block 103		Transmit: Block 104					
Receive: Block 104							
Block 103		Block 104		Parameter	Variable type	Mne	Comments
Byte		Byte					
	1		7		8-bit US		Block length
1	103	1	104	PE-CTRL	8-bit US	DPC	Block identification
		2	0 ... 1		8-bit US		0 = Turn off measurement circuit 1 = Turn on measurement circuit
		3	0		8-bit US	GAP (empty byte)	
		4	0		FLOAT	GAP (empty byte)	
		5				GAP (empty byte)	
		6				GAP (empty byte)	
		7				GAP (empty byte)	
	Check sum		Check sum		16-bit US		Check sum
	LSB		LSB				
	MSB		MSB				

 **Note**

Bytes 3 ... 7 have no significance for data transmission. The frame content corresponds to that given in section 6.5.5.1 (cold cathode data) for data reception.

6.5.1.3 mass frame

Read parameters		Transmit parameters					
Transmit: Block 07		Transmit: Block 08					
Receive: Block 08							
Byte	Block 07	Byte	Block 08	Parameter	Variable type	Mne	Comments
	2	14			8-bit US		Block length
1	07	08			8-bit US		Block identification
2	0 ... 63	0 ... 63		channel	8-bit US	SPC	Selected parameter channel
		0 ... 5		MODE	8-bit US	MMO	0 = Scan-N; 1 = Scan-F 2 = Stair; 3 = Sample 4 = Peak-L; 5 = Peak-F
		0 ... LSB		FIRST / MASS	32-bit US	MFM	0.00 ... 2047.99 u
		"		"			
		"		"			
		... 204,799 MSB		"			
		-2047 ... LSB		WIDTH	16-bit S	MWI	-2047 ... +2047 u
		... +2047 MSB		"			
		0 ... 15		SPEED / DWELL	8-bit US	MSD	0 = 0.5 ms/amu; 1 = 1 ms/amu 2 = 2 ms/amu; 3 = 5 ms/amu 4 = 10 ms/amu; 5 = 20 ms/amu 6 = 50 ms/amu; 7 = 0.1 s/amu 8 = 0.2 s/amu; 9 = 0.5 s/amu 10 = 1 s/amu; 11 = 2 s/amu 12 = 5 s/amu; 13 = 10 s/amu 14 = 20 s/amu; 15 = 60 s/amu
		0 ... 255		RESOL	8-bit US	MRE	<input type="checkbox"/> 400 0 = off (integral spectr.) 1 ... 255 = Peak width <input type="checkbox"/> 125 0 = off (integral spectr.) 1 = on (standard spectr.)
		0 ... 7		THRESH	8-bit US	MTH	see the following tables ①
		0 ... 10		AVERAGE	8-bit US	MAV	2 ⁰ = averaging 2 ¹ ... 2 ¹⁰ = number of steps for averaging
		0 ... 2		Steps	8-bit US	MST	see the following tables ② + ③
	Check sum	Check sum			16-bit US		Check sum
	LSB	LSB					
	MSB	MSB					

Table ①

Threshold for peak processor		
Electrometer mode in Fix range	Electrometer mode in Auto range	Ion counting mode
0 = 0.01 %F.S.	0 = 1E-15 A	0 = 10 ⁰ cps
1 = 0.03 %F.S.	1 = 1E-14 A	1 = 10 ¹ cps
2 = 0.1 %F.S.	2 = 1E-13 A	2 = 10 ² cps
3 = 0.3 %F.S.	3 = 1E-12 A	3 = 10 ³ cps
4 = 1 %F.S.	4 = 1E-11 A	4 = 10 ⁴ cps
5 = 3 %F.S.	5 = 1E-10 A	5 = 10 ⁵ cps
6 = 10 %F.S.	6 = 1E-9 A	6 = 10 ⁶ cps
7 = 30 %F.S.	7 = 1E-8 A	7 = 10 ⁷ cps
referenced to RANGE		

Table ②

Mass scale resolution for Fix range				
Steps	SPEED: 0.5 ms/amu 1 ms/amu	SPEED: 2 ms/amu 5 ms/amu	SPEED: from 10 ms/amu	SPEED: from 10 ms/amu
	MASS-R: all	MASS-R: all	MASS-R: to 1024	MASS-R: 2048
0	1/4 u	1/8 u	1/16 u	1/8 u
1	1/8 u	1/16 u	1/32 u	1/16 u
2	1/16 u	1/32 u	1/64 u	1/32 u

Pause time parameters

Read parameters		Transmit parameters					
Transmit: Block 69		Transmit: Block 70					
Receive: Block 70							
Block 69		Block 70		Parameter	Variable type	Mne	Comments
Byte	2	Byte	6		8-bit US		Block length
1	69	1	70		8-bit US		Block identification
2	0 ... 63	2	0 ... 63	channel	8-bit US	SPC	Selected parameter channel
		3	0		8-bit US		GAP (empty byte)
		4	0 ... LSB	P-Time	16-bit US	APT	Pause time for channel changeover
		5	... 65,535 MSB	"			Resolution = 1 ms
		6	0		8-bit US		GAP (empty byte)
Check sum	LSB	Check sum	LSB		16-bit US		Check sum
	MSB		MSB				

6.5.1.5 aux frame

Channel status

Read parameters		Transmit parameters					
Transmit: Block 13		Transmit: Block 14					
Receive: Block 14							
Block 13		Block 14		Parameter	Variable type	Mne	Comments
Byte	2	Byte	3		8-bit US		Block length
1	13	1	14		8-bit US		Block identification
2	0 ... 63	2	0 ... 63	channel	8-bit US	SPC	Selected parameter channel
		3	0 ... 1	STATE	8-bit US	AST	0 = enable; 1 = skip
Check sum	LSB	Check sum	LSB		16-bit US		Check sum
	MSB		MSB				

Copy parameter

		Transmit parameters					
		Transmit: Block 16					
		Block 16		Parameter	Variable type	Mne	Comments
		Byte	4		8-bit US		Block length
		1	16		8-bit US		Block identification
		2	0 ... 63	Copy ch	8-bit US	ACO	Source channel for parameters
		3	0 ... 63	Copy to	8-bit US	ACO	Target channel for parameters
		4	0 ... 2	Copy art	8-bit US	ACO	0 = to all channels 1 = to one channel 2 = swap
		Check sum	LSB		16-bit US		Check sum
			MSB				

6.5.1.6 output frame

Read parameters		Transmit parameters					
Transmit: Block 17		Transmit: Block 18					
Receive: Block 18							
Block 17		Block 18		Parameter	Variable type	Mne	Comments
Byte	2	Byte	7		8-bit US		Block length
1	17	1	18		8-bit US		Block identification
2	0 ... 63	2	0 ... 63	channel	8-bit US	SPC	Selected parameter channel
		3	0 ... 12	AO-CH	8-bit US	OAC	0 = no channel 1 ... 12 = Channel 1...12
		4	0 ... 1	AO-MODE	8-bit US	OMO	0 = lin; 1 = log
		5	0 ... 1	MONITOR	8-bit US	OAM	0 = lin; 1 = log; 2 = RNG code
		6	0 ... 1	LOG-DEC	8-bit US	ODC	Only for ion counting operation 0 = 3 decades; 1 = 10 decades
		7	-12 ... +8	O-RNG	8-bit US	ORA	Exponent for the display range
					16-bit US		Check sum
	Check sum LSB		Check sum LSB				
	MSB		MSB				

6.5.1.7 trip frame

Read parameters		Transmit parameters					
Transmit: Block 19		Transmit: Block 20					
Receive: Block 20							
Block 19		Block 20		Parameter	Variable type	Mne	Comments
Byte	2	Byte	13		8-bit US		Block length
1	19	1	20		8-bit US		Block identification
2	0 ... 63	2	0 ... 63	channel	8-bit US	SPC	Selected parameter channel
		3	0 ... 2	TYPE	8-bit US	TTY	0 = off; 1 = absolute 2 = hysteresis
		4	according to IEEE 754	LEVEL-A	FLOAT	TLA	Switching function A / lower threshold value for the switching function 1.00 E-24 ... 9.99 E+24
		5		"			
		6		"			
		7		"			
		8	according to IEEE 754	LEVEL-B	FLOAT	TLB	Switching function B / upper threshold value for the switching function 1.00 E-24 ... 9.99 E+24
		9		"			
		10		"			
		11		"			
		12	0 ... 95 (99)	DO-A	8-bit US	TDA	DO bit for switching function A (99 = off)
		13	0 ... 95 (99)	DO-B	8-bit US	TDB	DO bit for switching function B (99 = off)
					16-bit US		Check sum
	Check sum LSB		Check sum LSB				
	MSB		MSB				

6.5.2 general group

6.5.2.1 di/do frame

DI statuses (block operation)

Read parameters							
Transmit: Block 23							
Receive: Block 24							
Block 23		Block 24		Para- meter	Variable type	Mne	Comments
Byte		Byte			8-bit US		Block length
	1		9		8-bit US		Block identification
1	23	1	24	DIG-IN	8-bit US	-	Bit 0.. 7: 0 = low; 1 = high
		2	0 ... 255	"	8-bit US		Bit 8..15: 0 = low; 1 = high
		3	0 ... 255	"	8-bit US		Bit 16..23: 0 = low; 1 = high
		4	0 ... 255	"	8-bit US		Bit 24..31: 0 = low; 1 = high
		5	0 ... 255	"	8-bit US		Bit 32..39: 0 = low; 1 = high
		6	0 ... 255	"	8-bit US		Bit 40..47: 0 = low; 1 = high
		7	0 ... 255	"	8-bit US		Bit 48..55: 0 = low; 1 = high
		8	0 ... 255	"	8-bit US		Bit 56..63: 0 = low; 1 = high
		9	0 ... 255	"	8-bit US		
	Check sum		Check sum		16-bit US		Check sum
	LSB		LSB				
	MSB		MSB				

DI statuses (single bit operation)

Read parameters							
Transmit: Block 25							
Receive: Block 26							
Block 25		Block 26		Para- meter	Variable type	Mne	Comments
Byte		Byte			8-bit US		Block length
	2		3		8-bit US		Block identification
1	25	1	26	DIG-IN	8-bit US	DIS	Selected DI bit
2	0 ... 63	2	0 ... 63		8-bit US		0 = low; 1 = high
		3	0 ... 1		8-bit US		
	Check sum		Check sum		16-bit US		Check sum
	LSB		LSB				
	MSB		MSB				

DO statuses (block operation)

Read parameters		Transmit parameters					
Transmit: Block 27		Transmit: Block 28					
Receive: Block 28							
Block 27		Block 28		Para- meter	Variable type	Mne	Comments
Byte	1	Byte	13		8-bit US		Block length
	1	1	28		8-bit US		Block identification
	27	2	0 ... 255	DIG-OUT	8-bit US	DOC	Bit 0.. 7: 0 = clear; 1 = set
		3	0 ... 255	"	8-bit US		Bit 8..15: 0 = clear; 1 = set
		4	0 ... 255	"	8-bit US		Bit 16..23: 0 = clear; 1 = set
		5	0 ... 255	"	8-bit US		Bit 24..31: 0 = clear; 1 = set
		6	0 ... 255	"	8-bit US		Bit 32..39: 0 = clear; 1 = set
		7	0 ... 255	"	8-bit US		Bit 40..47: 0 = clear; 1 = set
		8	0 ... 255	"	8-bit US		Bit 48..55: 0 = clear; 1 = set
		9	0 ... 255	"	8-bit US		Bit 56..63: 0 = clear; 1 = set
		10	0 ... 255	"	8-bit US		Bit 64..71: 0 = clear; 1 = set
		11	0 ... 255	"	8-bit US		Bit 72..79: 0 = clear; 1 = set
		12	0 ... 255	"	8-bit US		Bit 80..87: 0 = clear; 1 = set
		13	0 ... 255	"	8-bit US		Bit 88..95: 0 = clear; 1 = set
					16-bit US		Check sum
	Check sum		Check sum				
	LSB		LSB				
	MSB		MSB				

DO statuses (single bit operation)

Read parameters		Transmit parameters					
Transmit: Block 29		Transmit: Block 30					
Receive: Block 30							
Block 29		Block 30		Para- meter	Variable type	Mne	Comments
Byte	2	Byte	3		8-bit US		Block length
	1	1	30		8-bit US		Block identification
	29	2	0 ... 95	DIG-OUT	8-bit US	DOC	Selected DO bit
	0 ... 63	3	0 ... 1		8-bit US		0 = clear; 1 = set
					16-bit US		Check sum
	Check sum		Check sum				
	LSB		LSB				
	MSB		MSB				

6.5.2.2 config SYSTEM frame

Read parameters		Transmit parameters					
Transmit: Block 31		Transmit: Block 32					
Receive: Block 32							
Block 31		Block 32		Para- meter	Variable type	Mne	Comments
Byte	1	Byte	6		8-bit US		Block length
1	31	1	32		8-bit US		Block identification
		2	0 ... 3	QMA	8-bit US	SQA	0 = QMA 125; 1 = QMA 400 2 = QMA 410; 3 = QMA 430 4 = QMA 200 (only for information)
		3	0 ... 7	MASS-R	8-bit US	SMR	0 = 100 1 = 200 2 = 128 3 = 512 4 = 1024 5 = 2048 6 = 340 7 = 300
		4	0 ... 4	DETECT	8-bit US	SDT	0 = Farad; 1 = SEM 2 = CD-SEM; 3 = H-SEM 4 = Channeltron
		5	0 ... 5	IS-TYP	8-bit US	SIT	400 0 = Axial; 1 = CB 2 = Grid; 3 = SPM 4 = Spec+; 5 = Spec-
		6	0 ... 3	OPTION	8-bit US	SOP	125 0 = Axial; 1 = CB 2 = Grid; 3 = SPM
					16-bit US		0 = none; 3 = CP
	Check sum LSB		Check sum LSB				Check sum
	MSB		MSB				

6.5.2.3 config QMS-HW frame

Read parameters							
Transmit: Block 33							
Receive: Block 34							
Block 33		Block 34		Para- meter	Variable type	Mne	Comments
Byte	1	Byte	11		8-bit US		Block length
1	33	1	34		8-bit US		Block identification
		2	0 ... 1	QMS-HW	8-bit US	QHW	0 = none; 1 = HV 420
		3	0 ... 1	"	8-bit US		0 = none; 1 = HV 421
		4	0 ... 1	"	8-bit US		0 = none; 1 = IS 420
		5	0 ... 1	"	8-bit US		0 = none; 1 = AO 422
		6	0 ... 1	"	8-bit US		0 = none; 1 = IC 422
		7	0 ... 3	"	8-bit US		0 = none; 1..3 = DI 420 (Bit 0: DI 420 Nr. 0 0 ... 31 Bit 1: DI 420 Nr. 1 32 ... 63)
		8	0 ... 7	"	8-bit US		0 = none; 1..7 = DO 420 (Bit 0: DO 420 Nr. 0 0 ... 31 Bit 1: DO 420 Nr. 1 32 ... 63 Bit 2: DO 420 Nr. 2 64 ... 95)
		9	0 ... 1	"	8-bit US		0 = none; 1 = AI 421
		10	0 ... 1	"	8-bit US		0 = none; 1 = PI 420
		11	0 ... 1	"	8-bit US		0 = none; 1 = PE 420
	Check sum LSB		Check sum LSB		16-bit US		Check sum
	MSB		MSB				

6.5.2.4 config INIT frame

		Transmit parameters				
		Transmit: Block 36				
	Block 36		Parameter	Variable type	Mne	Comments
Byte	2			8-bit US		Block length
1	36			8-bit US		Block identification
2	0 ... 1	RESET		8-bit US	IRE	0 = no action 1 = default parameters (Factory)
	Check sum			16-bit US		Check sum
	LSB					
	MSB					

6.5.2.5 config CTRL frame

Read parameters		Transmit parameters						
Transmit: Block 37 Receive: Block 38		Transmit: Block 38						
	Block 37		Block 38		Parameter	Variable type	Mne	Comments
Byte	1	Byte	6			8-bit US		Block length
1	37	1	38			8-bit US		Block identification
		2	0 ... 4	MODE		8-bit US	CMO	0 = CS 422 1 = RS-232 ASCII 2 = RS-232 binary 3 = MODEM 4 = LAN
		3	0 ... 5	BAUD		8-bit US	CBR	0 = 300; 1 = 1200 Bit/s 2 = 2400; 3 = 4800 Bit/s 4 = 9600; 5 = 19200 Bit/s
		4	0 ... 255	NODE		8-bit US	CNA	Node address
		5	0 ... 2	SEM+FIL		8-bit US	CSF	0 = internal; 1 = external 2 = Ext prot
		6	0			8-bit US		GAP (empty byte)
	Check sum		Check sum			16-bit US		Check sum
	LSB		LSB					
	MSB		MSB					

6.5.2.6 config SIMUL frame

Read parameters		Transmit parameters						
Transmit: Block 71 Receive: Block 72		Transmit: Block 72						
	Block 71		Block 72		Parameter	Variable type	Mne	Comments
Byte	1	Byte	2			8-bit US		Block length
1	71	1	72			8-bit US		Block identification
		2	0 ... 2	SIMUL		8-bit US	TSI	0 = no simulation 1 = internal simulation 2 = external simulation
	Check sum		Check sum			16-bit US		Check sum
	LSB		LSB					
	MSB		MSB					

6.5.2.7 config TEST frame

Read parameters							
Transmit: Block 39							
Receive: Block 40							
Block 39		Block 40		Parameter	Variable type	Mne	Comments
Byte	2	Byte	15		8-bit US		Block length
1	39	1	40		8-bit US		Block identification
2	0 ... 3; 8 ... 10	2	0 ... 3; 8 ... 10	QMS	8-bit US	TQM	0 = no test 1 = Ram test 2 = Eprom test 3 = Program number
				DSP		TDS	8 = Ram test 9 = Eprom test 10 = Program number
		3	0		8-bit US		GAP (empty byte)
		4	65 ... 90		8-bit ASCII	TPN	Program number (66=B)
		5	65 ... 90		8-bit ASCII		Program number (71=G)
		6	48 ... 57		8-bit ASCII		Program number (0...9)
		:	:				:
		11	48 ... 57		8-bit ASCII		Program number (0...9)
		12	45. 65 ... 90		8-bit ASCII		Program index (45= -)
		13	45. 65 ... 90		8-bit ASCII		Program index (45= -)
		14	0 ... LSB		16-bit US	TCH	Check sum for EPROM test
		15	... 65,535 MSB				
					16-bit US		Check sum
	Check sum LSB		Check sum LSB				
	MSB		MSB				



Note

Depending on the test, there may be a 2 to 3 second delay between transmission (Block 39) and reception (Block 40)..

6.5.2.8 error / STATUS frame

Read parameters		Transmit parameters					
Transmit: Block 41		Transmit: Block 42					
Receive: Block 42							
Block 41	Block 42	Parameter	Variable type	Mne	Comments		
Byte 1: 1	Byte 1: 11		8-bit US		Block length		
1: 41	1: 42		8-bit US		Block identification		
	2: 0 ... LSB	ERROR	32-bit US	ERR	Bit	Error	Bit Error
	3:	"			0:	No. 17	4: No. 21
	4:	"			1:	No. 18	5: No. 22
	5: ... 2 ³² -1 MSB	"			2:	No. 19	6: No. 23
	6: 0 ... LSB	Warning	16-bit US	EWN	3:	No. 20	7: No. 24
	7: ... 2 ¹⁶ -1 MSB	"			8:	No. 25	12: No. 29
	8: 0 ... LSB	State-QMS	16-bit US	ESQ	9:	No. 26	
	9: ... 2 ¹⁶ -1 MSB	"			10:	No. 27	
	10: 0		8-bit US		11:	No. 28	
	11: 0		8-bit US		16:	No. 33	20: No. 37
Check sum	Check sum		16-bit US		17:	No. 34	21: No. 38
LSB	LSB				18:	No. 35	22: No. 39
MSB	MSB				19:	No. 36	23: No. 40
					24:	No. 41	28: No. 45
					25:	No. 42	29: No. 46
					26:	No. 43	30: No. 47
					27:	No. 44	
					Bit	Warning	Bit Warning
					0:	No. 17	4: No. 21
					1:	No. 18	5: No. 22
					2:	No. 19	
					3:	No. 20	
					Bit	Status 0 / 1	
					0:	Cycle halt / run	
					1:	Mono / multi	
					2:	Emission off / on	
					3:	SEM-Supply off / on	
					4:	Wait for external trigger	
					5:	Settling halt / run	
					6:	Integrator background halt / run	
					7:	Electrometer measured value / emission current display	
					8:	Degas off / on	
					9:	Adjust off / on	
					10:	Adjust run	
					11:		
					12:		
					13:		
					14:	Ring buffer empty	
					15:	Ring buffer overflow	
					GAP	(empty byte)	
					GAP	(empty byte)	
					Check sum		

 **Note**

The 'ERROR' and 'Warning' messages are automatically cleared after any query about them has been answered.
When transmitting parameters the 'ERROR' and 'Warning' messages are erased.



Note

The »Ring buffer overflow« status (bit 15) is not cleared until the next measurement cycle is started (»run«).

6.5.3 ion source group

6.5.3.1 emiss frame

Read parameters		Transmit parameters		Parameter	Variable type	Mne	Comments
Transmit: Block 43 Receive: Block 44		Transmit: Block 44					
Block 43		Block 44					
Byte	2	Byte	6		8-bit US		Block length
1	43	1	44		8-bit US		Block identification
2	0 ... 3	2	0 ... 23	IS-Set	8-bit US		Ion source set *)
		3	0 ... 200	EMISS	8-bit US	EMI	0 = off; 0.01 ... 2.00 mA
		4	0 ... LSB	E-PROT	16-bit US	EPR	0.00 ... 5.00 A
		5	... 500 MSB	"			GAP (empty byte)
		6	0		8-bit US		
					16-bit US		Check sum
	Check sum LSB MSB		Check sum LSB MSB				

6.5.3.2 v1...v6/ v7... frame

Read parameters		Transmit parameters		Parameter	Variable type	Mne	Comments
Transmit: Block 45 Receive: Block 46		Transmit: Block 46					
Block 45		Block 46					
Byte	2	Byte	11		8-bit US		Block length
1	45	1	46		8-bit US		Block identification
2	0 ... 3	2	0 ... 23	IS-Set	8-bit US		ion source set *)
		3	0 ... 150	V1	8-bit US	V01	400 0 ... 150 V In steps of 1 V
		4	0 ... 250	V2	8-bit US	V02	400 0.0 ... 125.0 V In steps of 0.5 V
		5	8 ... 128 ... 248	V3	8-bit US	V03	400 +30.0 ... 0.0 ... -30.0 V In steps of 0.25 V
		6	0 ... 240	V4	8-bit US	V04	400 00 ... 60 V In steps of 0.25 V
		7	0 ... 225	V5	8-bit US	V05	400 ... 450 V In steps of 2 V
		8	0 ... 225	V6	8-bit US	V06	400 0 ... 450 V In steps of 2 V
		9	0 ... 250	V7	8-bit US	V07	400 0 ... 250 V In steps of 1 V
		10	3 ... 128 ... 253	V8	8-bit US	V08	400 +125 ... 0 ... -125 V In steps of 1 V
		11	0 ... 240	V9	8-bit US	V09	400 0 ... 60 V In steps of 0.25 V
					16-bit US		Check sum
	Check sum LSB MSB		Check sum LSB MSB				

*) The ion source set comprises two parts:



IS-Typ: 0 ... 5
IS-Set: 0 ... 3

According to <confiq> «SYSTEM»

6.5.4 operation group

6.5.4.1 sem hv / sem frame

Read parameters		Transmit parameters					
Transmit: Block 49		Transmit: Block 50					
Receive: Block 50							
Block 49		Block 50		Parameter	Variable type	Mne	Comments
Byte	1	Byte	4		8-bit US		Block length
1	49	1	50		8-bit US		Block identification
		2	0 ... LSB	SEM-VOLTAGE	16-bit US	SHV	0 ... 3500 V
		3	... 3500 MSB	"			
		4	0 ... 1	Control	8-bit US	SEM	0 = off; 1 = on
					16-bit US		Check sum
	Check sum LSB		Check sum LSB				
	MSB		MSB				

6.5.4.2 ion src frame

Ion source parameters

Read parameters		Transmit parameters					
Transmit: Block 51		Transmit: Block 52					
Receive: Block 52							
Block 51		Block 52		Parameter	Variable type	Mne	Comments
Byte	1	Byte	7		8-bit US		Block length
1	51	1	52		8-bit US		Block identification
		2	0 ... 1	MODE	8-bit US	ISM	0 = standard; 1 = Degas
		3	0 ... 2	TYPE	8-bit US	ITY	400 0 = According to configurat. 1 = Spec+ 2 = Spec-
		4	0 ... 2	FILAM	8-bit US	IFI	400 0 = Filament 1 1 = Filament 2 2 = Filament 1+2
							125 0 = Filament 1 1 = Filament 2
		5	0 ... 3	FIL1	8-bit US	IS1	400 Set 0 ... Set 3
		6	0 ... 3	FIL2	8-bit US	IS2	400 Set 0 ... Set 3
		7	0 ... 1	Emi-Disp	8-bit US	IED	125 0 = Emission current display off (standard operation) 1 = Emission current display on
	Check sum LSB		Check sum LSB		16-bit US		Check sum
	MSB		MSB				

 **Note**

The emission current is output from a separate frame (see section 6.5.5.4).

Set copy parameter

Read parameters		Transmit parameters					
Transmit: Block 53		Transmit: Block 54					
Receive: Block 54							
Block 53	Block 54	Parameter	Variable type	Mne	Comments		
Byte	Byte		8-bit US		Block length		
1	1	IS-Set	8-bit US		Block identification		
	2	COPY	8-bit US	ICS	400	Source set	
	3		8-bit US		400	Destination set	
Check sum	Check sum		16-bit US		Check sum		
LSB	LSB						
MSB	MSB						

Degas parameter

Read parameters		Transmit parameters					
Transmit: Block 55		Transmit: Block 56					
Receive: Block 56							
Block 55	Block 56	Parameter	Variable type	Mne	Comments		
Byte	Byte		8-bit US		Block length		
1	1	D-TIME	8-bit US	IDT	Block identification		
	2	D-EMIS	8-bit US	IDE	400	0 = Manual; 1 ... 99 minutes	
	3	D-PROT	8-bit US	IDP	400	0.0 ... 20.0 mA	
	4		16-bit US		400	0.00 ... 5.00 A	
Check sum	Check sum	"	8-bit US		GAP (empty byte)		
LSB	LSB		16-bit US		Check sum		
MSB	MSB						

Degas control parameter

Read parameters		Transmit parameters					
Transmit: Block 57		Transmit: Block 58					
Receive: Block 58							
Block 57	Block 58	Parameter	Variable type	Mne	Comments		
Byte	Byte		8-bit US		Block length		
1	1	CTRL	8-bit US	ISC	Block identification		
	2		8-bit US		0 = stop; 1 = start / run		
Check sum	Check sum		16-bit US		Check sum		
LSB	LSB						
MSB	MSB						

6.5.4.3 cycle frame

Read parameters		Transmit parameters					
Transmit: Block 59		Transmit: Block 60					
Receive: Block 60							
Block 59		Block 60		Para- meter	Variable type	Mne	Comments
Byte	1	Byte	8		8-bit US		Block length
1	59	1	60		8-bit US		Block identification
		2	0 ... 3	FUNCT	8-bit US	CFU	0 = Cycle; 1 = Adjust 4 = Offset measure
		3	0 ... 1	MODE	8-bit US	CYM	0 = Mono; 1 = Multi
		4	0 ... LSB	CYCLES	16-bit US	CYS	0 = Repeat 1 ... 10,000 cycles
		5	... 10,000 MSB	"			
		6	0 ... 63	BEGIN	8-bit US	CBE	
		7	0 ... 63	END	8-bit US	CEN	
		8	0 ... 3	TRIG	8-bit US	CTR	0 = Internal; 1 = Ext-Auto 2 = Ext-standard; 3 = Ext-Sngl
					16-bit US		Check sum
	Check sum		Check sum				
	LSB		LSB				
	MSB		MSB				

Run Time (watch)

Read parameters							
Transmit: Block 61							
Receive: Block 62							
Block 61		Block 62		Para- meter	Variable type	Mne	Comments
Byte	1	Byte	6		8-bit US		Block length
1	61	1	62		8-bit US		Block identification
		2	0 ... LSB	Watch	32-bit US	CWA	Cycle run time in ms
		3	"	"			
		4	"	"			
		5	... 2 ³² -1 MSB	"			
		6	0 ... 1		8-bit US		0 = LAP off; 1 = LAP on automatically Run Time transmis- sion
					16-bit US		Check sum
	Check sum		Check sum				
	LSB		LSB				
	MSB		MSB				

Adjust parameter

Read parameters		Transmit parameters					
Transmit: Block 63		Transmit: Block 64					
Receive: Block 64							
Block 63		Block 64		Para- meter	Variable type	Mne	Comments
Byte	1	Byte	2		8-bit US		Block length
1	63	1	64		8-bit US		Block identification
		2	0 ... 1	ADJ-TYP	8-bit US	CCF	0 = coarse adjustment 1 = fine adjustment
					16-bit US		Check sum
	Check sum		Check sum				
	LSB		LSB				
	MSB		MSB				

Cycle control parameters (operation state)

Read parameters		Transmit parameters					
Transmit: Block 65		Transmit: Block 66					
Receive: Block 66							
Block 65		Block 66		Para-meter	Variable type	Mne	Comments
Byte	1	Byte	2		8-bit US		Block length
1	65	1	66		8-bit US		Block identification
		2	0 ... 2	RUN / HALT	8-bit US	CRU	0 = stop; 1 = start 2 = job start (auto status)
Check sum LSB		Check sum LSB			16-bit US		Check sum
MSB		MSB					

Job-Start: The measurement cycle is started. When the cycle (measurement job) has been completed, the QC 422 Quadrupole Controller replies to the interface with *error / STATUS* Frame (see section 6.5.2.8).

6.5.4.4 *filam* frame

Filament control parameter

Read parameters		Transmit parameters					
Transmit: Block 67		Transmit: Block 68					
Receive: Block 68							
Block 67		Block 68		Para-meter	Variable type	Mne	Comments
Byte	1	Byte	2		8-bit US		Block length
1	67	1	68		8-bit US		Block identification
		2	0 ... 1	Fila-Emi	8-bit US	FIE	0 = off; 1 = on
Check sum LSB		Check sum LSB			16-bit US		Check sum
MSB		MSB					

6.5.5 Group of measured values not defined in measurement channels

6.5.5.1 TOTAL frame

Pirani data (measured values)

Read parameters							
Transmit:	Block 101						
Receive:	Block 102						
Block 101	Block 102	Parameter	Variable type	Mne	Comments		
Byte	Byte						
1	11		8-bit US		Block length		
1	101		8-bit US		Block identification		
	1	Pirani	8-bit US	TPI	Status of Pirani meas. circuit 1: 0 = measured data ok 1 = outrange situation (too high) 2 = outrange situation (too low) 3 = sensor failure		
	2		8-bit US		Status of Pirani meas. circuit 2: 0 = measured data ok 1 = outrange situation (too high) 2 = outrange situation (too low) 3 = sensor failure		
	3	"	8-bit US		Measured value Pirani 1 [mbar] (Total pressure)		
	4	"	FLOAT		Measured value Pirani 2 [mbar] (Total pressure)		
	5	"					
	6	"					
	7	"					
	8	"	FLOAT				
	9	"					
	10	"					
	11	"					
Check sum	Check sum		16-bit US		Check sum		
LSB	LSB						
MSB	MSB						

Cold cathode data (measured values)

Read parameters							
Transmit:	Block 103						
Receive:	Block 104						
Block 103	Block 104	Parameter	Variable type	Mne	Comments		
Byte	Byte						
1	7		8-bit US		Block length		
1	103		8-bit US		Block identification		
	1	Penning	8-bit US	TPE	0 = Circuit disabled 1 = Circuit enabled		
	2	"	8-bit US		Status cold cathode circuit: 0 = Measured data ok 1 = outrange situation (too high) 2 = outrange situation (too low) 3 = sensor failure 4 = sensor off		
	3	"	8-bit US		Cold cathode measured value [mbar] (Total pressure)		
	4	"	FLOAT				
	5	"					
	6	"					
	7	"					
Check sum	Check sum		16-bit US		Check sum		
LSB	LSB						
MSB	MSB						

6.5.5.3 trip STATUS frame

Switch function statuses (block operation)

Read parameters							
Transmit: Block 109							
Receive: Block 110							
Block 109	Block 110	Para- meter	Variable type	Mne	Comments		
Byte	Byte						
1	17		8-bit US		Block length		
1	110		8-bit US		Block identification		
	2	T-State	8-bit US	-	Switching function A:		
	3	"	8-bit US		Bit 0.. 7: 0 = passive 1 = active		
	4	"	8-bit US		Bit 8..15: 0 = passive 1 = active		
	5	"	8-bit US		Bit 16..23: 0 = passive 1 = active		
	6	"	8-bit US		Bit 24..31: 0 = passive 1 = active		
	7	"	8-bit US		Bit 32..39: 0 = passive 1 = active		
	8	"	8-bit US		Bit 40..47: 0 = passive 1 = active		
	9	"	8-bit US		Bit 48..55: 0 = passive 1 = active		
	10	"	8-bit US		Bit 56..63: 0 = passive 1 = active		
	11	"	8-bit US		Switching function B:		
	12	"	8-bit US		Bit 0.. 7: 0 = passive 1 = active		
	13	"	8-bit US		Bit 8..15: 0 = passive 1 = active		
	14	"	8-bit US		Bit 16..23: 0 = passive 1 = active		
	15	"	8-bit US		Bit 24..31: 0 = passive 1 = active		
	16	"	8-bit US		Bit 32..39: 0 = passive 1 = active		
	17	"	8-bit US		Bit 40..47: 0 = passive 1 = active		
					Bit 48..55: 0 = passive 1 = active		
					Bit 56..63: 0 = passive 1 = active		
			16-bit US		Check sum		
Check sum	Check sum						
LSB	LSB						
MSB	MSB						

Switching function statuses (single bit operation)

Read parameters							
Transmit: Block 111							
Receive: Block 112							
Block 111	Block 112	Para- meter	Variable type	Mne	Comments		
Byte	Byte						
2	4		8-bit US		Block length		
1	112		8-bit US		Block identification		
2	0 ... 63	channel	8-bit US	SPC	Selected parameter channel		
	3	T-State	8-bit US	TST	Switching function A: 0 = passive 1 = active		
	4	"	8-bit US		Switching function B: 0 = passive 1 = active		
					Check sum		
Check sum	Check sum		16-bit US				
LSB	LSB						
MSB	MSB						

6.5.5.4 EMIS frame

Read parameters							
Transmit:	Block 113						
Receive:	Block 114						
Block 113		Block 114		Para- meter	Variable type	Mne	Comments
Byte	1	Byte	3		8-bit US		Block length
1	113	1	114		8-bit US		Block identification
		2	0 ... LSB	EMI-CUR	16-bit US	ECU	125 Emission current display 0 ... 20,000 µA
		3	... 20,000 MSB	"			
					16-bit US		Check sum
	Check sum LSB MSB		Check sum LSB MSB				



Note

To be able to output the emission current value, the unit must be switched to emission current display (see section 6.5.4.2)

6.5.5.5 Offset-Value frame

Read parameters		Transmit parameters					
Transmit:	Block 119	Transmit:	Block 120				
Receive:	Block 120						
Block 119		Block 120		Para- meter	Variable type	Mne	Comments
Byte	1	Byte	47		8-bit US		Block length
1	119	1	120		8-bit US		Block identification
		2	-32,768 ... LSB	OSET-F1	16-bit S	AOF	Offset Faraday E-05
		3	... 32,767 MSB	"			
		4	-32,768 ... LSB	OSET-F2	16-bit S	AOF	Offset Faraday E-06
		5	... 32,767 MSB	"			
		6	-32,768 ... LSB	OSET-F3	16-bit S	AOF	Offset Faraday E-07
		7	... 32,767 MSB	"			
		:	:				:
		16	-32,768 ... LSB	OSET-F8	16-bit S	AOF	Offset Faraday E-12
		17	... 32,767 MSB	"			
		18	-32,768 ... LSB	OSET-N1	16-bit S	AOF	Offset SEM E-05
		19	... 32,767 MSB	"			
		20	-32,768 ... LSB	OSET-N2	16-bit S	AOF	Offset SEM E-06
		21	... 32,767 MSB	"			
		22	-32,768 ... LSB	OSET-N3	16-bit S	AOF	Offset SEM E-07
		23	... 32,767 MSB	"			
		:	:				:
		32	-32,768 ... LSB	OSET-N8	16-bit S	AOF	Offset SEM E-12
		33	... 32,767 MSB	"			
		34	0		16-bit S		GAP (empty byte)
		35	0				
		36	0		16-bit S		GAP (empty byte)
		37	0				
		:	:				:
		46	0		16-bit S		GAP (empty byte)
		47	0				
	Check sum LSB MSB		Check sum LSB MSB		16-bit US		Check sum

 **Note**
 Transmission of block 120 sets all offset values to (Clear).

Signal range: -10.240 V ... +10.240 V
 Resolution: 312.5 µV / LSB

Conversion:
$$I_{offset} = \frac{Value\ OSET - xx}{32000} \times Range$$

6.5.6 Group of measured data defined in channels (cycle data)

No measured data are output when the cycle is not running (»halt«).

6.5.6.1 MEASURED DATA frame

Measured data buffer contents counter

Read parameters							
Transmit:	Block 131						
Receive:	Block 132						
Block 131	Block 132	Parameter	Variable type	Mne	Comments		
Byte	Byte						
1	11		8-bBit US		Block length		
1	131		8-bit US		Block identification		
	1	B-Counter	32-bit US	MBC	Contents counter for measured data buffer = 0 ... 128 k		
	2	"	"	"	"		
	3	"	"	"	"		
	4	"	"	"	"		
	5	M-Counter	32-bit US		Number of measured values for the type of data defined = 0 ... 128 k		
	6	"	"	"	"		
	7	"	"	"	"		
	8	"	"	"	"		
	9	M-State	8-bit US		0 = Measurement in progress 1 = Measurement finished		
	10	"	"	"	"		
	11	M-Data Type	8-bit US		0 = No available block 1 = Data type SCAN, STAIR-Integer 2 = Data type PEAK-Integer 7 = Data type SCAN-Float 8 = Data type PEAK-Float 9 = Data type SAMPLE-Float 10 = Data type ADJUST-Float 13 = Data type PIRANI 14 = Data type PENNING 15 = Datatype A-INPUT 16 = Data type Run Time		
			16-bit US		Check sum		
Check sum	LSB	Check sum	LSB				
	MSB		MSB				

 **Note**
 Data type Integer:
 For Fix range in the SCAN, STAIR, and PEAK modes and for the detector types FARAD, SEM, and EXTERN.
 Data type Float:
 For Auto range in all operating modes and for the detector types FARAD, SEM, and IONCOUNT.

Measured data when no block is available

Read parameters							
Transmit: Block 133							
Receive: Block 134							
Block 133		Block 134		Parameter	Variable type	Mne	Comments
Byte	1	Byte	6		8-bit US		Block length
1	133	1	134	Header	8-bit US		Block identification
		2	0 LSB	"	16-bit US	MDB	Block counter
		3	MSB	"	8-bit US		Measurement channel number
		4	0 ... 63	"	8-bit US		No block available
		5	0	"	8-bit US		GAP (empty byte)
		6	0		16-bit US		Check sum
	Check sum LSB		Check sum LSB				
	MSB		MSB				

6.5.6.2 Data type Integer

SCAN, STAIR Integer measurement data

Read parameters							
Transmit: Block 133							
Receive: Block 134							
Block 133		Block 134		Parameter	Variable type	Mne	Comments
Byte	1	Byte	7 ... max. 245		8-bit US		Block length
1	133	1	134	Header	8-bit US		Block identification
		2	0 ... LSB	"	16-bit US	MDB	Block counter
		3	... 1023 MSB	"	8-bit US		Measurement channel number
		4	0 ... 63	"	8-bit US		Data type SCAN, STAIR Integer
		5	1	Data	16-bit S		Intensity: 0 ... 10.24 V
		6	0 ... LSB	"	16-bit S		Resolution = 312.5 µV/LSB
		7	... 32,767 MSB	"	16-bit S		Intensity: 0 ... 10.24 V
		8	0 ... LSB	"	16-bit S		Resolution = 312.5 µV/LSB
		9	... 32,767 MSB	"	16-bit S		Intensity: 0 ... 10.24 V
		:	:	"	16-bit S		Resolution = 312.5 µV/LSB
		max	0 ... LSB	"	16-bit S		Intensity: 0 ... 10.24 V
		244	... 32,767 MSB	"	16-bit S		Resolution = 312.5 µV/LSB
		245	... 32,767 MSB		16-bit US		Check sum
	Check sum LSB		Check sum LSB				
	MSB		MSB				



Note

The number of measurement values per mass is defined in the Steps parameter in the *mass* frame (see section 6.5.1.3)

PEAK Float measurement data

Read parameters
 Transmit: Block 133
 Receive: Block 134

Block 133		Block 134		Parameter	Variable type	Mne	Comments
Byte	1	Byte	11 ... max. 245		8-bit US		Block length
1	133	1	134		8-bit US		Block identification
		2	0 ... LSB	Header	16-bit US	MDB	Block counter
		3	... 1023 MSB	"			
		4	0 ... 63	"	8-bit US		Measurement channel number
		5	8	"	8-bit US		Data type PEAK-Float
		6	0 ... LSB	Data	16-bit US		Mass number: 0 ... 1023 (2048) Resolution = $1/64$ ($1/32$) amu/Bit
		7	... 65,535 MSB	"			
		8	according to IEEE 754	"	FLOAT		Intensity
		9		"			
		10		"			
		11		"			
		12	0 ... LSB	"	16-bit US		Mass number: 0 ... 1023 (2048) Resolution = $1/64$ ($1/32$) amu/Bit
		13	... 65,535 MSB	"			
		14	according to IEEE 754	"	FLOAT		Intensity
		15		"			
		16		"			
		17		"			
		:	:				:
		max	0 ... LSB	"	16-bit US		Mass number: 0 ... 1023 (2048) Resolution = $1/64$ ($1/32$) amu/Bit
		240	... 65,535 MSB	"			
		241	according to IEEE 754	"	FLOAT		Intensity
		242		"			
		243		"			
		244		"			
		245		"			
			Check sum LSB		16-bit US		Check sum
			MSB				

SAMPLE Float measurement data

Read parameters							
Transmit: Block 133							
Receive: Block 134							
Block 133	Block 134	Parameter	Variable type	Mne	Comments		
Byte	Byte						
1	9 ... max. 245		8-bit US		Block length		
1	133		8-bit US		Block identification		
	1 134		8-bit US		Block counter		
	2 0 ... LSB	Header	16-bit US	MDB			
	3 ... 1023 MSB	"					
	4 0 ... 63	"	8-bit US		Start channel number (Begin)		
	5 9	"	8-bit US		Data type SAMPLE-Float		
	6 according to IEEE 754	Data	FLOAT		Intensity		
	7	"					
	8	"					
	9	"					
	10 according to IEEE 754	"	FLOAT		Intensity		
	11	"					
	12	"					
	13	"					
	:	"			:		
	max	"	FLOAT		Intensity		
	242	"					
	243	"					
	244	"					
	245	"					
Check sum	Check sum		16-bit US		Check sum		
LSB	LSB						
MSB	MSB						

ADJUST Float measurement data

Read parameters
 Transmit: Block 133
 Receive: Block 134

Block 133	Block 134	Parameter	Variable type	Mne	Comments
Byte 1: 1	Byte 13 ... max. 245		8-bit US		Block length
1: 133	1: 134		8-bit US		Block identification
	2: 0 ... LSB	Header	16-bit US	MDB	Block counter
	3: ... 1023 MSB	"	"	"	"
	4: 0 ... 63	"	8-bit US	"	Start channel number (Begin)
	5: 10	"	8-bit US	"	Data type ADJUST-Float
	6: 0 ... 31	Data	16-bit US	"	Status report Bit 0: 0 = good 1 = mass too low (coarse adjust) 1 = no peak found (fine adjust) Bit 1: 0 = good 1 = Mass too high Bit 2: 0 = good 1 = Intensity didn't drop to 66% Bit 3: 0 = good 1 = intensity out-range Bit 4: 0 = good 1 = intensity lower than Threshold
	7:	"	"	"	"
	8: 0 ... LSB	"	16-bit US	"	Mass number: 0 ... 1023 (2048) Resolution = $1/64$ ($1/32$) amu/Bit
	9: ... 65,535 MSB	"	"	"	"
	10: according to IEEE 754	"	FLOAT	"	Intensity
	11:	"	"	"	"
	12:	"	"	"	"
	13:	"	"	"	"
	14: 0 ... 31	Data	16-bit US	"	Status report
	15:	"	"	"	"
	16: 0 ... LSB	"	16-bit US	"	Mass number: 0 ... 1023 (2048) Resolution = $1/64$ ($1/32$) amu/Bit
	17: ... 65,535 MSB	"	"	"	"
	18: according to IEEE 754	"	FLOAT	"	Intensity
	19:	"	"	"	"
	20:	"	"	"	"
	21:	"	"	"	"
	: :	"	"	"	"
	max: 0 ... 31	Data	16-bit US	"	Status report
	238:	"	"	"	"
	239:	"	"	"	"
	240: 0 ... LSB	"	16-bit US	"	Mass number: 0 ... 1023 (2048) Resolution = $1/64$ ($1/32$) amu/Bit
	241: ... 65,535 MSB	"	"	"	"
	242: according to IEEE 754	"	FLOAT	"	Intensity
	243:	"	"	"	"
	244:	"	"	"	"
	245:	"	"	"	"
Check sum LSB	Check sum LSB		16-bit US		Check sum
MSB	MSB				

6.5.6.4 Total pressure measured data from Pirani measurement

Also refer to section 6.5.5.1

Read parameters					
Transmit:	Block 133				
Receive:	Block 134				
Block 133	Block 134	Parameter	Variable type	Mne	Comments
Byte	Byte				
1	15		8-bit US		Block length
1	134		8-bit US		Block identification
	2	Header	16-bit US	MDB	Block counter
	3	"			
	4	"	8-bit US		Measurement channel number
	5	"	8-bit US		Data type PIRANI
	6	Data	8-bit US		Status of Pirani meas. circuit 1: 0 = measured data ok 1 = outrange situation (too high) 2 = outrange situation (too low) 3 = sensor failure
	7	"	8-bit US		Status of Pirani meas. circuit 2: 0 = measured data ok 1 = outrange situation (too high) 2 = outrange situation (too low) 3 = sensor failure
	8	"	FLOAT		Measured value Pirani 1 [mbar]
	9	"			(Total pressure)
	10	"			
	11	"			
	12	"	FLOAT		Measured value Pirani 2 [mbar]
	13	"			(Total pressure)
	14	"			
	15	"			
Check sum	Check sum		16-bit US		Check sum
LSB	LSB				
MSB	MSB				

7 LAN interface

7.1 ARCNET® network

ARCNET® is a 'Local area network' with 'Token passing protocol' (Token Bus). Star topology with fibre optics connections (LWL) is used in the QMS 422 and QMI 422 quadrupole mass spectrometer control units. This topology allows for simple point-to-point connections. If an optical hub is used (e.g. OH 421 optical hub), it is additionally possible to set up networks with up to a maximum of 255 stations (nodes).

Each station has its own identification address (ID) which can be allocated in the network without hierarchical assignment or arrangement. A node address may only be used once.

7.1.1 Token Passing Protocol

Network access is controlled by a "Token" which is passed from one station to another in the network. The station with the "Token" can dispatch a data packet to any other station. After dispatching the data packet, the station must pass on the "Token" to the station with the next highest ID (→ Logical ring organisation).

7.1.2 Reconfiguring the network

The ARCNET is reconfigured automatically every time the network is started or when a station is added or removed during operation.

7.2 Data transmission

Format of data packet

When the QMS 422 is used, data is passed only in 'Short packet' format (255 bytes). The same data frames as for the RS-232-C binary interface are used as data packets (see section). The entire data packet is incorporated in the ARCNET data packet with the exception of the check sum which is annexed to the frame.

ARCNET data packet

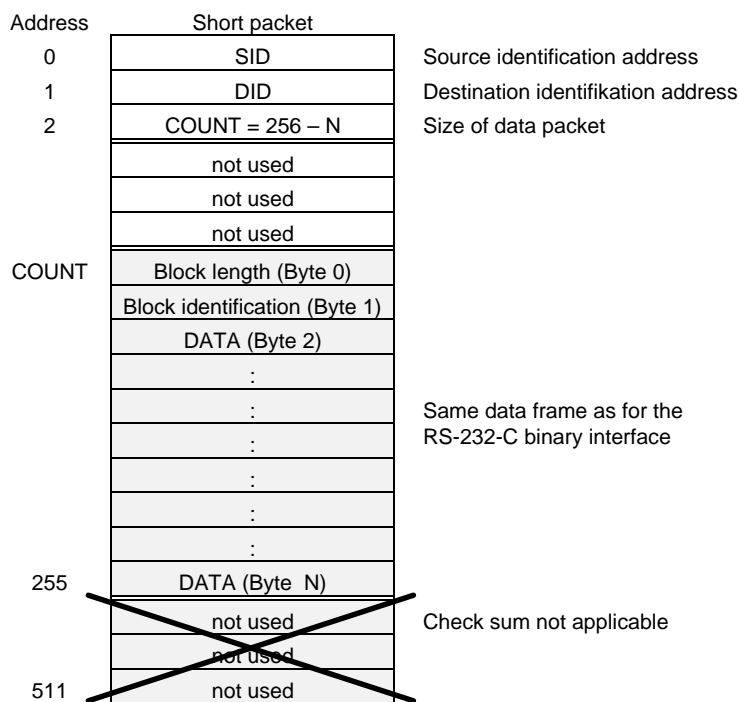

7.3 PC interface

BALZERS offers the OPA 200 ARCNET® Network Controller Board as pc interface for the AT/ISA bus (see [2] and [1]).

Appendix

A Program examples

SCAN measurement with the RS-232-C interface (ASCII format)

```

10 REM *****
20 REM  AVMQMSE.BAS           Measured value query QMS 422           18.05.1997 soro
30 REM
40 REM  Creation Date : 2.November 1996
50 REM  Author       : R. Sonderegger  Abt. KARE
60 REM  Version      : V00.01
70 REM  Modification :
80 REM  Contents     :
90 REM *****
100 CLS : ACK$ = CHR$(6): ENQ$ = CHR$(5): LF$ = CHR$(10): ETX$ = CHR$(3)
110 REM ***<general>***<config>***<CTRL>*****
120 OPEN "COM1:19200,N,8,,CS,DS,CD" FOR RANDOM AS #1
130 REM opens COM1: with 19200 bps, no parity and eight data bits.
140 REM CTS, DSR and CD are not checked.
150 COM(1) ON: REM Aktiviert Ereignisverfolgung
160 ON COM(1) GOSUB 400
170 CBR% = 5: CMOACK% = 0: GOTO 230
180 OPEN "COM1:9600,N,8,,CS,DS,CD" FOR RANDOM AS #1: GOTO 230
190 OPEN "COM1:4800,N,8,,CS,DS,CD" FOR RANDOM AS #1: GOTO 230
200 OPEN "COM1:2400,N,8,,CS,DS,CD" FOR RANDOM AS #1: GOTO 230
210 OPEN "COM1:1200,N,8,,CS,DS,CD" FOR RANDOM AS #1: GOTO 230
220 OPEN "COM1:300,N,8,,CS,DS,CD" FOR RANDOM AS #1
230 PRINT #1, ETX$; : REM clearing the input buffer of the QMS422
240 PRINT #1, "CMO,1": REM send measurement data or parameters in ASCII strings
250 FOR J = 1 TO 4000: NEXT J' delay four seconds
260 IF CMOACK% = 128 THEN GOTO 370
270 CLOSE
280 IF CBR% = 0 THEN CBR% = 6
290 CBR% = CBR% - 1
300 IF CBR% = 4 THEN PRINT "check 9600 BAUD": GOTO 180
310 IF CBR% = 3 THEN PRINT "check 4800 BAUD": GOTO 190
320 IF CBR% = 2 THEN PRINT "check 2400 BAUD": GOTO 200
330 IF CBR% = 1 THEN PRINT "check 1200 BAUD": GOTO 210
340 IF CBR% = 0 THEN PRINT "check 300 BAUD": GOTO 220
350 CBR% = 5: PRINT "check 19200 BAUD"
360 GOTO 120
370 IF CBR% = 5 THEN GOTO 410
380 PRINT #1, "CBR,5": PRINT "send baud rates 19200 BAUD"
390 CLOSE : GOTO 120
400 CMOACK% = 128: RETURN
410 COM(1) OFF
420 C$ = INPUT$(LOC(1), #1): REM clearing the input buffer of the PC
430 PRINT "19200 BAUD"
440 REM ***<general>***<config>***<SYSTEM>*****
450 INPUT "defines the system configuration ? (Y/N)"; IN$
460 IF IN$ = "n" OR IN$ = "N" THEN GOTO 670
470 IF IN$ = "y" OR IN$ = "Y" THEN GOTO 490
480 GOTO 450
490 PRINT #1, "SQA": REM query for type of analyzer
500 GOSUB 1380: IF RETRY% > 0 THEN GOTO 490' communications protocol
510 PRINT #1, ENQ$; : REM request for data transmission
520 LINE INPUT #1, SQA$: REM reading the type of analyzer
530 IF SQA$ = "0" THEN GOTO 620
540 PRINT #1, "SQA,0": PRINT "SQA,0  type of analyzer QMA 125"
550 GOSUB 1380: IF RETRY% > 0 THEN GOTO 540' communications protocol
560 INPUT "mass range 200 (Y/N)"; IN$
570 SMR$ = "0": REM mass range 100
580 IF IN$ = "y" OR IN$ = "Y" THEN SMR$ = "1"
590 PRINT #1, "SMR," + SMR$
600 PRINT "SMR,"; SMR$; "QMA125 mass range 100 or 200"
610 GOSUB 1380: IF RETRY% > 0 THEN GOTO 590' communications protocol
620 INPUT "type of ion detection SEM (Y/N)"; IN$
630 SDT$ = "0": REM ion detection FARADAY
640 IF IN$ = "y" OR IN$ = "Y" THEN SDT$ = "1"
650 PRINT #1, "SDT," + SDT$: PRINT "SDT,"; SDT$; " ion detection SEM or FARADAY"
660 GOSUB 1380: IF RETRY% > 0 THEN GOTO 650' communications protocol
670 INPUT "vacuum <=10^4 mbar (Y/N)"; IN$
680 IF IN$ = "n" OR IN$ = "N" THEN GOTO 790
690 IF IN$ = "y" OR IN$ = "Y" THEN GOTO 710
700 GOTO 670
710 PRINT #1, "SEM,1": PRINT "SEM,1  enable the SEM high voltage"
720 GOSUB 1380: IF RETRY% > 0 THEN GOTO 710' communications protocol
730 PRINT #1, "FIE,1": PRINT "FIE,1  enable the emission"

```

```

740 GOSUB 1380: IF RETRY% > 0 THEN GOTO 730' communications protocol
750 PRINT #1, "TSI,0": PRINT "TSI,0  simulated test spectrum OFF"
760 GOSUB 1380: IF RETRY% > 0 THEN GOTO 750' communications protocol
770 TIMERTXT$ = " SCAN-FIR mass spectrum mass 0-100          "
780 GOTO 820
790 PRINT #1, "TSI,1": PRINT "TSI,1  simulated test spectrum INTERN"
800 GOSUB 1380: IF RETRY% > 0 THEN GOTO 790' communications protocol
810 TIMERTXT$ = " SCAN !! simulated test spectrum INTERN !!  "
820 REM ***<operation>*<cycle>*****
830 PRINT #1, "CFU,0": PRINT "CFU,0  measurement operation CYCLE"
840 GOSUB 1380: IF RETRY% > 0 THEN GOTO 830' communications protocol
850 PRINT #1, "CYM,0": PRINT "CYM,0  single channel cycle MONO"
860 GOSUB 1380: IF RETRY% > 0 THEN GOTO 850' communications protocol
870 PRINT #1, "CYS,1": PRINT "CYS,1  number of measurement cycles"
880 GOSUB 1380: IF RETRY% > 0 THEN GOTO 870' communications protocol
890 REM ***<channels>*****
900 PRINT #1, "SPC,6": PRINT "SPC,6  selected parameter channel"
910 GOSUB 1380: IF RETRY% > 0 THEN GOTO 900' communications protocol
920 PRINT #1, "SDT": REM ion detection SEM or FARADAY
930 GOSUB 1380: IF RETRY% > 0 THEN GOTO 920' communications protocol
940 PRINT #1, ENQ$; : INPUT #1, SDT$' request for data transmission
950 PRINT #1, "DTY,"; SDT$: PRINT "DTY,"; SDT$; " ion detection SEM or FARADAY"
960 GOSUB 1380: IF RETRY% > 0 THEN GOTO 950' communications protocol
970 PRINT #1, "MMO,1": PRINT "MMO,1  scan with FIR filter"
980 GOSUB 1380: IF RETRY% > 0 THEN GOTO 970' communications protocol
990 PRINT #1, "MSD,6": PRINT "MSD,6  measurement speed per amu 50 ms"
1000 GOSUB 1380: IF RETRY% > 0 THEN GOTO 990' communications protocol
1010 PRINT #1, "ARA,-9": PRINT "ARA,-9  electrometer range"
1020 GOSUB 1380: IF RETRY% > 0 THEN GOTO 1010' communications protocol
1030 PRINT #1, "MST,0": PRINT "MST,0  points per mass 1/16"
1040 GOSUB 1380: IF RETRY% > 0 THEN GOTO 1030' communications protocol
1050 PRINT #1, "MFM,0": PRINT "MFM,0  first mass"
1060 GOSUB 1380: IF RETRY% > 0 THEN GOTO 1050' communications protocol
1070 PRINT #1, "MWI,100": PRINT "MWI,100 width of a scan"
1080 GOSUB 1380: IF RETRY% > 0 THEN GOTO 1070' communications protocol
1090 REM *** START SCAN *****
1100 PRINT #1, "CRU,2": PRINT "CRU,2 JOB-RUN the measurement cycle is started!"
1110 GOSUB 1380: IF RETRY% > 0 THEN GOTO 1100' communications protocol
1120 GOSUB 1600: IF LOC(1) = 0 THEN GOTO 1120: REM time display
1130 LINE INPUT #1, ESQ$: REM waiting for measurement job completed
1140 PRINT #1, "MBH": REM query for measured data header
1150 GOSUB 1380: IF RETRY% > 0 THEN GOTO 1140' communications protocol
1160 PRINT #1, ENQ$; : REM request for data transmission
1170 INPUT #1, S%, C%, B%, M%, Z%: REM reading the measured data header
1180 PRINT #1, "MDB": REM query for measured data in scan operation
1190 GOSUB 1380: IF RETRY% > 0 THEN GOTO 1180' communications protocol
1200 REM *** reading the QMS422 measured values *****
1210 FOR I% = 1 TO M%: number of peak intensity
1220 GOSUB 1500: REM measured values transmission
1230 SCANDATA = VAL(mdata$): REM peak intensity
1240 REM *** display of measured values *****
1250 PRINT USING " MASS:###.## #####"; I% / 16; SCANDATA;
1260 PRINT STRING$(ABS(SCANDATA) / 200, 219)
1270 GOSUB 1600: REM time display
1280 FOR J = 0 TO 100: NEXT J' display delay 1/10 second
1290 REM *** press any key to stop the screen from scrolling *****
1300 T$ = INKEY$: IF T$ = "" THEN GOTO 1360
1310 TEMPTEXT$ = TIMERTXT$
1320 TIMERTXT$ = " hit the space bar to continue !          "
1330 GOSUB 1600: REM time display
1340 T$ = INKEY$: IF T$ = "" THEN GOTO 1330
1350 TIMERTXT$ = TEMPTEXT$
1360 NEXT I%
1370 GOTO 1090: REM START SCAN
1380 REM *** communications protocol *****
1390 FOR J = 1 TO 2000: REM waiting for acknowledge
1400 IF LOC(1) >= 3 THEN GOTO 1420
1410 NEXT J
1420 A$ = INPUT$(LOC(1), #1)
1430 IF INSTR(A$, ACK$) THEN GOTO 1480
1440 RETRY% = RETRY% + 1: REM if acknowledge is negative
1450 IF RETRY% <= 8 THEN GOTO 1490
1460 PRINT J; A$; " communications ERROR "; TIME$
1470 GOTO 1690: REM END
1480 RETRY% = 0: REM if acknowledge is positive
1490 RETURN
1500 REM *** measured values transmission *****
1510 mdata$ = "": C$ = INPUT$(LOC(1), #1)'clearing the input buffer of the PC
1520 PRINT #1, ENQ$; : REM request for data transmission
1530 FOR J = 1 TO 2000: REM waiting for data
1540 IF LOC(1) = 0 THEN GOTO 1570
1550 dtemp$ = INPUT$(LOC(1), #1): REM reading the characters
1560 mdata$ = mdata$ + dtemp$

```

```

1570 IF INSTR(mdata$, LF$) THEN GOTO 1590: REM message received
1580 NEXT J
1590 RETURN
1600 REM *** time display *****
1610 Y = CSRLIN: REM saves cursor position
1620 X = POS(0)
1630 LOCATE 25, 1: REM moves cursor to line 25, column 1
1640 PRINT TIMERTXT$;
1650 LOCATE 25, 47: REM moves cursor to line 25, column 47
1660 PRINT "BALZERS QMS422 "; TIME$; " soro";
1670 LOCATE Y, X: REM restores the old cursor position
1680 RETURN
1690 END

```

MID measurement with the RS-232-C interface (ASCII format)

```

10 REM *****
20 REM MIDQMS.BAS Multiple Ion Detection QMS 422 1.07.1997 soro
30 REM
40 REM Creation Date : 2.November 1996
50 REM Author : R. Sonderegger Abt. KARE
60 REM Version : V00.01
70 REM Modification :
80 REM Contents :
90 REM *****
100 CLS : ACK$ = CHR$(6): ENQ$ = CHR$(5): LF$ = CHR$(10): ETX$ = CHR$(3)
110 DATA middata(7),mass$(7)
120 MASS$(0) = "H2": MASS$(1) = "He": MASS$(2) = "CH4": MASS$(3) = "H2O":
130 MASS$(4) = "N2+CO": MASS$(5) = "O2": MASS$(6) = "Ar": MASS$(7) = "CO2":
140 REM ***<general>***<config>***<CTRL>*****
150 OPEN "COM1:19200,N,8,,CS,DS,CD" FOR RANDOM AS #1
160 REM opens COM1: with 19200 bps, no parity and eight data bits.
170 REM CTS, DSR and CD are not checked.
180 COM(1) ON: REM Aktiviert Ereignisverfolgung
190 ON COM(1) GOSUB 430
200 CBR% = 5: CMOACK% = 0: GOTO 260
210 OPEN "COM1:9600,N,8,,CS,DS,CD" FOR RANDOM AS #1: GOTO 260
220 OPEN "COM1:4800,N,8,,CS,DS,CD" FOR RANDOM AS #1: GOTO 260
230 OPEN "COM1:2400,N,8,,CS,DS,CD" FOR RANDOM AS #1: GOTO 260
240 OPEN "COM1:1200,N,8,,CS,DS,CD" FOR RANDOM AS #1: GOTO 260
250 OPEN "COM1:300,N,8,,CS,DS,CD" FOR RANDOM AS #1
260 PRINT #1, ETX$; : REM clearing the input buffer of the QMS422
270 PRINT #1, "CMO,1": REM send measurement data or parameters in ASCII strings
280 FOR J = 1 TO 4000: NEXT J' delay four seconds
290 IF CMOACK% = 128 THEN GOTO 400
300 CLOSE
310 IF CBR% = 0 THEN CBR% = 6
320 CBR% = CBR% - 1
330 IF CBR% = 4 THEN PRINT "check 9600 BAUD": GOTO 210
340 IF CBR% = 3 THEN PRINT "check 4800 BAUD": GOTO 220
350 IF CBR% = 2 THEN PRINT "check 2400 BAUD": GOTO 230
360 IF CBR% = 1 THEN PRINT "check 1200 BAUD": GOTO 240
370 IF CBR% = 0 THEN PRINT "check 300 BAUD": GOTO 250
380 CBR% = 5: PRINT "check 19200 BAUD"
390 GOTO 150
400 IF CBR% = 5 THEN GOTO 440
410 PRINT #1, "CBR,5": PRINT "send baud rates 19200 BAUD"
420 CLOSE : GOTO 150
430 CMOACK% = 128: RETURN
440 COM(1) OFF
450 C$ = INPUT$(LOC(1), #1): REM clearing the input buffer of the PC
460 PRINT "19200 BAUD"
470 REM ***<general>***<config>***<SYSTEM>*****
480 INPUT "defines the system configuration ? (Y/N)"; IN$
490 IF IN$ = "n" OR IN$ = "N" THEN GOTO 700
500 IF IN$ = "y" OR IN$ = "Y" THEN GOTO 520
510 GOTO 480
520 PRINT #1, "SQA": REM query for type of analyzer
530 GOSUB 1550: IF RETRY% > 0 THEN GOTO 520' communications protocol
540 PRINT #1, ENQ$; : REM request for data transmission
550 LINE INPUT #1, SQA$: REM reading the type of analyzer
560 IF SQA$ = "0" THEN GOTO 650
570 PRINT #1, "SQA,0": PRINT "SQA,0 type of analyzer QMA 125"
580 GOSUB 1550: IF RETRY% > 0 THEN GOTO 570' communications protocol
590 INPUT "mass range 200 (Y/N)"; IN$
600 SMR$ = "0": REM mass range 100
610 IF IN$ = "y" OR IN$ = "Y" THEN SMR$ = "1"
620 PRINT #1, "SMR," + SMR$
630 PRINT "SMR,"; SMR$; "QMA125 mass range 100 or 200"

```

```

640 GOSUB 1550: IF RETRY% > 0 THEN GOTO 620' communications protocol
650 INPUT "type of ion detection SEM (Y/N)"; IN$
660 SDT$ = "0": REM ion detection FARADAY
670 IF IN$ = "y" OR IN$ = "Y" THEN SDT$ = "1"
680 PRINT #1, "SDT," + SDT$: PRINT "SDT,"; SDT$; " ion detection SEM or FARADAY"
690 GOSUB 1550: IF RETRY% > 0 THEN GOTO 680' communications protocol
700 INPUT "vacuum <=10^4 mbar (Y/N)"; IN$
710 IF IN$ = "n" OR IN$ = "N" THEN GOTO 820
720 IF IN$ = "y" OR IN$ = "Y" THEN GOTO 740
730 GOTO 700
740 PRINT #1, "SEM,1": PRINT "SEM,1  enable the SEM high voltage"
750 GOSUB 1550: IF RETRY% > 0 THEN GOTO 740' communications protocol
760 PRINT #1, "FIE,1": PRINT "FIE,1  enable the emission"
770 GOSUB 1550: IF RETRY% > 0 THEN GOTO 760' communications protocol
780 PRINT #1, "TSI,0": PRINT "TSI,0  simulated test spectrum OFF"
790 GOSUB 1550: IF RETRY% > 0 THEN GOTO 780' communications protocol
800 TIMERTXT$ = " SAMPLE display measurement data as bargraph"
810 GOTO 850
820 PRINT #1, "TSI,1": PRINT "TSI,1  simulated test spectrum INTERN"
830 GOSUB 1550: IF RETRY% > 0 THEN GOTO 820' communications protocol
840 TIMERTXT$ = " SAMPLE !! simulated MID bargraph INTERN !! "
850 REM ***<operation>***<cycle>*****
860 PRINT #1, "CFU,0": PRINT "CFU,0  measurement operation CYCLE"
870 GOSUB 1550: IF RETRY% > 0 THEN GOTO 860' communications protocol
880 PRINT #1, "CYM,1": PRINT "CYM,1  cycle MULTI"
890 GOSUB 1550: IF RETRY% > 0 THEN GOTO 880' communications protocol
900 PRINT #1, "CYS,1": PRINT "CYS,1  number of measurement cycles"
910 GOSUB 1550: IF RETRY% > 0 THEN GOTO 900' communications protocol
920 PRINT #1, "CBE,0": PRINT "CBE,0  BEGIN "
930 GOSUB 1550: IF RETRY% > 0 THEN GOTO 930' communications protocol
940 PRINT #1, "CEN,7": PRINT "CEN,7  END"
950 GOSUB 1550: IF RETRY% > 0 THEN GOTO 940' communications protocol
960 REM ***<channels>*****
970 PRINT #1, "SDT": REM ion detection SEM or FARADAY
980 GOSUB 1550: IF RETRY% > 0 THEN GOTO 970' communications protocol
990 PRINT #1, ENQ$; : INPUT #1, SDT$' request for data transmission
1000 DATA 2,4,16,18,28,32,40,44
1010 RESTORE 1000: REM mass 2 ... 28 .... 44
1020 FOR I% = 0 TO 7
1030 PRINT #1, "SPC,"; I%: PRINT "SPC,"; I%; " selected parameter channel"
1040 GOSUB 1550: IF RETRY% > 0 THEN GOTO 1030' communications protocol
1050 PRINT #1, "DTY,"; SDT$: PRINT "DTY,"; SDT$; " ion detection SEM or FARADAY"
1060 GOSUB 1550: IF RETRY% > 0 THEN GOTO 1050' communications protocol
1070 PRINT #1, "MMO,3": PRINT "MMO,3  SAMPLE"
1080 GOSUB 1550: IF RETRY% > 0 THEN GOTO 1070' communications protocol
1090 PRINT #1, "MSD,7": PRINT "MSD,7  measurement speed per amu 100 ms"
1100 GOSUB 1550: IF RETRY% > 0 THEN GOTO 1090' communications protocol
1110 PRINT #1, "ARA,-5": PRINT "ARA,-5  electrometer range"
1120 GOSUB 1550: IF RETRY% > 0 THEN GOTO 1110' communications protocol
1130 PRINT #1, "AMO,2": PRINT "AMO,2  AUTO electrometer range"
1140 GOSUB 1550: IF RETRY% > 0 THEN GOTO 1130' communications protocol
1150 READ M%
1160 PRINT #1, "MFM,"; M%: PRINT "MFM,"; M%; "mass"
1170 GOSUB 1550: IF RETRY% > 0 THEN GOTO 1160' communications protocol
1180 NEXT I%
1190 CLS : C% = 0
1200 REM *** START MID *****
1210 PRINT #1, "CRU,2": LOCATE 1, 1: REM moves cursor to line 1, column 1
1220 C% = C% + 1
1230 PRINT USING "CRU,2 JOB-RUN ##### measurement cycles"; C%: PRINT
1240 GOSUB 1550: IF RETRY% > 0 THEN GOTO 1210' communications protocol
1250 GOSUB 1780: IF LOC(1) = 0 THEN GOTO 1250: REM time display
1260 LINE INPUT #1, ESQ$: REM waiting for measurement job completed
1270 PRINT #1, "MDB": REM query for measured data in scan operation
1280 GOSUB 1550: IF RETRY% > 0 THEN GOTO 1270' communications protocol
1290 REM *** reading the QMS422 measured values *****
1300 RESTORE 1000: REM mass 14 16 .... 44
1310 FOR I% = 0 TO 7' number of peak intensity
1320 GOSUB 1670: REM measured values transmission
1330 IF VAL(MDATA$) >= 1! OR VAL(MDATA$) = 0 THEN GOTO 1350
1340 MIDDATA(I%) = VAL(MDATA$): REM peak intensity
1350 REM *** display of measured values *****
1360 MIDSUM = 0
1370 FOR J% = 0 TO 7: MIDSUM = MIDSUM + MIDDATA(J%): NEXT J%
1380 INTPR = (MIDDATA(I%) * 100) / MIDSUM
1390 B$ = SPACE$(45)
1400 LSET B$ = STRING$(CINT(ABS(INTPR) / 2)), 219)
1410 READ M%
1420 PRINT USING "\      \:### ##.#####^ ^ ^ "; MASS$(I%); M%; MIDDATA(I%);
1430 PRINT B$; : PRINT USING "###.## %"; INTPR: PRINT
1440 GOSUB 1780: REM time display
1450 REM FOR J = 0 TO 100 NEXT J display delay 1/10 second
1460 REM *** press any key to stop the screen from scrolling *****

```

```

1470 T$ = INKEY$: IF T$ = "" THEN GOTO 1530
1480 TEMPTEXT$ = TIMERTXT$
1490 TIMERTXT$ = " hit the space bar to continue !           "
1500 GOSUB 1780: REM time display
1510 T$ = INKEY$: IF T$ = "" THEN GOTO 1500
1520 TIMERTXT$ = TEMPTEXT$
1530 NEXT I%
1540 GOTO 1200: REM START SCAN
1550 REM *** communications protocol *****
1560 FOR J = 1 TO 1000: REM waiting for acknowledge
1570 IF LOC(1) >= 3 THEN GOTO 1590
1580 NEXT J
1590 A$ = INPUT$(LOC(1), #1)
1600 IF INSTR(A$, ACK$) THEN GOTO 1650
1610 RETRY% = RETRY% + 1: REM if acknowledge is negative
1620 IF RETRY% <= 8 THEN GOTO 1660
1630 PRINT J; A$; " communications ERROR "; TIME$
1640 GOTO 1870: REM END
1650 RETRY% = 0: REM if acknowledge is positive
1660 RETURN
1670 REM *** measured values transmission *****
1680 GOSUB 1780: REM time display (wait "LF")
1690 MDATA$ = "": C$ = INPUT$(LOC(1), #1)'clearing the input buffer of the PC
1700 PRINT #1, ENQ$; : REM request for data transmission
1710 FOR J = 1 TO 2000: REM waiting for data
1720 IF LOC(1) = 0 THEN GOTO 1750
1730 DTEMP$ = INPUT$(LOC(1), #1): REM reading the characters
1740 MDATA$ = MDATA$ + DTEMP$
1750 IF INSTR(MDATA$, LF$) THEN GOTO 1770: REM message received
1760 NEXT J
1770 RETURN
1780 REM *** time display *****
1790 Y = CSRLIN: REM saves cursor position
1800 X = POS(0)
1810 LOCATE 25, 1: REM moves cursor to line 25, column 1
1820 PRINT TIMERTXT$;
1830 LOCATE 25, 47: REM moves cursor to line 25, column 47
1840 PRINT "BALZERS QMS422 "; TIME$; " soro";
1850 LOCATE Y, X: REM restores the old cursor position
1860 RETURN
1870 END

```

B Modifications with respect to the QMG 421

5.3 Mnemonics

- 1) This parameter is not available for the QMG 422.
 2) This parameter of the QMG 422 has changed with respect to the QMG 421.

5.3.1 <channels> group

Function	Parameter	Mnemonics	Page	Meaning
<select>	Measure-Ch	SMC	11	Selected measurement channel
	Parameter-Ch	SPC	11	Selected parameter channel
<detect>	TYPE	DTY	11	Signal source selection
	SEM	DSE	11	SEM high voltage for a channel
	QMU-CH	DAI ¹⁾	11	Analog input or Pirani channel number
	AI-CH / PI-CH	DAI ¹⁾		
	PHASE	DAI ¹⁾		
	LOCK-IN	DPC	11	Enable / disable the cold cathode measurement circuit
<mass>	MODE	MMO	12	Spectrum scan operation
	FIRST / MASS	MFM	12	First mass for a scan / mass number
	WIDTH	MWI	12	Width of a scan
	SPEED / DWELL	MSD	12	Measurement speed / measurement time
	RESOL	MRE	12	Resolution
	THRESH	MTH ²⁾	13	Peak processor threshold
	AVERAGE	MAV	13	Number of values used for averaging
	Steps	MST ²⁾	13	Measurement channel resolution (points per mass)
<amplif>	MODE	AMO	14	Measurement range switching mode
	RANGE	ARA ²⁾	14	Electrometer range, display range
	RANGE-L	ARL ²⁾	14	Narrowest measurement range for Auto Down
	GAIN	AGA	14	Post amplification factor
	FILTER	AFI	14	Analog filter setting
	OFFSET	AOF ²⁾	15	Offset correction for the electrometer
	CALIB	ACA	15	Calibration factor for the measured value
	P-CAL	APC	15	"Break" factor for changing the measurement channel in multichannel operation
	CP-LEV	ACL	15	Response threshold for the ion counter preamplifier
	AMP	ACL ¹⁾		
P-Time	APT		"Break" time for measurement channel switchover	
<aux>	STATE	AST	15	Enable measurement channel
	COPY TO CH	ACO	15	Copy the parameter set to channel xx
<output>	AO-CH	OAC	16	Analog output channel number
	AO-MODE	OMO	16	Analog output mode
	MONITOR	OAM ²⁾	16	Analog output monitor
	LOG-DEC	ODC	16	Logarithmic presentation at analog output
	O-RNG	ODC ¹⁾		
<trip>	TYPE	TTY	16	Type of switching function
	LEVEL-A	TLA	16	Switching function A / lower threshold for switching funct.
	LEVEL-B	TLB	16	Switching function B / upper threshold for switching funct.
	DO-A	TDA	16	Digital output bit number for switching function A
	DO-B	TDB	17	Digital output bit number for switching function B
<integ>	I-Chan	¹⁾		
	SETPT	¹⁾		
	DO-I	¹⁾		
	TRIG	¹⁾		
	Untergr	¹⁾		
	INTEG	¹⁾		

5.3.2 <general> group

Function	Parameter	Mnemonics	Page	Meaning
<di/do>	DIG-IN	DIS	17	Digital input status
	DIG-OUT	DOC	17	Digital output control
<config> SYSTEM	QMA	SQA ²⁾	17	Type of analyzer
	MASS-R	SMR	17	Type of mass range
	DETECT	SDT	17	Type of ion detector
	IS-TYP	SIT	18	Type of ion source
	OPTION	SOP ²⁾	18	System expansion information
<config> QMS-HW	QMS-HW	QHW	18	Pc boards in the QMS 422
<config> INIT	RESET	IRE	19	Parameter set (standard / user)
<config> CTRL	MODE	CMO	19	Select type of input
	BAUD	CBR	19	Transmission speed for the RS 232 C interface
	NODE	CNA	19	Node address for the LAN interface
	SEM+FIL	CSF	19	SEM and filament supply
<config> SIMUL	SIMUL	TSI	19	Simulated test spectrum
<config> TEST	QMS	TQM	20	RAM test, EPROM test, program number
	DSP	TDS	20	RAM test, EPROM test, program number
<error>	ERROR	ERR	20	Error message from QC 422
	Warning	EWN	20	Warning from QC 422
	State-QMS	ESQ	21	Control unit status (only interface)

5.3.3 <ion source> group

Function	Parameter	Mnemonics	Page	Meaning
<emiss>	EMISS	EMI	21	Emission current
	E-PROT	EPR	21	Max. filament current
<v1...v6>	V1 IONREF	V01	21	Ion source voltage 1
	V2 CATH	V02	21	Ion source voltage 2
	V3 FOCUS	V03	22	Ion source voltage 3
	V4 F-AXIS	V04	22	Ion source voltage 4
	V5 EXTRACT	V05	22	Ion source voltage 5
	V6 DEF-I	V06	22	Ion source voltage 6
<v7...>	V7	V07	22	Ion source voltage 7
	V8	V08	22	Ion source voltage 8
	V9 WEHNELT	V09	22	Ion source voltage 9
QMU-State	QMU 0...7	¹⁾		

5.3.4 <operation> group

Function	Parameter	Mnemonics	Page	Meaning
<sem hv>	SEM-VOLTAGE	SHV	22	Common SEM high voltage
<sem>	Control	SEM	23	Enable / disable the SEM high voltage
<ion src>	MODE	ISM	23	Type of ion source operation
	TYPE	ITY	23	Type of ion source
	FILAM	IFI	23	Filament change
	FIL1	IS1	23	Ion source set number for Filament 1
	FIL2	IS2	23	Ion source set number for Filament 2
	Emi-Disp	IED	23	Enable / disable the emission current display
	COPY	ICS	24	Copy the ion source set
	D-TIME	IDT	24	Duration of degas process
	D-EMIS	IDE	24	Emission current for degas
	D-PROT	IDP	24	Maximum filament current for degas
	CTRL	ISC	24	Enable / disable degas
<cycle>	FUNCT	CFU ²⁾	24	Measurement cycle operation
	MODE	CYM	24	Measurement cycle sequence
	CYCLES	CYS	24	Number of measurement cycles
	BEGIN	CBE	25	First channel in cycle
	END	CEN	25	Last channel in cycle
	TRIG	CTR	25	Measurement cycle control
	Run-Time	CWA	25	Scan time
	ADJ-TYP	CCF	25	Measurement cycle coarse / fine peak adjustment
<run / halt>	RUN / HALT	CRU	25	Start / Stop the measurement cycle
<filam>	Fila-Emi	FIE	25	Enable / disable the emission

5.3.5 Group of measured data not defined by a channel

Function	Parameter	Mnemonics	Page	Meaning
TOTAL	Pirani	TPI	26	Total pressure Pirani
	Penning	TPE	26	Total pressure cold cathode
ANALOG	A-Input	AIN	26	Analog input status
	A-Output	AOU	26	Analog output status
<trip> STATUS	T-State	TST	26	Switching function status
INTEGRATOR	I-Value	¹⁾		
	I-Time	¹⁾		
EMIS	EMI-CUR	ECU	27	Emission current display on the QME 125

5.3.6 Group of measured data defined by a channel

Function	Parameter	Mnemonics	Page	Meaning
MESSDATA	B-Counter	MBC	27	Contents counter for measured data buffer
	M-Counter			Number of measured values for this type of data
	M-State			Measurement is running / has finished
	M-Data Type			Type of data
	B-Header	MBH ²⁾	27	Measured data buffer header
	B-Data	MDB	27-30	Measured data buffer

6.4 Block identification

- 1) This parameter is not available for the QMG 422.
 2) This parameter of the QMG 422 has changed with respect to the QMG 421.
 3) This new parameter is only available for the QMG 422.

6.4.1 <channels> group

Frame	Parameter	Block identification	Page	Meaning
<select>	Measure-Ch	01 / 02	39	Selected measurement channel
	Parameter-Ch	03 / 04	39	Selected parameter channel
<detect>	TYPE	05 / 06	39	Signal source selection
	SEM			SEM high voltage for a channel
	QMU-CH	1)		
	AI-CH / PI-CH	1)		Analog input or Pirani channel number
	PHASE	1)		
	LOCK-IN	1)		
	PE-CTRL	103 / 104	40, 56	Enable / disable the cold cathode measurement circuit
<mass>	MODE	07 / 08	41	Spectrum scan operation
	FIRST / MASS			First mass for a scan / mass number
	WIDTH			Width of a scan
	SPEED / DWELL			Measurement speed / measurement time
	RESOL			Resolution
	THRESH	2)		Peak processor threshold
	AVERAGE	2)		Number of values used for averaging
	Steps		Measurement channel resolution (points per mass)	
<amplif>	MODE	11 / 12 2)	42	Measurement range switching mode
	RANGE	2)		Electrometer range
	RANGE-L	2)		Narrowest measurement range for Auto Down
	GAIN			Post amplification factor
	FILTER			Analog filter setting
	OFFSET	1)		
	CALIB			Calibration factor for the measured value
	P-CAL			"Break" factor for changing the measurement channel in multichannel operation
	CP-LEV			Response threshold for the ion counter preamplifier
	AMP	1)		
	P-Time	69 / 70	43	"Break" time for measurement channel switchover
<aux>	STATE	13 / 14	43	Enable measurement channel
	COPY TO CH	16	43	Copy the parameter set to channel xx
<output>	AO-CH	17 / 18	44	Analog output channel number
	AO-MODE			Analog output mode
	MONITOR	2)		Analog output monitor
	LOG-DEC	2)		Logarithmic presentation at analog output
	O-RNG			Display range for ion counting operation
<trip>	TYPE	19 / 20	44	Type of switching function
	LEVEL-A			Switching function A / lower threshold for switching funct.
	LEVEL-B			Switching function B / upper threshold for switching funct.
	DO-A			Digital output bit number for switching function A
	DO-B			Digital output bit number for switching function B
<integ>	I-Chan		1)	
	SETPT		1)	
	DO-I		1)	
	TRIG		1)	
	Untergr		1)	
	INTEG		1)	

6.4.2 <general> group

Frame	Parameter	Block identification	Page	Meaning
<di/do>	DIG-IN	23 / 24	45	Digital input status (block operation)
		25 / 26	45	" (single bit operation)
	DIG-OUT	27 / 28	46	Digital output control (block operation)
		29 / 30	46	" (single bit operation)
<config> SYSTEM	QMA MASS-R DETECT IS-TYP OPTION	31 / 32 ²⁾	47	Type of analyzer Type of RF generator Type of ion detector Type of ion source System expansion information
<config> QMS-HW	QMS-HW	33 / 34	47	Pc boards in the QMS 422
<config> INIT	RESET	36	48	Parameter set (standard / user)
<config> CTRL	MODE	37 / 38	48	Select type of input
	BAUD			Transmission speed for the RS 232 C interface
	NODE			Node address for the LAN interface
	SEM+FIL			SEM and filament supply
<config> SIMUL	SIMUL	71 / 72	48	Simulated test spectrum
<config> TEST	QMS	39 / 40	49	RAM test, EPROM test, program number
	DSP			RAM test, EPROM test, program number
<error> STATUS	ERROR Warning State-QMS State-QMU	41 / 42	50	Error message from QC 422 Warning from QC 422 Control unit status (only interface)

6.4.3 <ion source> group

Frame	Parameter	Block identification	Page	Meaning
<emiss>	EMISS E-PROT	43 / 44	51	Emission current Max. filament current
<v1...v6>	V1 IONREF V2 CATH V3 FOCUS V4 F-AXIS V5 EXTRACT V6 DEF-I	45 / 46	51	Ion source voltage 1
				Ion source voltage 2
				Ion source voltage 3
				Ion source voltage 4
				Ion source voltage 5
				Ion source voltage 6
<v7...>	V7 V8 V9 WEHNELT			Ion source voltage 7 Ion source voltage 8 Ion source voltage 9
QMU-State	QMU 0...7	¹⁾		

6.4.4 <operation> group

Frame	Parameter	Block identification	Page	Meaning
<sem hv> <sem>	SEM-VOLTAGE Control	49 / 50	52	Common SEM high voltage Enable / disable the SEM high voltage
<ion src>	MODE TYPE FILAM FIL1 FIL2 Emi-Disp COPY D-TIME D-EMIS D-PROT CTRL	51 / 52 53 / 54 55 / 56 57 / 58	52 53 53 53	Type of ion source operation Type of ion source Filament change Ion source set number for Filament 1 Ion source set number for Filament 2 Enable / disable the emission current display Copy the ion source set Duration of degas process Emission current for degas Maximum filament current for degas Enable / disable degas
<cycle>	FUNCT MODE CYCLES BEGIN END TRIG Run-Time ADJ-TYP	59 / 60 ²⁾ 61 / 62 63 / 64	54 54 54	Measurement cycle operation Measurement cycle sequence Number of measurement cycles First channel in cycle Last channel in cycle Measurement cycle control Scan time Measurement cycle Coarse / fine peak adjustment
<run / halt>	RUN / HALT	65 / 66	55	Start / Stop the measurement cycle
<filam>	Fila-Emi	67 / 68	55	Enable / disable the emission

6.4.5 Group of measured data not defined by a channel

Frame	Parameter	Block identification	Page	Meaning
TOTAL	Pirani Penning	101 / 102 103 / 104	56 56, 40	Total pressure Pirani Total pressure cold cathode
ANALOG	A-Input A-Output	105 / 106 107 / 108	57 57	Analog input status Analog output status
<trip> STATUS	T-State	109 / 110 111 / 112	58 58	Switching function status (block operation) " (single bit operation)
INTEGRATOR	I-Value I-Time	¹⁾ ¹⁾		
EMIS	EMI-CUR	113 / 114	59	Emission current display on the QME 125
Offset-Value		119 / 120 ³⁾	59	

6.4.6 Group of measured data defined by a channel

Frame	Parameter	Block identification	Page	Meaning
MESSDATA	B-Counter M-Counter M-State M-Data Type B-Header B-Data	131 / 132 133 / 134	60 61-69	Contents counter for measured data buffer Number of measured values for this type of data Measurement is running / has finished Type of data Measured data buffer header Measured data buffer

