

DAQ

DAQ Hardware Overview Guide

October 1998 Edition
Part Number 321646D-01

Internet Support

E-mail: support@natinst.com

FTP Site: <ftp.natinst.com>

Web Address: <http://www.natinst.com>

Bulletin Board Support

BBS United States: 512 794 5422

BBS United Kingdom: 01635 551422

BBS France: 01 48 65 15 59

Fax-on-Demand Support

512 418 1111

Telephone Support (USA)

Tel: 512 795 8248

Fax: 512 794 5678

International Offices

Australia 03 9879 5166, Austria 0662 45 79 90 0, Belgium 02 757 00 20, Brazil 011 288 3336,
Canada (Ontario) 905 785 0085, Canada (Québec) 514 694 8521, Denmark 45 76 26 00,
Finland 09 725 725 11, France 01 48 14 24 24, Germany 089 741 31 30, Hong Kong 2645 3186,
Israel 03 6120092, Italy 02 413091, Japan 03 5472 2970, Korea 02 596 7456, Mexico 5 520 2635,
Netherlands 0348 433466, Norway 32 84 84 00, Singapore 2265886, Spain 91 640 0085, Sweden 08 730 49 70,
Switzerland 056 200 51 51, Taiwan 02 377 1200, United Kingdom 01635 523545

National Instruments Corporate Headquarters

6504 Bridge Point Parkway Austin, Texas 78730-5039 USA Tel: 512 794 0100

Important Information

Warranty

DAQ hardware is warranted against defects in materials and workmanship for a period of one year from the date of shipment, as evidenced by receipts or other documentation. National Instruments will, at its option, repair or replace equipment that proves to be defective during the warranty period. This warranty includes parts and labor.

The media on which you receive National Instruments software are warranted not to fail to execute programming instructions, due to defects in materials and workmanship, for a period of 90 days from date of shipment, as evidenced by receipts or other documentation. National Instruments will, at its option, repair or replace software media that do not execute programming instructions if National Instruments receives notice of such defects during the warranty period. National Instruments does not warrant that the operation of the software shall be uninterrupted or error free.

A Return Material Authorization (RMA) number must be obtained from the factory and clearly marked on the outside of the package before any equipment will be accepted for warranty work. National Instruments will pay the shipping costs of returning to the owner parts which are covered by warranty.

National Instruments believes that the information in this manual is accurate. The document has been carefully reviewed for technical accuracy. In the event that technical or typographical errors exist, National Instruments reserves the right to make changes to subsequent editions of this document without prior notice to holders of this edition. The reader should consult National Instruments if errors are suspected. In no event shall National Instruments be liable for any damages arising out of or related to this document or the information contained in it.

EXCEPT AS SPECIFIED HEREIN, NATIONAL INSTRUMENTS MAKES NO WARRANTIES, EXPRESS OR IMPLIED, AND SPECIFICALLY DISCLAIMS ANY WARRANTY OF MERCHANTABILITY OR FITNESS FOR A PARTICULAR PURPOSE. CUSTOMER'S RIGHT TO RECOVER DAMAGES CAUSED BY FAULT OR NEGLIGENCE ON THE PART OF NATIONAL INSTRUMENTS SHALL BE LIMITED TO THE AMOUNT THERETOFORE PAID BY THE CUSTOMER. NATIONAL INSTRUMENTS WILL NOT BE LIABLE FOR DAMAGES RESULTING FROM LOSS OF DATA, PROFITS, USE OF PRODUCTS, OR INCIDENTAL OR CONSEQUENTIAL DAMAGES, EVEN IF ADVISED OF THE POSSIBILITY THEREOF. This limitation of the liability of National Instruments will apply regardless of the form of action, whether in contract or tort, including negligence. Any action against National Instruments must be brought within one year after the cause of action accrues. National Instruments shall not be liable for any delay in performance due to causes beyond its reasonable control. The warranty provided herein does not cover damages, defects, malfunctions, or service failures caused by owner's failure to follow the National Instruments installation, operation, or maintenance instructions; owner's modification of the product; owner's abuse, misuse, or negligent acts; and power failure or surges, fire, flood, accident, actions of third parties, or other events outside reasonable control.

Copyright

Under the copyright laws, this publication may not be reproduced or transmitted in any form, electronic or mechanical, including photocopying, recording, storing in an information retrieval system, or translating, in whole or in part, without the prior written consent of National Instruments Corporation.

Trademarks

CVI™, DAQCard™, DAQpad™, DAQ-PnP™, DAQ-STC™, LabVIEW™, National Instruments™, natinst.com™, NI-DAQ™, NI-DSP™, NI-PGIA™, RTSI™, SCXI™, and VirtualBench™, are trademarks of National Instruments Corporation.

Product and company names referenced in this document are trademarks or trade names of their respective companies.

WARNING REGARDING MEDICAL AND CLINICAL USE OF NATIONAL INSTRUMENTS PRODUCTS

National Instruments products are not designed with components and testing intended to ensure a level of reliability suitable for use in treatment and diagnosis of humans. Applications of National Instruments products involving medical or clinical treatment can create a potential for accidental injury caused by product failure, or by errors on the part of the user or application designer. Any use or application of National Instruments products for or involving medical or clinical treatment must be performed by properly trained and qualified medical personnel, and all traditional medical safeguards, equipment, and procedures that are appropriate in the particular situation to prevent serious injury or death should always continue to be used when National Instruments products are being used. National Instruments products are NOT intended to be a substitute for any form of established process, procedure, or equipment used to monitor or safeguard human health and safety in medical or clinical treatment.

About This Guide

Organization of This Guide	xiii
Conventions Used in This Guide	xv
MIO and AI Device Terminology	xviii
Related Documentation.....	xx
Customer Communication	xx

Chapter 1

MIO and AI Devices

MIO and AI Multifunction I/O Devices	1-1
MIO and AI Device Analog Input.....	1-1
E Series Data Acquisition	1-3
E Series Data Acquisition Timing.....	1-5
E Series DAQ Rates	1-7
MIO Device Analog Output	1-7
MIO Device Waveform Generation.....	1-8
E Series Waveform Generation Using Onboard Memory	1-8
E Series Digital I/O	1-9
E Series Counter/Timer Operation	1-10
E Series Programmable Frequency Output Operation	1-10
E Series PFI Pins.....	1-10

Chapter 2

Lab and 1200 Devices

Lab and 1200 Devices Analog Input	2-1
Lab and 1200 Devices Data Acquisition	2-2
Lab and 1200 Devices Data Acquisition Timing.....	2-4
Lab and 1200 Devices Data Acquisition Rates.....	2-5
Lab and 1200 Devices Analog Output.....	2-6
Lab and 1200 Devices Waveform Generation	2-6
Lab and 1200 Devices Digital I/O	2-6
Lab and 1200 Devices Groups	2-7
Lab and 1200 Devices Interval Counter/Timer Operation	2-7
Lab and 1200 Devices Counter/Timers.....	2-8

1200 Device Acquisition Rate.....	2-9
DAQPad-1200 Printer Connection.....	2-9
1200 Device Calibration.....	2-9

Chapter 3

LPM Devices

LPM Device Analog Input	3-1
LPM Device Data Acquisition.....	3-1
LPM Device Data Acquisition Timing.....	3-2
LPM Device Data Acquisition Rates.....	3-3
LPM Device Digital I/O	3-3
LPM Device Interval Counter/Timer Operation	3-3
LPM Device Counter/Timers	3-4

Chapter 4

516 Devices and DAQCard-500/700 Devices

516 Devices and DAQCard-500/700 Analog Input	4-1
516 Devices and DAQCard-500/700 Data Acquisition.....	4-2
516 Devices and DAQCard-500/700 Data Acquisition Timing.....	4-2
516 Devices and DAQCard-500/700 Digital I/O	4-3
516 Devices and DAQCard-500/700 Interval Counter/Timer Operation	4-4
DAQCard-700 Counter/Timers.....	4-4
516 Devices and DAQCard-500 Counter/Timers	4-5

Chapter 5

AT-AO-6/10 Analog Output Boards

AT-AO-6/10 Analog Output	5-1
AT-AO-6/10 Waveform Generation.....	5-1
Waveform Generation Using Onboard Memory	5-1
Hardware Restrictions for the AT-AO-6/10	5-2
AT-AO-6/10 Digital I/O.....	5-3

Chapter 6

6704 Devices

PCI-6704 and PXI-6704 Analog Output Boards.....	6-1
PCI-6704 and PXI-6704 Digital I/O	6-1

Chapter 7**PC-TIO-10 Timing I/O Board**

PC-TIO-10 Counter/Timer Operation	7-1
Am9513-Based Device Counter/Timer Operation	7-1
Programmable Frequency Output Operation	7-4
PC-TIO-10 Counter/Timers.....	7-5
PC-TIO-10 Digital I/O.....	7-5

Chapter 8**DIO-96 Digital I/O Boards**

DIO-96 Digital I/O.....	8-1
DIO-96 Groups.....	8-3

Chapter 9**DIO-24, AT-MIO-16DE-10, and 6025E Devices**

DIO-24, AT-MIO-16DE-10, and 6025E Digital I/O	9-1
DIO-24, AT-MIO-16DE-10, and 6025E Device Groups	9-2

Chapter 10**DIO-32F and DAQDIO 6533 (DIO-32HS) Digital I/O Devices**

DIO-32F and DAQDIO 6533 (DIO-32HS) Digital I/O Boards	10-1
---	------

Chapter 11**AMUX-64T External Multiplexer Device**

AMUX-64T External Multiplexer Device.....	11-1
Scanning Order Using the AMUX-64T	11-2

Chapter 12**SC-204X Devices**

SC-2040 Track-and-Hold Accessory.....	12-1
SC-2042-RTD Accessory	12-2
SC-2043-SG Accessory	12-2

Chapter 13**SCC Series Devices**

SCC Shielded Carrier.....	13-1
SCC Series Components.....	13-2
SCC-A10 Voltage Attenuator Module.....	13-2

SCC-CI20 Current Input Module.....	13-2
SCC-TC01/02 Thermocouple Input Modules.....	13-2
SCC-FT01 Feed-Through/Breadboard Module	13-3
SCC Configuration	13-3

Chapter 14

SCXI Hardware

SCXI Installation and Configuration.....	14-2
SCXI Operating Modes	14-2
Multiplexed Mode for Analog Input Modules	14-2
Multiplexed Mode for the SCXI-1200.....	14-3
Multiplexed Mode for Analog Output Modules	14-4
Multiplexed Mode for Digital and Relay Modules	14-4
Parallel Mode for Analog Input Modules	14-4
Parallel (or Standalone) Mode for the SCXI-1200	14-5
Parallel Mode for Digital Modules	14-5
SCXI Modules and Compatible DAQ Devices	14-6
SCXI-1100	14-6
SCXI-1101	14-7
SCXI-1102	14-7
SCXI-1102B and the SCXI-1102C.....	14-8
SCXI-1120, SCXI-1120D, and SCXI-1121	14-8
SCXI-1122	14-9
SCXI-1124	14-10
SCXI-1126	14-11
SCXI-1140	14-12
SCXI-1141	14-13
SCXI-1160 and SCXI-1161	14-14
SCXI-1162 and SCXI-1162HV	14-14
SCXI-1163 and SCXI-1163R	14-15
SCXI-1200	14-16
MIO and AI DAQ Devices (except Parallel Ports).....	14-17
Lab and 1200 Devices (except Parallel Ports)	14-19
DIO-24 and the DIO-96	14-20
DIO-32F and DAQDIO 6533 Device (DIO-32HS).....	14-21

Chapter 15

VXI-DAQ Devices

RTSI	15-1
VXI-DIO-128 Digital I/O Board	15-2
VXI-AO-48XDC Analog Output Board	15-2
VXI-AO-48XDC Digital I/O	15-3

VXI-DAQ Signal Conditioning	15-3
VXI-SC-1102 Submodule	15-4
VXI-SC-1102B and the VXI-SC-1102C Submodules	15-4
VXI-SC-1150 Submodule	15-4

Chapter 16

PXI DAQ Devices

RTSI.....	16-1
PXI DAQ Signal Conditioning	16-2

Chapter 17

NI 5411 Devices

NI 5411 Arbitrary Waveform and Pattern Generator Devices	17-1
NI 5411 Device Characteristics	17-1
NI 5411 Device Waveform Generation	17-3
DDS Mode.....	17-3
NI 5411 Device Waveform Pattern Generation.....	17-4
NI 5411 Device Pattern Generation Timing	17-4
NI 5411 Device Waveform Generation Triggering	17-5
NI 5411 Device Feature Settings	17-6

Chapter 18

NI 435X Devices

NI 435X Device Analog Input	18-1
NI 435X Data Acquisition.....	18-2
NI 435X Acquisition Timing	18-3
NI 435X Current Source	18-4
NI 435X Digital I/O	18-4

Chapter 19

NI 40XX Devices

NI 40XX Device Input.....	19-1
NI 40XX Data Acquisition	19-2
NI 40XX Data Acquisition Filtering and Timing.....	19-2

Chapter 20

DSA Devices

PCI-445X and PCI-455X Devices.....	20-1
PCI-445X and PCI-455X Analog Input Channels.....	20-1
Data Acquisition.....	20-2

Data Acquisition Timing	20-3
PCI-4451 and PCI-4551 Analog Output Channels	20-4
Waveform Generation.....	20-4
PCI-445X and PCI-455X Digital I/O	20-5
PCI-445X Digital I/O	20-5
PCI-455X Digital I/O	20-5
PCI-445X and PCI-455X Counter/Timer Operation.....	20-6
PCI-445X Counter/Timers	20-6
PCI-455X Counter/Timers	20-6

Chapter 21

671X Devices

671X Device Analog Output	21-1
671X Device Waveform Generation	21-1
671X Waveform Generation Using Onboard Memory	21-2
671X Digital I/O	21-2
671X Counter/Timer Operation.....	21-3
671X Programmable Frequency Output Operation	21-3
671X PFI Pins	21-3

Customer Communication

Glossary

Index

Figures

Figure 2-1. Lab and 1200 Device Interval Counter Block Diagram	2-7
Figure 2-2. Lab and 1200 Devices Counter/Timer Signal Connections.....	2-8
Figure 3-1. LPM Device Counter/Timer Signal Connections	3-4
Figure 4-1. 516 Devices and DAQCard-500/700 Counter/Timer Signal Connections	4-5
Figure 7-1. Counter Block Diagram	7-1
Figure 7-2. Am9513 Counter Timing and Output Types	7-4
Figure 17-1. Examples of Waveform Generation.....	17-3

Tables

Table 1.	MIO and AI Device Classification	xviii
Table 1-1.	MIO and AI Multifunction I/O Device Analog Input Characteristics ...	1-1
Table 1-2.	AT-MIO-16DE-10 and 6025E Device Ports	1-10
Table 2-1.	Lab and 1200 Devices and Corresponding FIFO Size	2-2
Table 2-2.	Typical Settling Accuracies for Maximum Multiple-Channel Scanning Rates for the Lab and 1200 Devices	2-5
Table 3-1.	Maximum Recommended Data Acquisition Rates for the LPM Devices	3-3
Table 8-1.	DIO-96 Port Labels, Numbers, and Modes	8-1
Table 9-1.	Digital I/O Device Port Numbers	9-1
Table 10-1.	DIO-32F Extra Inputs and Outputs	10-2
Table 10-2.	DAQDIO 6533 (DIO-32HS) Extra Inputs and Outputs	10-3
Table 11-1.	Analog Input Channel Range	11-1
Table 11-2.	AMUX-64T Channel Numbers	11-2
Table 11-3.	AMUX-64T Scanning Order for Each MIO or AI Device Input Channel	11-3
Table 15-1.	RTSI Bus Line and VXIbus Trigger Mapping	15-1
Table 16-1.	RTSI Bus Line and PXI Bus Trigger Mapping	16-1
Table 17-1.	NI 5411 Device Characteristics	17-1
Table 17-2.	NI 5411 Operational Modes	17-5
Table 18-1.	Analog Input Ranges for the 435X Devices	18-2
Table 18-2.	Ranges for 435X Device Data Acquisition	18-2
Table 18-3.	Relationship between Filtering and Available Sample Rates	18-3
Table 19-1.	Relationship between Notch Filter Frequency and Power Line Frequencies Filtered	19-2
Table 19-2.	Relationship between Notch Filter Frequency and Single-Channel Acquisition Rate	19-3
Table 19-3.	Relationship between Notch Filter Frequency and Single-Channel Acquisition Rate when AutoZero Is Enabled	19-3
Table 20-1.	PCI-445X and PCI-455X Hardware Features	20-1

The *DAQ Hardware Overview Guide* is for users of the NI-DAQ software for PC compatibles version 6.5. NI-DAQ software is a powerful application programming interface (API) between your data acquisition (DAQ) application and your National Instruments DAQ devices.

Organization of This Guide

The *DAQ Hardware Overview Guide* is organized as follows:

- Chapter 1, *MIO and AI Devices*, contains overview information on the MIO and AI devices.
- Chapter 2, *Lab and 1200 Devices*, contains overview information on the DAQCard-1200, DAQPad-1200, Lab-PC+, Lab-PC-1200, Lab-PC-1200AI, PCI-1200, and SCXI-1200 devices.
- Chapter 3, *LPM Devices*, contains overview information on the PC-LPM-16 and PC-LPM-16PnP.
- Chapter 4, *516 Devices and DAQCard-500/700 Devices*, contains overview information on the DAQCard-500, DAQCard-516, DAQCard-700, and PC-516.
- Chapter 5, *AT-AO-6/10 Analog Output Boards*, contains overview information on the AT-AO-6/10 analog output boards, including the AT-AO-6 and the AT-AO-10.
- Chapter 6, *6704 Devices*, contains overview information on the PCI-6704 and PXI-6704 analog output boards.
- Chapter 7, *PC-TIO-10 Timing I/O Board*, contains overview information on the PC-TIO-10 timing I/O board.
- Chapter 8, *DIO-96 Digital I/O Boards*, contains overview information on the DIO-96 digital I/O boards, including the PC-DIO-96, PC-DIO-96PnP, PCI-DIO-96, DAQPad-6507, DAQPad-6508, and the PXI-6508.
- Chapter 9, *DIO-24, AT-MIO-16DE-10, and 6025E Devices*, contains overview information on the DIO-24 (PC-DIO-24,

PC-DIO-24PnP, and DAQCard-DIO-24), AT-MIO-16D, and AT-MIO-16DE-10 digital I/O devices.

- Chapter 10, *DIO-32F and DAQDIO 6533 (DIO-32HS) Digital I/O Devices*, contains overview information on the DIO-32F and DAQDIO 6533 (DIO-32HS) digital I/O devices, including the AT-DIO-32F, AT-DIO-32HS, PCI-DIO-32HS, DAQCard-6533, DAQPad-6533, and PXI-6533.
- Chapter 11, *AMUX-64T External Multiplexer Device*, contains overview information on the AMUX-64T device.
- Chapter 12, *SC-204X Devices*, contains overview information on the SC-2040, SC-2042-RTD, and SC-2043-SG.
- Chapter 13, *SCC Series Devices*, contains overview information on SCC devices.
- Chapter 14, *SCXI Hardware*, contains overview information on SCXI hardware.
- Chapter 15, *VXI-DAQ Devices*, contains overview information on VXI-DAQ devices, including the VXI-DIO-128, VXI-AO-48XDC, VXI-SC-1102, VXI-SC-1102B, VXI-SC-1102C, VXI-SC-1150, VXI-MIO-64E-1, and VXI-MIO-64XE-10.
- Chapter 16, *PXI DAQ Devices*, contains overview information on PXI DAQ hardware.
- Chapter 17, *NI 5411 Devices*, contains overview information on the NI 5411 and arbitrary waveform generator devices for ISA and PCI.
- Chapter 18, *NI 435X Devices*, contains overview information on the NI 435X devices, including the NI 4350 for ISA, PCMCIA, USB, PCI and PXI.
- Chapter 19, *NI 40XX Devices*, contains overview information on the NI 40XX devices, including the NI 4050 and NI 4060 instruments.
- Chapter 20, *DSA Devices*, contains overview information on the DSA PCI-4451, PCI-4452, PCI-4551, and PCI-4552 devices.
- Chapter 21, *671X Devices*, contains overview information on the PCI-671X devices, including the PCI-6711, PCI-6713, PXI-6711, PXI-6713, and DAQPad-6713.
- The *Customer Communication* appendix contains forms you can use to request help from National Instruments or to comment on our products and manuals.

- The *Glossary* contains an alphabetical list and description of terms used in this guide, including abbreviations, acronyms, definitions, metric prefixes, mnemonics, and symbols.
- The *Index* contains an alphabetical list of key terms and topics in this manual, including the page where you can find each one.

Conventions Used in This Guide

	The following conventions are used in this guide.
	This icon to the left of bold italicized text denotes a note, which alerts you to important information.
bold	Bold text denotes the names of menus, menu items, parameters, dialog boxes, dialog box buttons or options, icons, windows, Windows 95 tabs or pages, or LEDs.
<i>bold italic</i>	Bold italic text denotes a note, caution, or warning.
<i>italic</i>	Italic text denotes emphasis, a cross reference, or an introduction to a key concept. This font also denotes text for which you supply the appropriate word or value, such as in NI-DAQ 5.x.
monospace	Text in this font denotes text or characters that you should literally enter from the keyboard, sections of code, programming examples, and syntax examples. This font also is used for the proper names of disk drives, paths, directories, programs, subprograms, subroutines, device names, functions, operations, variables, filenames, and extensions, and for statements and comments taken from program code.
<i>monospace italic</i>	Italic text in this font denotes that you must supply the appropriate words or values in the place of these items.
1102/B/C modules	Refers to the SCXI-1102, SCXI-1102B, and SCXI-1102C modules and the VXI-SC-1102, VXI-SC-1102B, and VXI-SC-1102C submodules.
12-bit device	These MIO and AI devices are listed in Table 1.
16-bit device	These MIO and AI devices are listed in Table 1.
1394	Refers to a high-speed external bus that implements the IEEE 1394 serial bus protocol.

435X device	Refers to the NI 4350 for ISA, PCMCIA, USB, and NI 4351 for PCI and PXI.
445X device	Refers to the PCI-4451 and PCI-4452.
455X device	Refers to the PCI-4551 and PCI-4552.
516 device	Refers to the DAQCard-516 and PC-516.
6025E device	Refers to the PCI-6025E and PXI-6025E.
6052E device	Refers to the PCI-6052E, PXI-6052E, and DAQPad-6052E for 1394.
611X device	Refers to the PCI-6110E and PCI-6111E.
6602 device	Refers to the PCI-6602 and PXI-6602.
6704 device	Refers to the PCI-6704 and PXI-6704.
671X device	Refers to the PCI-6711, PXI-6711, PCI-6713, PXI-6713, and DAQPad-6713.
AI device	These analog input devices are listed in Table 1.
DAQCard-500/700	Refers to the DAQCard-500 and DAQCard-700.
DIO 6533	Refers to the AT-DIO-32HS, PCI-DIO-32HS, DAQCard-6533, and PXI-6533.
DIO-24	Refers to the PC-DIO-24, PC-DIO-24PnP, and DAQCard-DIO-24.
DIO-32F	Refers to the AT-DIO-32F.
DIO-96	Refers to the PC-DIO-96, PC-DIO-96PnP, PCI-DIO-96, DAQPad-6507, DAQPad-6508, and PXI-6508.
DIO device	Refers to any DIO-24, DIO-32, DIO-6533, or DIO-96.
DSA device	Refers to the PCI-4451, PCI-4452, PCI-4551, and PCI-4552.
E Series device	These are MIO and AI devices. Refer to Table 1 for a complete list of these devices.
1200 and 1200AI device	Refers to the DAQCard-1200, DAQPad-1200, Lab-PC-1200, Lab-PC-1200AI, PCI-1200, and SCXI-1200.

Lab and 1200 device	Refers to the DAQCard-1200, DAQPad-1200, Lab-PC+, Lab-PC-1200, Lab-PC-1200AI, PCI-1200, and SCXI-1200.
Lab and 1200 analog output device	Refers to the DAQCard-1200, DAQPad-1200, Lab-PC+, Lab-PC-1200, PCI-1200, and SCXI-1200.
LPM device	Refers to the PC-LPM-16 and PC-LPM-16PnP.
MIO device	Refers to multifunction I/O devices. See Table 1 for a list of these devices.
MIO-16XE-50 device	Refers to the AT-MIO-16XE-50, DAQPad-MIO-16XE-50, and NEC-MIO-16XE-50, and PCI-MIO-16XE-50.
MIO-64	Refers to the AT-MIO-64E-4, PCI-6031E, PCI-6071E, VXI-MIO-64E-1, and VXI-MIO-64XE-10.
NI 40XX device	Refers to the NI 4050 for PCMCIA, and NI 4060 for ISA, PCI, PXI, and USB.
NI 5411 device	Refers to the NI 5411 for ISA and PCI.
NI-DAQ	Refers to the NI-DAQ software for PC compatibles, unless otherwise noted.
NI-TIO based device	Refers to the PCI-4551, PCI-4552, PCI-6602, and PXI-6602.
PC	Refers to the IBM PC/XT, IBM PC AT, and compatible computers.
PCI Series	Refers to the National Instruments products that use the high-performance expansion bus architecture originally developed by Intel to replace ISA and EISA.
Remote SCXI	Refers to an SCXI configuration where either an SCXI-2000 chassis or an SCXI-2400 remote communications module is connected to the PC serial port.
SCXI-1102/B/C	SCXI-1102/B/C refers to the SCXI-1102, SCXI-1102B, and SCXI-1102C devices.
SCXI-1120/D	SCXI-1120/D refers to the SCXI-1120 and SCXI-1120D.
SCXI analog input module	Refers to the SCXI-1100, SCXI-1102, SCXI-1120, SCXI-1120D, SCXI-1121, SCXI-1122, SCXI-1140, and SCXI-1141.
SCXI chassis	Refers to the SCXI-1000, SCXI-1000DC, SCXI-1001, and SCXI-2000.

SCXI communication module	Refers to the SCXI-2400.
SCXI DAQ module	Refers to the SCXI-1200.
SCXI digital module	Refers to the SCXI-1160, SCXI-1161, SCXI-1162, SCXI-1162HV, SCXI-1163, and SCXI-1163R.
Simultaneous sampling device	Refers to the PCI-6110E, PCI-6111E, PCI-4451, PCI-4452, PCI-4551, and PCI-4552.
VXI-MIO device	Refers to the VXI-MIO-64E-1 and VXI-MIO-64XE-10.
VXI-SC-1102/B/C	Refers to the VXI-SC-1102, VXI-SC-1102B, and VXI-SC-1102C. The following conventions are used in this guide.

MIO and AI Device Terminology

This guide uses generic terms to describe groups of devices whenever possible. The generic terms for the MIO and AI devices are based on the number of bits, the platform, and the functionality. These devices are also collectively known as E Series devices. The following table lists each MIO and AI device and the possible classifications for each.

Table 1. MIO and AI Device Classification

Device	Number of SE Channels	Bit	Type	Functionality
AT-AI-16XE-10	16	16-bit	AT	AI
AT-MIO-16DE-10	16	12-bit	AT	MIO
AT-MIO-16E-1	16	12-bit	AT	MIO
AT-MIO-16E-2	16	12-bit	AT	MIO
AT-MIO-16E-10	16	12-bit	AT	MIO
AT-MIO-16XE-10	16	16-bit	AT	MIO
AT-MIO-16XE-50	16	16-bit	AT	MIO
AT-MIO-64E-3	64	12-bit	AT	MIO
DAQCard-AI-16E-4	16	12-bit	PCMCIA	AI

Table 1. MIO and AI Device Classification (Continued)

Device	Number of SE Channels	Bit	Type	Functionality
DAQCard-AI-16XE-50	16	16-bit	PCMCIA	AI
DAQPad-MIO-16XE-50	16	16-bit	Parallel Port	MIO
DAQPad-6020E	16	12-bit	USB	MIO
DAQPad-6052E	16	16-bit	1394	MIO
DAQPad-6070E	16	12-bit	1394	MIO
NEC-AI-16E-4	16	12-bit	NEC	AI
NEC-AI-16XE-50	16	16-bit	NEC	AI
NEC-MIO-16E-4	16	12-bit	NEC	MIO
NEC-MIO-16XE-50	16	16-bit	NEC	MIO
PCI-6023E	16	12-bit	PCI	AI
PCI-6024E	16	12-bit	PCI	MIO
PCI-6025E	16	12-bit	PCI	MIO
PCI-6031E (MIO-64XE-10)	64	16-bit	PCI	MIO
PCI-6032E (AI-16XE-10)	16	16-bit	PCI	AI
PCI-6033E (AI-64XE-10)	64	16-bit	PCI	AI
PCI-6052E	16	16-bit	PCI	MIO
PCI-6071E (MIO-64E-1)	64	12-bit	PCI	MIO
PCI-6110E	4 DIFF only	12-bit AI, 16-bit AO	PCI	MIO
PCI-6111E	2 DIFF only	12-bit AI, 16-bit AO	PCI	MIO
PCI-MIO-16E-1	16	12-bit	PCI	MIO
PCI-MIO-16E-4	16	12-bit	PCI	MIO
PCI-MIO-16XE-10	16	16-bit	PCI	MIO

Table 1. MIO and AI Device Classification (Continued)

Device	Number of SE Channels	Bit	Type	Functionality
PCI-MIO-16XE-50	16	16-bit	PCI	MIO
PXI-6011E	16	16-bit	PXI	MIO
PXI-6023E	16	12-bit	PXI	AI
PXI-6024E	16	12-bit	PXI	MIO
PXI-6025E	16	12-bit	PXI	MIO
PXI-6030E	16	16-bit	PXI	MIO
PXI-6040E	16	12-bit	PXI	MIO
PXI-6052E	16	16-bit	PXI	MIO
PXI-6070E	16	12-bit	PXI	MIO
VXI-MIO-64E-1	64	12-bit	VXI	MIO
VXI-MIO-64XE-10	64	16-bit	VXI	MIO

Related Documentation

For detailed hardware information, refer to the user manual included with each device. For detailed software information, refer to your NI-DAQ for PC compatibles documentation.

Customer Communication

National Instruments wants to receive your comments on our products and manuals. We are interested in the applications you develop with our products, and we want to help if you have problems with them. To make it easy for you to contact us, this guide contains comment and configuration forms for you to complete. These forms are in the *Customer Communication* appendix at the end of this guide.

MIO and AI Devices

This chapter contains overview information on the MIO and AI devices. These devices are listed in Table 1-1.

MIO and AI Multifunction I/O Devices

The National Instruments MIO and AI devices are collectively known as E Series devices. Timing and control on these devices is performed by the National Instruments Data Acquisition System Timing Controller (DAQ-STC) chip.

MIO and AI Device Analog Input

Table 1-1 summarizes the key analog input characteristics for the MIO and AI multifunction I/O devices.

Table 1-1. MIO and AI Multifunction I/O Device Analog Input Characteristics

Device	Number of Channels	ADC Resolution (Bits)	Gains	Range (V)	Input FIFO (Words)	Hardware Analog Trigger
AT-MIO-16DE-10, AT-MIO-16E-10 DAQPad-6020E	16	12	0.5, 1, 2, 5, 10, 20, 50, 100	$\pm 5, 0$ to 10	512	no
AT-MIO-16E-1	16	12	0.5, 1, 2, 5, 10, 20, 50, 100	$\pm 5, 0$ to 10	8,192	yes
AT-MIO-16E-2, NEC-AI-16E-4, NEC-MIO-16E-4	16	12	0.5, 1, 2, 5, 10, 20, 50, 100	$\pm 5, 0$ to 10	2,048	yes
6023E, 6024E, 6025E devices	16	12	0.5, 1, 10, 100	$\pm 5, 0$ to 10	512	no

Table 1-1. MIO and AI Multifunction I/O Device Analog Input Characteristics (Continued)

Device	Number of Channels	ADC Resolution (Bits)	Gains	Range (V)	Input FIFO (Words)	Hardware Analog Trigger
DAQPad-6070E, PCI-MIO-16E-4, PCI-MIO-16E-1, PXI-6040E, PXI-6070E	16	12	0.5, 1, 2.5, 5, 10, 20, 50, 100,	±5, 0 to 10	512	yes
DAQCard-AI-16E-4	16	12	0.5, 1, 2, 5, 10, 20, 50, 100	±5, 0 to 10	1,024	yes
AT-MIO-16XE-10, AT-AI-16XE-10	16	16	1, 2, 5, 10, 20, 50, 100	±10, 0 to 10	2,048	yes
AT-MIO-16XE-50, DAQPad-MIO-16XE-50, NEC-AI-16XE-50, NEC-MIO-16XE-50, PCI-MIO-16XE-50	16	16	1, 2, 10, 100	±10, 0 to 10	512	no
DAQCard-AI-16XE-50	16	16	1, 2, 10, 100	±10, 0 to 10	1,024	no
AT-MIO-64E-3	64	12	0.5, 1, 2, 5, 10, 20, 50, 100	±5, 0 to 10	2,048	yes
PCI-MIO-16XE-10, PCI-6032E (AI-16XE-10) PXI-6030E	16	16	1, 2, 5, 10, 20, 50, 100	±10, 0 to 10	512	yes
6052E devices	16	16	0.5, 1, 2.5, 5, 10, 20, 50, 100	±5, 0 to 10	512	yes
VXI-MIO-64E-1	64	12	0.5, 1, 2, 5, 10, 20, 50, 100	±5, 0 to 10	8,192	yes
PCI-6110E	4	12	0.2, 0.5, 1, 2, 5, 10, 20, 50	±10	512	yes
PCI-6111E	2	12	0.2, 0.5, 1, 2, 5, 10, 20, 50	±10	512	yes

Table 1-1. MIO and AI Multifunction I/O Device Analog Input Characteristics (Continued)

Device	Number of Channels	ADC Resolution (Bits)	Gains	Range (V)	Input FIFO (Words)	Hardware Analog Trigger
PCI-6031E (MIO-64XE-10), PCI-6033E (AI-64XE-10) VXI-MIO-64XE-10	64	16	1, 2, 5, 10, 20, 50,100	± 10 , 0 to 10	512	yes
PXI-6071E (MIO-64E-1)	64	12	0.5, 1, 2, 5, 10, 20, 50, 100	± 5 , 0 to 10	512	yes



Note *Terms such as ADC resolution and analog trigger are defined in the Glossary.*

E Series Data Acquisition

The E Series devices can perform single-channel data acquisitions and multiple-channel scanned data acquisitions. For single-channel data acquisition, select a single analog input channel and gain setting. The device performs a single A/D conversion on that channel every sample interval.

For multiple-channel scanned data acquisition, the device scans a set of analog input channels, each with its own gain setting. In this method, a scan sequence indicates which analog channels to scan and the gain settings for each channel. The length of this scan sequence can be 1 to 512 channel/gain pairs. For the PCI-6110E and the PCI-6111E each channel can appear only once in the scan sequence.

During scanning, the analog input circuitry performs an A/D conversion on the next entry in the scan sequence. The device performs an A/D conversion once every sample interval. For maximum performance, this operation is pipelined so that the device switches to the next channel while the current A/D conversion is performed. The device waits for a specified scan interval before scanning the channels again. The channels are scanned repeatedly at the beginning of each scan interval until the required number of samples has been acquired. For example, you can scan a sequence of four channels once every 10 s. The device could sample the channels at the beginning of the 10 s interval, within 20 μ s, with a 5 μ s sample interval between channels. If you set the scan interval to 0, the scan sequence starts over

again immediately at the end of each scan sequence without waiting for a scan interval. The 0 scan interval setting causes the device to scan the channels repeatedly as fast as possible.

**Note**

The 611X devices sample all channels simultaneously. The scan interval controls the sampling rate, therefore the scan interval of zero is not allowed.

You can combine both single-channel and multiple-channel acquisition with any of the following additional modes:

- Posttrigger mode
- Pretrigger mode
- Double-buffered mode
- AMUX-64T mode
- SCXI mode

**Note**

The 611X devices do not support the AMUX-64T or SCXI modes.

Posttrigger mode collects a specified number of samples after the device receives a trigger. Refer to the *start trigger* discussion in the appropriate data acquisition timing section for your device later in this chapter for details. After the user-specified buffer is full, the data acquisition stops.

Pretrigger mode collects data both before and after the device receives a trigger, either through software or by applying a hardware signal. The device collects samples and fills the user-specified buffer without stopping until the device receives the *stop trigger* signal. Refer to the *stop trigger* discussion in the appropriate data acquisition timing section for your device later in this chapter for details. The device then collects a specified number of samples and stops the acquisition. The buffer is treated as a circular buffer—when the entire buffer has been written to, data is stored at the beginning again, overwriting the old data. When data acquisition stops, the buffer has samples from before and after the stop trigger occurred. The number of samples saved depends on the length of the user-specified buffer and on the number of samples specified to be acquired after receipt of the trigger.

Double-buffered mode, like pretrigger mode, also fills the user-specified buffer continuously. You can call `DAQ_DB_Transfer` to transfer old data into a second buffer before it is overwritten by new data.

`DAQ_DB_Transfer` transfers data out of one half of the buffer while the other half is filled with new data.

In the AMUX-64T mode, you use one, two, or four external AMUX-64T devices to extend the number of analog input channels available. You connect the external signals to the AMUX-64T device pins, instead of directly to the DAQ device pins.

You can use SCXI modules as a data acquisition front end for the device to condition the input signals and multiplex the channels. You can use all the modes just described in conjunction with SCXI. The *SCXI Modules and Compatible DAQ Devices* section in Chapter 14, *SCXI Hardware*, describes how to use the SCXI functions to set up the SCXI modules for a data acquisition to be performed by a DAQ device.



Note

The DAQPad-MIO-16XE-50 uses half-FIFO mode by default when doing interrupt data transfer operations for analog input with rates faster than 256 samples per second. The PCI E-Series and DAQCard E-Series devices use half-FIFO when performing interrupt data transfers for analog input with rates faster than 1000 samples per second. You can override the default setting and select between interrupt on every sample and interrupt on half-FIFO. When using external conversions, you should select the mode appropriate for the acquisition rate. To set the interrupt generation mode, see the Set_DAQ_Device_Info function in Chapter 2, Function Reference, of the NI-DAQ Function Reference Manual for PC Compatibles.

E Series Data Acquisition Timing

The following DAQ-STC counters are used for data acquisition timing and control:

The *scan counter* is used to control the number of scans you will acquire. If you want to perform pretriggered acquisition, this counter will ensure that you acquire selected number of scans before the stop trigger is recognized.

- The *scan timer* is a counter that you can use for *start scan* timing.
- The *sample-interval timer* is a counter that you can use for *conversion* timing.

The DAQPad-6020E uses half-FIFO mode when doing interrupt data transfer operations for analog input rates of > 256 samples per second.

Data acquisition timing involves the following timing signals:

- A *start trigger* is a signal that initiates a data acquisition sequence. You can supply this signal externally through a selected I/O connector pin, through a RTSI bus trigger line, or by software.

- A *start scan* signal initiates individual scans. This signal can be supplied from the onboard programmable scan timer, externally through a selected I/O connector pin, through a RTSI bus trigger line, or by software.
- A *conversion* signal initiates individual analog-to-digital (A/D) conversions. This signal can be supplied from the onboard programmable sample timer, externally through a selected I/O connector pin, through a RTSI bus trigger line, or by software.
- A *stop trigger* is a signal used for pretriggered data acquisition to notify your device to stop acquiring data after a specified number of scans. Data acquisition operation is continuously performed until the device receives this signal. This signal can be supplied externally through a selected I/O connector pin, through a RTSI bus trigger line, or by software.
- *Gate* is a signal used for gating the data acquisition. When you enable gating, the data acquisition will proceed only on selected level of the gate signal. This signal can be supplied externally through a selected I/O connector pin, through a RTSI bus trigger line.
- *Scan timer timebase* is a signal used by the scan timer for scan interval timing. This signal is used only when the scan timer is used. This signal can be supplied from one of the onboard timebase sources, externally through a selected I/O connector pin, or through a RTSI bus trigger line.
- *Sample interval timer timebase* is a signal used by the sample interval timer for conversion timing. This signal is used only when the sample interval timer is used. This signal can be supplied from one of the onboard timebase sources, externally through a selected I/O connector pin, or through a RTSI bus trigger line.

See your DAQ device user manual for more information regarding these signals.

DAQ devices with the DAQ-STC use two counters, the scan interval counter and the sample interval counter. The E Series devices support both internal and external timebases. The internal timebases available on the DAQ-STC are 20 MHz (50 ns) and 100 kHz (10 μ s). The scan interval counter is a 24-bit counter, and the sample interval counter is a 16-bit counter.

While the scan interval counter has the freedom to work with both internal and external timebases, the sample interval counter can use either the 20 MHz timebase or the timebase used by the scan interval counter.

When you specify a timebase value different from the internal timebases the DAQ-STC uses, NI-DAQ tries to convert the timebase and interval values you specified into those that the DAQ-STC can use. If NI-DAQ cannot make the translation without a loss of resolution, it returns **rateNotSupportedError**. This typically occurs if you specified a timebase of 5 (100 Hz) and a sample interval of 100, for example, for a resulting sample interval of 1 s. This generates an error because the sample interval counter rolls over before 1 s.

**Note**

The 611X devices use the scan interval counter to control the acquisition rate. The sample interval counter does not affect conversion timing since all channels are sampled simultaneously. The pipelined ADC used on 611X devices requires four conversions before the first sample becomes available; therefore, if you are using external conversions, you should allow for this behavior.

E Series DAQ Rates

Refer to the appropriate user manual for single-channel and multiple-channel DAQ rates and settling accuracy.

If you are using SCXI with your DAQ device, refer to the *SCXI Data Acquisition Rates* section in Chapter 3, *Software Overview*, of the *NI-DAQ User Manual for PC Compatibles*, for the effect of SCXI module settling time on your DAQ device rates.

MIO Device Analog Output

The MIO devices contain two analog output channels numbered 0 and 1. Each analog output channel contains either a 12-bit DAC or a 16-bit DAC, depending on the AO resolution of your device. You can configure each analog output channel for unipolar or bipolar voltage output except on the MIO-16XE-50 and the 611X devices, which are always in bipolar mode. An onboard voltage reference of +10 V is available for the analog output channels. An external reference voltage signal can also drive the analog output channels except on the MIO-16XE-10, MIO-16XE-50 and the 611X devices. See the `AO_Configure` function in Chapter 2, *Function Reference*, of the *NI-DAQ Function Reference Manual for PC Compatibles* for more information about configuring the DACs.

**Note**

The 611X devices require an even number of samples in the waveform buffer due to a 32-bit wide output FIFO necessary for high-speed data transfers.

MIO Device Waveform Generation

The Waveform Generation functions can write values to either one or both analog output channels continuously using an onboard or external clock to update the DACs at regular intervals. The values are contained in a buffer that you allocate and fill. The resultant voltages produced at the analog output channels depend on the value of the numbers in the buffer, the level of the reference voltage, and the polarity setting.



Note

(E Series devices on VXI, ISA, PCI, PXI and 1394 buses only) NI-DAQ can use either DMA or interrupt service routines to generate waveforms on the analog output channels. By default, NI-DAQ uses DMA because DMA is simply more efficient. If you prefer to reserve the DMA channels for the Data Acquisition functions or for other devices in the system, call Set_DAQ_Device_Info (described in Chapter 2, Function Reference, of the NI-DAQ Function Reference Manual for PC Compatibles) to force NI-DAQ not to use DMA for waveform generation.

E Series Waveform Generation Using Onboard Memory

All E Series devices with analog output FIFOs support FIFO mode waveform generation. In this mode, waveform data is transferred to the onboard DAC FIFO memory only once. These values are then cycled through to generate the waveform continuously or for a finite number of iterations. No interrupt service or DMA operation is required to transfer more data to the device during waveform generation.

The following conditions must be satisfied to use FIFO mode waveform generation:

- One cycle worth of waveform data can be held entirely on the device DAC FIFO memory.
- Double-buffered waveform generation mode is disabled.
- The number of cycles to generate can be infinite (denoted by the value 0), or between 1 and 16,777,216 inclusive.

There are two variations possible in FIFO mode waveform generation:

- Continuous cyclic waveform generation—An onboard counter or an external signal provides the update pulses. Once started, the waveform generation continues until you call the clear function to stop the waveform.

- Programmed cyclic waveform generation—An onboard counter or an external signal provides the update pulses. A separate onboard counter terminates the waveform after a finite number of cycles has been generated.

Refer to your DAQ device manual to determine the size of the analog output FIFO and for more information on waveform generation.

E Series Digital I/O

The E Series devices contain one 8-bit digital I/O port supplied by the DAQ-STC chip. This port is referred to as port 0 by the Digital I/O functions.

You can configure the entire digital port as either an input or an output port, or you can configure individual lines for either input or output. The port has *read-back capability*. This port operates in nonlatched mode only.



Note

Connecting one or more AMUX-64T devices or a non-remote SCXI chassis to an E Series device renders various lines of the digital I/O port unavailable:

One AMUX-64T device—Lines 0 and 1 are unavailable.

Two AMUX-64T devices—Lines 0, 1, and 2 are unavailable.

Four AMUX-64T devices—Lines 0, 1, 2, and 3 are unavailable.

SCXI—Lines 0, 1, 2, and 4 are unavailable.

The remaining lines of the digital I/O port are available for input or output. You should use DIG_Line_Config to configure these remaining lines.

The AT-MIO-16DE-10 and the 6025E devices have one 8-bit line-configurable port named port 0 that does not support handshaking or asynchronous operations. The DAQ-STC chip supplies this port. The AT-MIO-16DE-10 and the 6025E devices also have three 8-bit ports named ports 2, 3, and 4 that do support handshaking and asynchronous operations and are directionally configurable only on a per-port basis. An 8255 chip supplies these three ports. The three 8255 ports are numbered 2, 3, and 4 for compatibility with an older product. Table 1-2 summarizes the four ports available on the AT-MIO-16DE-10 and the 6025E devices.

Table 1-2. AT-MIO-16DE-10 and 6025E Device Ports

Port	Size	Configuration	Type	Supplied by
0	8-bit	Line configurable	Immediate	DAQ-STC chip
2	8-bit	Handshaking	Asynchronous or immediate	8255 chip
3	8-bit	Handshaking	Asynchronous or immediate	8255 chip
4	8-bit	—	Immediate	8255 chip

For a description of the AT-MIO-16DE-10 and the 6025E device digital I/O, see Chapter 9, *DIO-24, AT-MIO-16DE-10, and 6025E Devices*.

E Series Counter/Timer Operation

The E Series devices use the National Instruments DAQ-STC counter/timer chip. The DAQ-STC has two 24-bit counter/timers that are always available for general-purpose counter/timer applications. Refer to the GPCTR functions in Chapter 2, *Function Reference*, of the *NI-DAQ Function Reference Manual for PC Compatibles* for more information.

E Series Programmable Frequency Output Operation

The E Series devices have one I/O connector pin (FREQ_OUT) capable of outputting a programmable frequency signal. This signal is a divided-down version of the selected timebase. Available timebases for this operation are 10 MHz and 100 kHz, and you can divide them by numbers 1 through 16.

E Series PFI Pins

You can route internal device signals to and from the I/O connector programmatically by using the PFI pins on the E Series devices. Refer to your E Series device user manual for a complete discussion of PFI pins. See the `Select_Signal` function description in the Chapter 2, *Function Reference*, of the *NI-DAQ Function Reference Manual for PC Compatibles*, for programming information on routing.

Lab and 1200 Devices

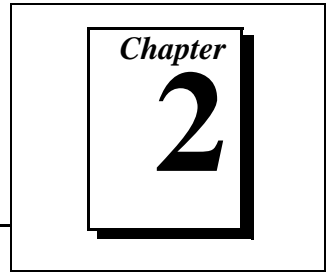

This chapter contains overview information on the DAQCard-1200, DAQPad-1200, Lab-PC+, Lab-PC-1200, Lab-PC-1200AI, PCI-1200, and SCXI-1200 devices.

Lab and 1200 Devices Analog Input

The Lab and 1200 devices contain eight single-ended analog input channels numbered 0 through 7. The analog input channels are multiplexed into a single programmable gain stage and 12-bit ADC. The devices have gains of 1, 2, 5, 10, 20, 50, and 100.

You can configure the input channels to be differential or nonreferenced single ended. In differential mode, four channels are available, namely, 0, 2, 4, and 6. All Lab and 1200 devices except the Lab-PC+ support software configuration of the input mode; on the Lab-PC+, configure the mode via jumper W4.

You can hardware jumper-configure analog input on the Lab-PC+ and software configure analog input on all other Lab and 1200 devices for two different input ranges:

- 0 to +10 V (unipolar)
- -5 to +5 V (bipolar)

You can initiate A/D conversions through software or by applying active low pulses to the EXTCONV* input on the device I/O connector. Each of the devices has a FIFO on the device in which to store the results of A/D conversions temporarily. Table 2-1 shows the FIFO sizes.

Table 2-1. Lab and 1200 Devices and Corresponding FIFO Size

Device	FIFO Size (in words)
Lab-PC+	512
DAQCard-1200, DAQPad-1200, Lab-PC-1200, Lab-PC-1200AI, PCI-1200, SCXI-1200	2,048

Lab and 1200 Devices Data Acquisition

The Lab and 1200 devices can perform single-channel data acquisition and multiple-channel scanned data acquisition. For single-channel data acquisition, you select a single analog input channel and gain setting. The board performs a single A/D conversion on that channel every sample interval.

For multiple-channel scanned data acquisition, the devices scan a sequence of analog input channels. A single gain setting is used for all channels scanned. A *sample interval* indicates the time to elapse between A/D conversions on each channel in the sequence. You need only to select a single starting channel to select the sequence of channels to scan. The board then scans the channels in consecutive order until channel 0 is reached, and then the scan begins anew with the starting channel. For example, if the starting channel is channel 3, the scan sequence is as follows:

channel 3, channel 2, channel 1, channel 0, channel 3, and so on

The Lab and 1200 devices support interval scanning. A scan interval is the time that elapses between two channel-scanning cycles.

You can combine both the single-channel and multiple-channel acquisitions with any of the following additional modes:

- Posttrigger mode
- Pretrigger mode
- Double-buffered mode
- SCXI mode (except the DAQPad-1200)

Posttrigger mode collects a specified number of samples after the board receives a trigger. You can initiate posttrigger acquisition through software or when a pulse edge is applied to the EXTTRIG input. After the user-specified buffer has been filled, the data acquisition stops.

Pretrigger mode collects data both before and after the board receives a trigger. You can initiate data acquisition through software. The device collects samples and fills the user-specified buffer without stopping or counting samples until the device receives a pulse at the EXTTRIG input. The device then collects a specified number of samples and stops the acquisition. The buffer is treated as a circular buffer—when the entire buffer has been written to, data is stored at the beginning again, overwriting the old data. When data acquisition stops, the buffer has samples from before and after the stop trigger occurred. The number of samples saved depends on the length of the user-specified buffer and on the number of samples specified to be acquired after receipt of the trigger.

Because there is only one EXTTRIG input on the device I/O connector, a single acquisition cannot employ both of these trigger modes.

Double-buffered mode, like pretrigger mode, also fills the user-specified buffer continuously. Unlike pretrigger mode, however, double-buffered mode transfers old data into a second buffer before overwriting the old data with new data. Data is transferred out of one half of the buffer while the other half is being filled with new data. You can use double-buffered mode in conjunction with either pretrigger or posttrigger modes.

You can use SCXI modules as a data acquisition front end for all Lab and 1200 devices except the DAQPad-1200 to signal condition the input signals and multiplex the channels. You can use all the modes just described in conjunction with SCXI for single-channel acquisitions; however, onboard multiple-channel acquisitions are only supported when using the SCXI-1120, SCXI-1120D, or SCXI-1121 modules in parallel mode. Chapter 14, *SCXI Hardware*, describes how the SCXI functions are used to set up the SCXI modules for a data acquisition to be performed by a DAQ device.

**Note**

Refer to the Set_DAQ_Device_Info function in Chapter 2, Function Reference, of the NI-DAQ Function Reference Manual for PC Compatibles for information on data transfer modes.

Lab and 1200 Devices Data Acquisition Timing

Timing for data acquisition can be performed by the two onboard 8253 Counters/Timers or externally. Each 8253 Counter/Timer has three independent 16-bit counters/timers.

- Counter A0 is a sample-interval counter reserved for data acquisition.
- Counter A1 is a sample counter reserved for data acquisition.
- Counter A2 is an update-interval counter reserved for waveform generation.
- Counter B0 is used for extending the timebase for data acquisition or waveform generation when the interval between samples or updates is greater than 65,535.
- Counter B1 is available for general-purpose counting functions. However, it is reserved during data acquisition interval scanning.
- Counter B2 is available for general-purpose counting functions.

Data acquisition timing involves the following timing signals:

- A *start trigger* is an edge-triggered signal that initiates a data acquisition sequence. You can supply a trigger pulse either externally through the I/O connector EXTTRIG input or from software control. You can enable a hardware start trigger by calling `DAQ_Config`.
- A *conversion pulse* is a signal that generates a pulse once every sample interval, causing an A/D conversion to be initiated. This signal can be generated by the onboard, programmable sample-interval clock supplied by the 8253 Counter/Timer on the Lab and 1200 device, or can be supplied externally through the I/O connector EXTCONV* input. You can select external conversion pulses by calling `DAQ_Config`. If you do not want to use external conversion pulses, you should disconnect the EXTCONV* pin on the I/O connector to prevent extra conversions.
- A *scan-interval pulse* is a signal that generates a pulse every scan. The scan clock for interval scanning pulses can be generated by the onboard, programmable scan-interval counter, or can be supplied through the OUTB1 pin on the I/O connector.
- A *sample counter* is used when conversion pulses are generated either by the onboard sample-interval counter or externally. The sample counter tallies the number of A/D conversions (samples) and shuts down the data acquisition timing circuitry when the board has acquired the desired number of samples.

- A *stop trigger* is a signal used for pretriggered data acquisition to notify the Lab and 1200 device to stop acquiring data after a specified number of samples. Until you apply the stop trigger pulse at the EXTTRIG input, a data acquisition operation remains in a continuous acquisition mode, indefinitely writing and rewriting data to the buffer. You can select pretriggering by calling `DAQ_StopTrigger_Config`.
- A *timebase clock* is a clock signal that is the timebase for the sample-interval or scan-interval counter. Counter B0 is used to provide the timebase clock when the interval between samples or updates is greater than 65,535 μs . The timebase for sample and scan interval is the same.

See your device user manual for more information regarding these signals.



Note

The Lab and 1200 devices use half-FIFO mode by default when doing interrupt data transfer operations for analog input with rates faster than 1500 S/s. You can select between interrupt on every sample and interrupt on half-FIFO. When using external conversions, you should select the mode appropriate for the acquisition rate. See `Set_DAQ_Device_Info` function in Chapter 2, Function Reference, of the NI-DAQ Function Reference Manual for PC Compatibles to set the interrupt generation mode.

Lab and 1200 Devices Data Acquisition Rates

Table 2-2 shows the maximum recommended data acquisition rates and the recommended values for settling time versus gain. The required settling time depends on the gain setting used for each channel. This settling time also limits data acquisition rates.

Table 2-2. Typical Settling Accuracies for Maximum Multiple-Channel Scanning Rates for the Lab and 1200 Devices

Gain	Maximum Acquisition Rate*	Settling Time
1	83.3 kS/s	12 μs
2, 5, 10, 20, 50	62.5 kS/s	16 μs
100	20 kS/s	50 μs
* If you are using remote SCXI, the maximum acquisition rate depends on baud rate and will most likely be much slower than the rates listed here.		

The settling accuracy is always ± 0.5 LSB.

If you are using SCXI, refer to the *SCXI Data Acquisition Rates* section in Chapter 3, *Software Overview*, of the *NI-DAQ User Manual for PC Compatibles* for the effect of SCXI module settling time on your DAQ device rates.

Lab and 1200 Devices Analog Output

The Lab and 1200 devices contain two analog output channels numbered 0 and 1. Each analog output channel contains a 12-bit DAC. The DACs are double buffered, which facilitates accurate waveform generation via the delayed update mode. On the Lab-PC+, you can hardware jumper configure each analog output channel for unipolar or bipolar voltage output. On all other Lab and 1200 devices, you can software configure each analog output channel. An onboard voltage reference of +5 V is provided for the analog output channels.

Lab and 1200 Devices Waveform Generation

The Waveform Generation functions can continuously write values to either one or both analog output channels using an onboard or external clock to update the DACs at regular intervals. The values are contained in a buffer that you allocate and fill. The resultant voltages produced at the analog output channels depend on the value of the integer numbers in the buffer, the level of the reference voltage, and the polarity setting.

Lab and 1200 Devices Digital I/O

The Lab and 1200 devices contain 24 bits of digital I/O. These bits are divided into a set of three digital I/O ports of eight bits each. The Intel 8255A Parallel Peripheral Interface chip controls digital I/O. The digital I/O ports are labeled as ports PA, PB, and PC on the I/O connectors, as shown in your device user manual.

You can configure all three ports as either input ports or output ports. These ports are referred to as ports 0, 1, and 2 for the digital I/O functions, in which:

- Port PA = port 0
- Port PB = port 1
- Port PC = port 2

Ports 0 and 1 support both handshaking and no-handshaking modes. Port 2 supports no-handshaking mode only. The digital lines making up port 2 (PC) are used as handshaking lines for both ports 0 and 1 whenever either is configured for handshaking mode; therefore, port 2 is not available for Digital I/O functions whenever either port 0 or port 1 is configured for handshaking mode.

Using a non-remote SCXI chassis with a Lab-PC+ or a DAQCard-1200 or using an SCXI-1200 in multiplexed mode renders port PB unavailable. NI-DAQ also reserves line 0 of port PC for input from the SCXI hardware if you have SCXI configured. The remaining lines of port PC are available for input only.

Lab and 1200 Devices Groups

You can group any combination of ports 0 and 1 together to make up larger ports.

Lab and 1200 Devices Interval Counter/Timer Operation

Figure 2-1 diagrams the available 16-bit counters:

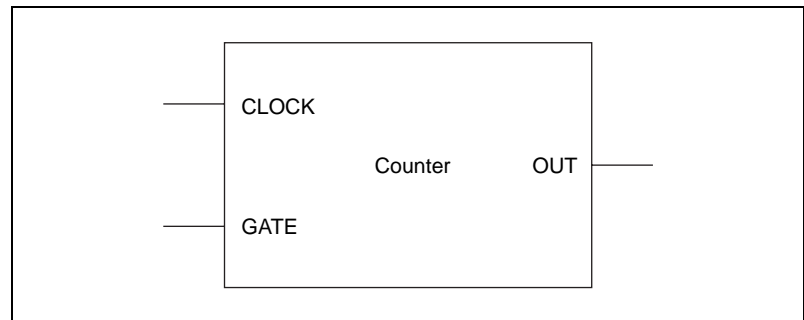

Figure 2-1. Lab and 1200 Device Interval Counter Block Diagram

Each counter has a clock input, a gate input, and an output. You can use a counter to count the falling edges of the signal applied to the CLK input. The Lab and 1200 devices use the counter gate input to gate counting operations. Refer to the counter data sheet included in your device user manual to see how the gate inputs affect the counting operation in different counting modes.

Lab and 1200 Devices Counter/Timers

The Lab and 1200 devices contain two onboard 8253 Programmable Interval Timer chips that have three independent 16-bit counter/timers. One of these chips, the 8253-A, is reserved for data acquisition and waveform generation operations. You can use the three counters on the other chip, the 8253-B, for counting/timing operations. NI-DAQ uses the three counter/timers from the 8253-B as follows:

- Counter 0 is used for extending the timebase for data acquisition or waveform generation when the interval between samples or updates is greater than 65,535 μ s.
- Counter 1 can be reserved for data acquisition using interval scanning on all Lab and 1200 devices or Track*/Hold manipulation for the SCXI-1140 with all Lab and 1200 devices except the DAQPad-1200. Counter 1 is otherwise available for counting/timing operations.
- Counter 2 is always available.

Figure 2-2 shows the connections of the 8253-B Counter/Timer signals to the device I/O connector.

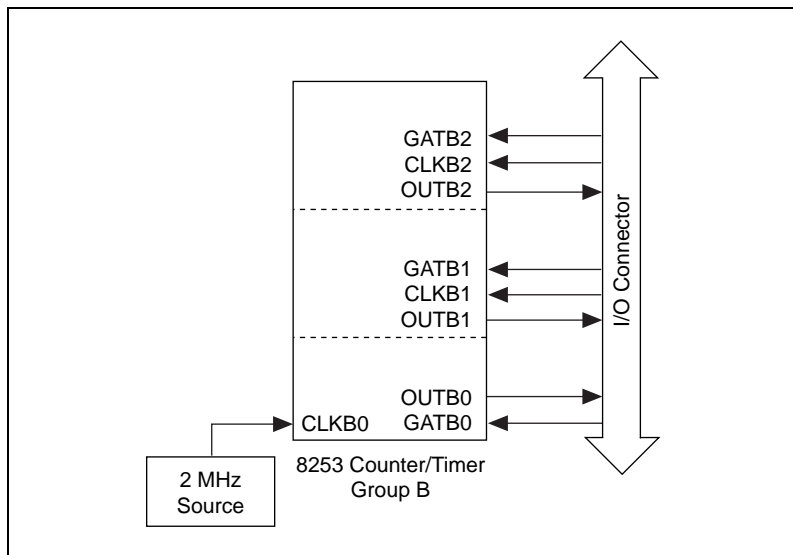

Figure 2-2. Lab and 1200 Devices Counter/Timer Signal Connections

Each counter has a clock input, a gate input, and an output labeled CLK, GAT, and OUT, respectively. The clock pin for counters B1 and B2 and the gate and output pins for counter B0, B1, and B2 are on the Lab and 1200 device I/O connector.

1200 Device Acquisition Rate

All I/O operations for the DAQCard-1200, DAQPad-1200, and SCXI-1200 are interrupt driven.



Note

If you are using the parallel port of your PC to communicate with the SCXI-1200 or the DAQPad-1200, your acquisition rates will be limited by the type of parallel port you have in your system (either a standard Centronics port or an Enhanced parallel port). Because both devices have a 2,048-word-deep FIFO, you can acquire bursts of less than 2,048 samples at maximum speed. If you are using the serial port of your PC to communicate with the SCXI-1200 in a Remote SCXI configuration, your acquisition rates will be limited by the serial port baud rate you are using.

As with all interrupt-driven operations, you can exceed the ability of your system to handle the interrupt traffic if you increase your analog input sampling rate or analog output update rate beyond your system's capability. To determine the limits of your system, start at lower rates and gradually increase them until your computer operations begin to slow down.

DAQPad-1200 Printer Connection

The DAQPad-1200 is equipped with a pass-through parallel port to connect to a printer. To print with this configuration, the DAQPad-1200 must be in an idle state. The DAQPad-1200 is idle when it is not generating any interrupts. In other words, do not try to print while running an asynchronous analog I/O or digital I/O operation.

1200 Device Calibration

All 1200 devices are shipped with factory-calibration coefficients stored in an EEPROM. If you want to recalibrate either coefficient, use the `Calibrate_1200` function.



Note

Calling this function on an SCXI-1200 with remote SCXI might take an extremely long time. We strongly recommend that you switch your SCXI-1200 to use a parallel port connection before performing the calibration and store the calibration constants in one of the EEPROM storage locations.

LPM Devices

Chapter

3

This chapter contains overview information on the PC-LPM-16 and PC-LPM-16PnP.

LPM Device Analog Input

The LPM devices contain 16 multiplexed, single-ended analog input channels numbered 0 through 15. The analog input channels are driven into a 12-bit, self-calibrating ADC. The devices have no gains on the analog input.

You can configure analog input (hardware jumpers on the PC-LPM-16 or software configuration on the PC-LPM-16PnP) for four different input ranges:

- 0 to +5 V (unipolar)
- 0 to +10 V (unipolar)
- -2.5 to +2.5 V (bipolar)
- -5 to +5 V (bipolar)

You can initiate A/D conversions through software or by applying active low pulses to the EXTCONV* input on the I/O connector. On the PC-LPM-16, a 16-word-deep FIFO memory on the device stores up to 16 A/D conversion results; on the PC-LPM-16PnP, a 256-word-deep FIFO stores up to 256 A/D conversion results.

LPM Device Data Acquisition

The LPM devices can perform single-channel data acquisition and multiple-channel scanned data acquisition. For single-channel data acquisition, you select a single analog input channel. The device performs a single A/D conversion on that channel every sample interval.

For multiple-channel scanned data acquisition, the device scans a sequence of analog input channels. A sample interval indicates the time to elapse between A/D conversions on each channel in the sequence. You need to select only a single starting channel to select the sequence of channels to

scan. The device then scans the channels in consecutive order until channel 0 is reached and the scan begins anew with the starting channel. If the starting channel is channel 3, for example, the scan sequence is as follows:

channel 3, channel 2, channel 1, channel 0, channel 3, and so on

You can use both the single-channel and multiple-channel acquisitions with the double-buffered mode. Double-buffered mode fills the user-specified buffer continuously. You can call the `DAQ_DB_Transfer` to transfer old data into a second buffer before overwriting the old data with new data. NI-DAQ transfers data out of one half of the buffer while filling the other half with new data.

LPM Device Data Acquisition Timing

Timing for data acquisition can be performed by the onboard MSM82C53 counter/timer or externally. The MSM82C53 Counter/Timer has three independent 16-bit counters/timers, which are assigned as follows:

- Counter 0 is a sample-interval counter for data acquisition that is available if no data acquisition is in progress.
- Counter 1 is available for general-purpose counting functions.
- Counter 2 is available for general-purpose counting functions.

Data acquisition timing involves the following timing signals:

- A *conversion pulse* is a signal that generates a pulse once every sample interval, causing the device to initiate an A/D conversion. This signal can be generated by the onboard, programmable sample-interval clock supplied by the MSM82C53 Counter/Timer on the LPM device, or can be supplied externally through the I/O connector EXTCONV* input. You can select external conversion pulses by calling `DAQ_Config`. If you do not want to use external conversion pulses, you should disconnect the EXTCONV* pin on the I/O connector to prevent extra conversions.
- A *timebase clock* is a clock signal that is the timebase for the sample-interval counter. Counter 0 of the MSM82C53 uses a 1 MHz clock as its timebase.

See your device user manual for more information regarding these signals.

LPM Device Data Acquisition Rates

Table 3-1 shows the maximum recommended data acquisition rates.

Table 3-1. Maximum Recommended Data Acquisition Rates for the LPM Devices

Sample Mode	Maximum Acquisition Rate	Sample Interval
Single-channel scan	50 kS/s	20 μ s
Multiple-channel scan (0 to +5 V, -2.5 to +2.5 V, and -5 to +5 V input ranges)	50 kS/s	20 μ s
Multiple-channel scan (0 to 10 V input range)	50 kS/s (typical) 45 kS/s (worst case)	20 μ s 22 μ s

LPM Device Digital I/O

The LPM devices contain one 8-bit digital input port and one 8-bit digital output port. The digital I/O ports are labeled DIN and DOUT on the I/O connector, as shown in your device user manual. The ports are referred to as ports 0 and 1 for the Digital I/O functions, in which:

- DOUT = port 0
- DIN = port 1

You can program ports 0 and 1 for no-handshaking mode only. You can use port 0 for no-handshaking digital output mode. You can use port 1 for no-handshaking digital input mode.

LPM Device Interval Counter/Timer Operation

The LPM device interval counter/timer operation is the same as for the Lab-PC+, except that the LPM devices have a single counter. Refer to the *Lab and 1200 Devices Interval Counter/Timer Operation* section in Chapter 2, *Lab and 1200 Devices*, for detailed information.

LPM Device Counter/Timers

The LPM devices contain an onboard MSM82C53 Programmable Interval Timer chip that has three independent 16-bit counter/timers. NI-DAQ uses the three counter/timers from the 82C53 as follows:

- Counter 0 is used for data acquisition operations.
- Counter 1 is available for counting/timing operations.

Figure 3-1 shows the connections of the MSM82C53 Counter/Timer signals to the device I/O connector.

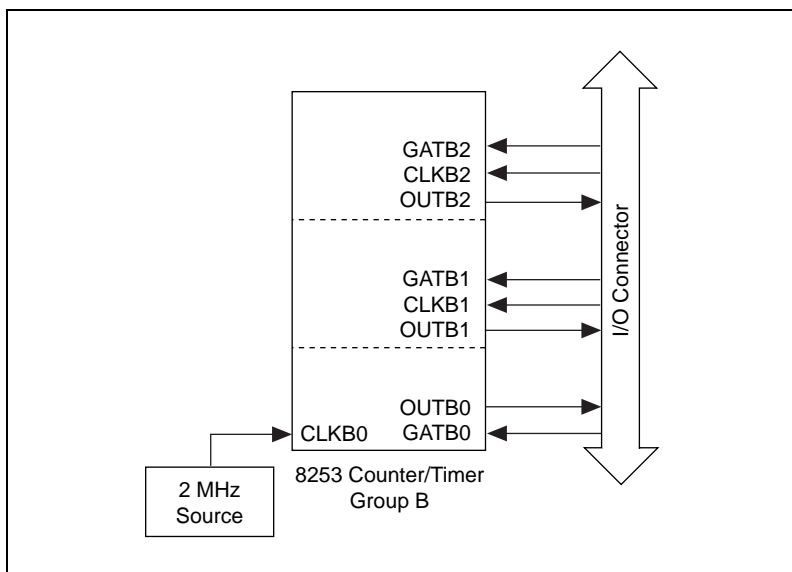

Figure 3-1. LPM Device Counter/Timer Signal Connections

The counter has a clock input, a gate input, and an output labeled CLK, GAT, and OUT, respectively. The clock pin for counters 1 and 2 and the gate and output pins for counters 1, 2, and 3 are available on the device I/O connector. The inverted OUT1 signal is also available on the I/O connector.

516 Devices and DAQCard-500/700 Devices

Chapter

4

This chapter contains overview information on the DAQCard-500, DAQCard-516, DAQCard-700, and PC-516.

516 Devices and DAQCard-500/700 Analog Input

The DAQCard-500 provides eight multiplexed, single-ended analog input channels. The DAQCard-700 provides 16 multiplexed, single-ended or eight multiplexed differential analog input channels. The analog input channels for both are driven into a 12-bit ADC. Neither device has gains on the analog input.

The 516 devices have eight single-ended or four differential analog inputs. Both devices use a 16-bit ADC and have no gains.

You can configure the DAQCard-700 analog input for three different bipolar input ranges:

- -2.5 to $+2.5$ V
- -5 to $+5$ V
- -10 to $+10$ V

You can configure the 516 devices and the DAQCard-500 for only the -5 to $+5$ V range.

You can initiate A/D conversions through software or by applying active low pulses to the EXTCONV* input on the device I/O connector. A 512-word-deep FIFO memory on the DAQCard-700 stores up to 512 A/D conversion results. On the DAQCard-500, a 16-word-deep FIFO stores up to 16 A/D conversion results. The DAQCard-516 has a 512-word-deep FIFO; the PC-516 has a 16-word-deep FIFO.

516 Devices and DAQCard-500/700 Data Acquisition

The 516 devices and DAQCard-500/700 can perform single-channel data acquisition and multiple-channel scanned data acquisition. For single-channel data acquisition, you select a single analog input channel. The device performs a single A/D conversion on that channel every sample interval.

For multiple-channel scanned data acquisition, the device scans a sequence of analog input channels. A sample interval indicates the time to elapse between A/D conversions on each channel in the sequence. You need only to select a single starting channel to select the sequence of channels to scan. The device then scans the channels in consecutive order until channel 0 is reached and the scan begins anew with the starting channel. If the starting channel is channel 3, for example, the scan sequence is as follows:

channel 3, channel 2, channel 1, channel 0, channel 3, and so on

You can use both the single-channel and multiple-channel acquisitions with the double-buffered mode. Double-buffered mode fills the user-specified buffer continuously. You can call the `DAQ_DB_Transfer` to transfer old data into a second buffer before overwriting the old data with new data. NI-DAQ transfers data out of one half of the buffer while filling the other half with new data.

You cannot use SCXI with the 516 devices or the DAQCard-500.



Note

The DAQCard-700 use half-FIFO mode by default when doing interrupt data transfer operations for analog input with rates faster than 1500 S/s. You can select between interrupt on every sample and interrupt on half-FIFO. When using external conversions, you should select the mode appropriate for the acquisition rate. See `Set_DAQ_Device_Info` function in Chapter 2, Function Reference, of the NI-DAQ Function Reference Manual for PC Compatibles to set the interrupt generation mode.

516 Devices and DAQCard-500/700 Data Acquisition Timing

Timing for data acquisition can be performed by the onboard MSM82C54 Counter/Timer or externally. The MSM82C54 Counter/Timer has three independent 16-bit counters/timers, which are assigned as follows:

- Counter 0 is a sample-interval counter for data acquisition that is available if no data acquisition is in progress. Signals for Counter 0 are not available on the I/O connector for the 516 devices and DAQCard-500.

- Counter 1 is available for general-purpose counting functions.
- Counter 2 is available for general-purpose counting functions.

Data acquisition timing involves the following timing signals:

- A *conversion pulse* is a signal that generates a pulse once every sample interval, causing the device to initiate an A/D conversion. This signal can be generated by the onboard, programmable sample-interval clock supplied by the MSM82C54 Counter/Timer, or can be supplied externally through the I/O connector EXTCONV* input. You can select external conversion pulses by calling `DAQ_Config`. If you do not want to use external conversion pulses, you should disconnect the EXTCONV* pin on the I/O connector to prevent extra conversions.
- A *timebase clock* is a clock signal that is the timebase for the MSM82C54 sample-interval counter. Counter 0 of the MSM82C54 uses a 1 MHz clock as its timebase.

See your device user manual for more information regarding these signals.

516 Devices and DAQCard-500/700 Digital I/O

The 516 devices and DAQCard-500 have one 4-bit digital input port and one 4-bit digital output port. The DAQCard-700 contains one 8-bit digital input port and one 8-bit digital output port. The digital I/O ports are labeled DIN and DOUT on the I/O connector, as shown in the appropriate device user manual. The ports are referred to as ports 0 and 1 by the Digital I/O functions, in which:

- DOUT = port 0
- DIN = port 1

You can program ports 0 and 1 for no-handshaking mode only. You can use port 0 for no-handshaking digital output mode. You can use port 1 for no-handshaking digital input mode.

516 Devices and DAQCard-500/700 Interval Counter/Timer Operation

DAQCard-700 Counter/Timers

The DAQCard-700 contains an onboard MSM82C54 Programmable Interval Timer chip that has three independent 16-bit counter/timers. NI-DAQ uses the three counter/timers from the 82C54 as follows:

- Counter 0 is used for data acquisition operations.
- Counter 1 is available for counting/timing operations.
- Counter 2 can be reserved for Track*/Hold manipulation for the SCXI-1140, and is otherwise available for counting/timing operations.

Figure 4-1 shows the connections of the MSM82C54 Counter/Timer signals to the DAQCard-700 I/O connector.

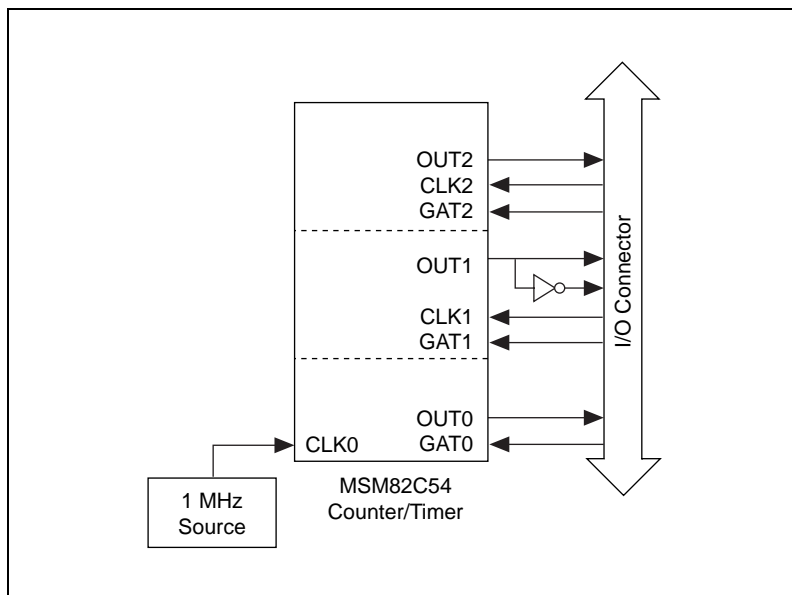

Figure 4-1. DAQCard-700 Counter/Timer Signal Connections

The counter has a clock input, a gate input, and an output labeled CLK, GATE, and OUT, respectively. The clock pin for counters 1 and 2 and the gate and output pins for counters 1, 2, and 3 are available on the device I/O

connector. The inverted OUT1 signal is also available on the DAQCard-700 I/O connector.

516 Devices and DAQCard-500 Counter/Timers

The 516 Devices and DAQCard-500 contain an onboard MSM82C54 Programmable Interval Timer chip that has three independent 16-bit counter/timers. NI-DAQ uses the three counter/timers from the 82C54 as follows:

- Counter 0 is used for data acquisition operations.
- Counter 1 is available for counting/timing operations.
- Counter 2 is available for counting/timing operations.

Figure 4-2 shows the connections of the MSM82C54 Counter/Timer signals to the 516 devices and DAQCard-500 I/O connector.

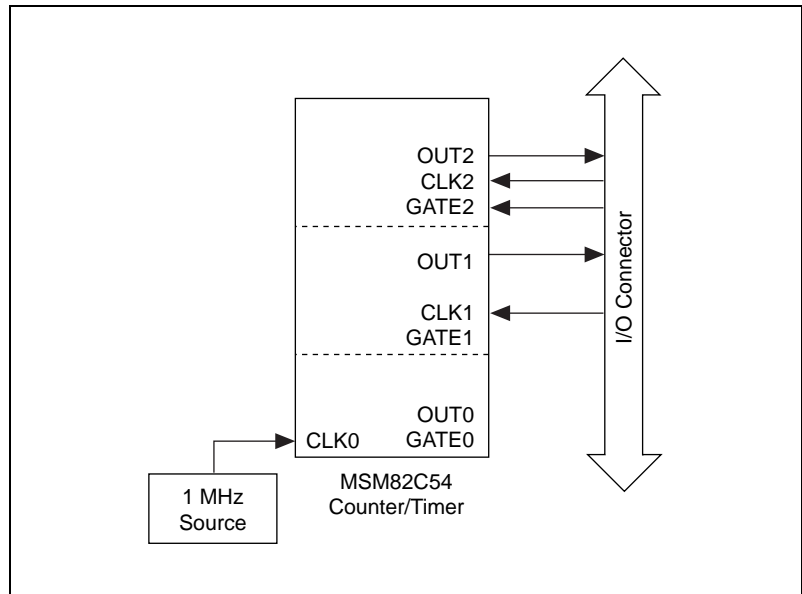

Figure 4-2. 516 Devices and DAQCard-500 Counter/Timer Signal Connections

The counter has a clock input, a gate input, and an output labeled CLK, GATE, and OUT, respectively. The clock pin for counters 1 and 2 and the output pins are available on the device I/O connector. The gate pin for counter 2 is also available on the I/O connector.

AT-AO-6/10 Analog Output Boards

Chapter

5

This chapter contains overview information on the AT-AO-6/10 analog output boards, including the AT-AO-6 and the AT-AO-10.

AT-AO-6/10 Analog Output

The AT-AO-6 and AT-AO-10 contain six or 10 analog output channels, respectively. Each analog output channel contains a 12-bit DAC. The DACs are double buffered, which facilitates accurate waveform generation via the delayed update mode. You can hardware jumper configure each analog output channel for unipolar or bipolar voltage output. An onboard voltage of +10 V or an externally connected voltage signal is available for analog output channel pairs as a voltage reference. There is a 4 to 20 mA current output associated with each analog output channel. You control the current output by writing voltages to the DACs with `AO_Write` or `AO_VWrite`. See the *AT-AO-6/10 User Manual* for the voltage/current relationship.

AT-AO-6/10 Waveform Generation

The waveform generation functions (*WFM*) can write values continuously to any number of analog output channels using an onboard or external clock to update the DACs at regular intervals. You can assign output channels to one of two groups. Each group has its own dedicated update clock. The values written to the DACs are contained in a buffer that you allocate and fill. The resultant voltages produced at the analog output channels depend on the value of the integer numbers in the buffer, the level of the reference voltage, and the polarity setting.

Waveform Generation Using Onboard Memory

The AT-AO-6/10 supports FIFO mode waveform generation. In this mode, the board transfers the values for one cycle of waveform to onboard DAC FIFO memory only once. Then the board cycles through these values to generate continuous waveform. Thus, no interrupt service or DMA operation is required to transfer more data to the FIFO.

The following conditions must be satisfied to use FIFO mode waveform generation:

- The waveform buffer fits in the DAC FIFO.
- Double-buffered waveform generation mode is disabled.
- The number of iterations is equal to 0 (continuous).

Note *This mode is available for group 1 only.*

Hardware Restrictions for the AT-AO-6/10

The following hardware restriction applies to the AT-AO-6/10:

- You cannot split channel pairs between groups (channel pairs are 0 and 1, 2 and 3, 4 and 5, and so on). For example, you can assign channel 4 alone to group 1, but you cannot then assign channel 5 to group 2.

AT-AO-6 group 1 assignments are as follows:

- 0 to n , where $n \leq 5$ and the channel list is consecutive, or any one channel.
- Uses interrupts/DMA with FIFO.
- Interrupt when the FIFO is half full; thus, group 1 will be faster than group 2, even when interrupts are used for both.
- If more than one channel is in the channel list, channel 0 must be the first channel in that list.

AT-AO-6 group 2 assignments are as follows:

- Channels 0 or 1 cannot be in group 2.
- Uses interrupts only.

AT-AO-10 group assignments are as follows:

- All rules of assignment for the AT-AO-6 apply to the AT-AO-10.
- 0 to n , where $n \leq 9$ and the channel list is consecutive, or any one channel.
- If exactly one channel is assigned to group 1, it cannot be channel 8 or 9.

AT-AO-6/10 Digital I/O

The AT-AO-6/10 contains eight bits of digital I/O. These bits are divided into a set of two digital I/O ports of four bits each. The 4-bit digital I/O ports are labeled as ports DIOA and DIOB. These ports are referred to as ports 0 and 1 by the Digital I/O functions, in which:

- Port DIOA = port 0
- Port DIOB = port 1

You can configure port 0 or 1 as either an input or an output port. Any port that you configured as an output port has *read-back capability*. The AT-AO-6/10 digital I/O ports operate in nonlatched mode only.

6704 Devices

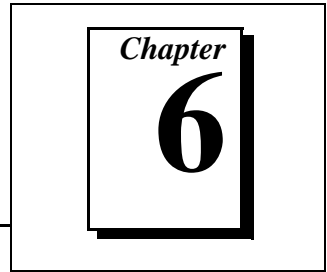

This chapter contains overview information on the PCI-6704 and PXI-6704 analog output boards.

PCI-6704 and PXI-6704 Analog Output Boards

The 6704 devices are precise DC setpoint analog output boards. These boards contain 16 voltage outputs plus 16 separate current outputs for a total of 32 analog output channels with 16-bit DAC resolution. Each channel is independently programmable. The voltage channels are numbered 0 through 15, and the current channels are 16 through 31. The analog output range is ± 10.1 V for the voltage channels and 0.1 to 20.2 mA for the current channels.

The 6704 devices have one 16-bit DAC that is time-division multiplexed to create the 16 voltage output channels and 16 current output channels. The channel data is stored in nonvolatile random access memory (RAM). This feature enables the boards to support the following update modes: update when written to and later internal update mode.

This design allows power-on values for all the analog output channels. All analog channels are guaranteed to be at their power-on values 5 ms after de-assertion of system reset.

PCI-6704 and PXI-6704 Digital I/O

The 6704 devices contain 8 lines of digital I/O. These lines are contained in one 8-bit port. You can configure each line individually for input or output. Each line you configure as an output line has *read-back capability*. These digital I/O ports operate in nonlatched mode only.

PC-TIO-10 Timing I/O Board

This chapter contains overview information on the PC-TIO-10 timing I/O board.

PC-TIO-10 Counter/Timer Operation

Am9513-Based Device Counter/Timer Operation

The PC-TIO-10 contains two Advanced Micro Devices (AMD) Am9513 System Timing Controller (STC) chips, each of which provides five independent 16-bit counter/timers and a 4-bit programmable frequency output, FOUT. Figure 7-1 illustrates the 16-bit counters available on the TIO devices.

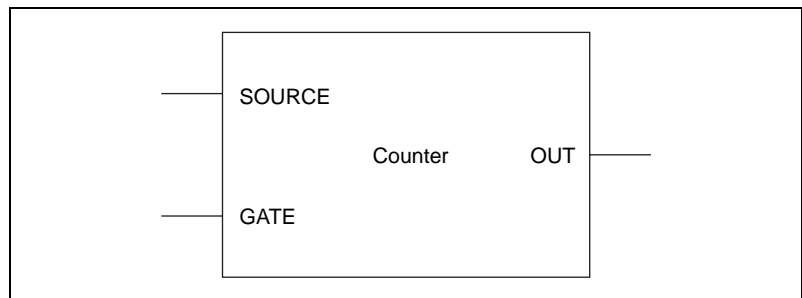

Figure 7-1. Counter Block Diagram

Each counter has a SOURCE input, a GATE input, and an output labeled OUT.

The counters can use several timebases for counting operations. A counter can use the signal supplied at any of the Am9513 five SOURCE or GATE inputs for counting operations. The Am9513 also makes available five internal timebases that any counter can use:

- 1 MHz clock (1 μ s resolution)
- 100 kHz clock (10 μ s resolution)

- 10 kHz clock (100 μ s resolution)
- 1 kHz clock (1 ms resolution)
- 100 Hz clock (10 ms resolution)

In addition, you can program the counter to use the output of the next lower-order counter as a signal source. This arrangement is useful for cascading-counters. For example, you can program counter 2 to count the output of counter 1, thus creating a 32-bit counter.

You can configure a counter to count either falling or rising edges of the selected internal timebase, SOURCE input, GATE input, or the next lower-order counter signal.

You can use the counter GATE input to gate counting operations. After you configure a counter through software for an operation, you can use a signal at the GATE input to start and stop the counter operation. There are eight gating modes available in the Am9513:

- No Gating—the counter is started and stopped by software.
- High-Level Gating—the counter is active when its gate input is at high-logic state. The counter is suspended when its gate input is at low-logic state.
- Low-Level Gating—the counter is active when its gate input is at low-logic state. The counter is suspended when its gate input is at high-logic state.
- Rising Edge Gating—the counter starts counting when it receives a low-to-high edge at its gate input.
- Falling Edge Gating—the counter starts counting when it receives a high-to-low edge at its gate input.
- High Terminal Count Gating—the counter is active when the next lower-order counter reaches terminal count (TC) and generates a TC pulse.
- High-Level Gate N+1 Gating—the counter is active when the gate input of the next higher-order counter is at high-logic state. Otherwise, the counter is suspended.
- High-Level Gate N-1 Gating—the counter is active when the gate input of the next lower-order counter is at high-logic state. Otherwise, the counter is suspended.

Counter operation starts and stops relative to the selected timebase. When you configure a counter for no gating, the counter starts at the first timebase/source edge (rising or falling, depending on the selection) after

the software configures the counter. When you configure a counter for gating modes, gate signals take effect at the next timebase/source edge. For example, if you configure a counter to count rising edges and to use the falling edge gating mode, the counter starts counting on the next rising edge after it receives a high-to-low edge on its GATE input. Thus, some time is spent synchronizing the GATE input with the timebase/source. This synchronization time creates a time lapse uncertainty from zero to one timebase period between the application of the signal at the GATE input and the start of the counter operation.

The counter generates timing signals at its OUT output. If the counter is not operating, you can set its output to one of three states—high-impedance state, low-logic state, or high-logic state.

The counters generate two types of output signals during counter operation: TC pulse output and TC toggled output. A counter reaches TC when it counts up (to 65,535) or down (to 0) and rolls over. In many counter applications, the counter reloads from an internal register when it reaches TC. In TC pulse output mode, the counter generates a pulse during the cycle in which it reaches TC. In TC toggled output mode, the counter output changes state on the next source edge after reaching TC. In addition, you can configure the counters for positive logic output or negative (inverted) logic output. Figure 7-2 shows examples of the four types of output signals generated.

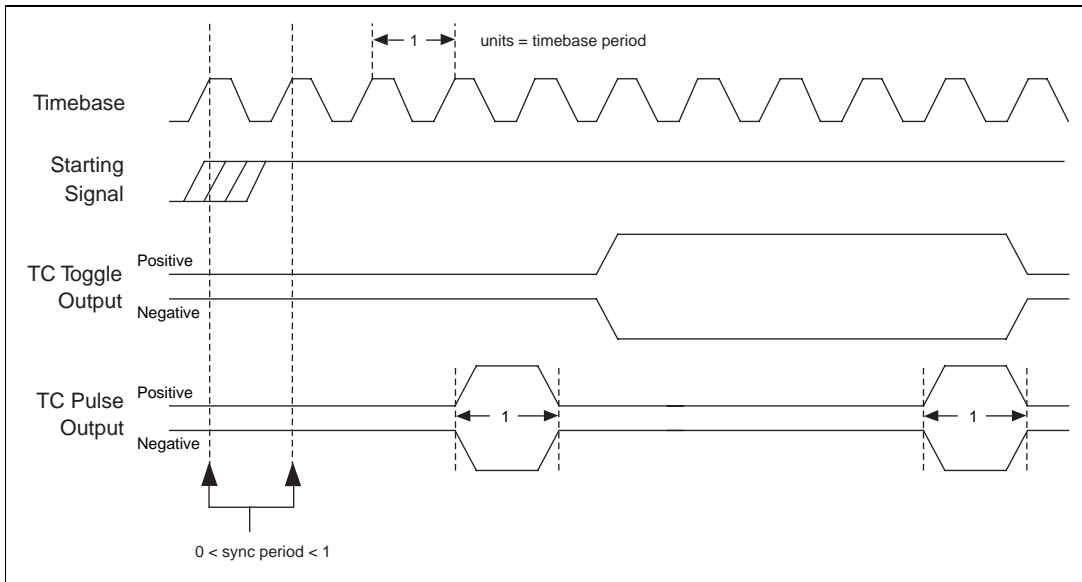

Figure 7-2. Am9513 Counter Timing and Output Types

Figure 7-2 represents a counter generating a delayed pulse and demonstrates the four forms the output pulse can take given the four different types of output signals supported. The TC toggled positive logic output looks like what would be expected when generating a pulse. For most of the Counter/Timer functions, TC toggled output is the preferred output configuration; however, the other signal types are also available. The starting signal shown in Figure 7-2 represents either a software starting of the counter, for the No-Gating mode, or some sort of signal at the GATE input. The signal could be either a rising edge gate or a high-level gate. If the signal is a low-level or falling edge gate, the starting signal simply appears inverted. In Figure 7-2, the counter is configured to count the rising edges of the timebase; therefore, the starting signal takes effect on the rising edge of the timebase, and the signal output changes state with respect to the rising edge of the timebase.

Programmable Frequency Output Operation

The Am9513-based devices have a 4-bit programmable frequency output signal. This signal is a divided-down version of the selected timebase. Any of five internal timebases, counter SOURCE inputs, and counter GATE inputs can be selected as the FOUT source. See the `CTR_FOUT_Config` function in Chapter 2, *Function Reference*, of the *NI-DAQ Function Reference Manual for PC Compatibles* for FOUT use and timing.

PC-TIO-10 Counter/Timers

The PC-TIO-10 contains two Advanced Micro Devices (AMD) Am9513 System Timing Controller (STC) chips, each of which provides five independent 16-bit counter/timers and a 4-bit programmable frequency output, FOUT. Each of the STCs is connected to an onboard 1 MHz frequency source, thus giving internal frequencies as specified previously. In addition, the SOURCE5 and SOURCE10 inputs are connected to a 5 MHz frequency source that yields increased timing resolution.

All counter/timers are available for general-purpose counting functions. All 10 counters and both FOUT outputs are connected to the I/O connector. The GATE, SOURCE, and OUTPUT lines of each of the counters except counters 5 and 10 are connected to the I/O connector. SOURCE5 and SOURCE10 are used as additional frequency inputs; consequently, only the GATE and OUTPUT lines of counters 5 and 10 are connected to the I/O connector.

Because the Am9513 integrated circuits operate independently, the next lower order counter of counter 1 is counter 5, and the next lower order counter of counter 6 is counter 10. Accordingly, the next higher order counter of counter 5 is counter 1, and the next higher order counter of counter 10 is counter 6.

PC-TIO-10 Digital I/O

The PC-TIO-10 board contains 16 bits of digital I/O. These bits are divided into a set of two digital I/O ports of eight bits each. The digital I/O ports are labeled as ports A and B on the I/O connector as shown in the *PC-TIO-10 User Manual*. These ports are referred to as ports 0 and 1 by the Digital I/O functions in which:

- Port A = port 0
- Port B = port 1

Digital I/O on this board is controlled by the Motorola MC6821 Peripheral Interface Adapter chip, the ports of which you can program on a bit-by-bit basis—you can configure each bit individually for input or output. In addition, any bit that you configure as an output bit has *read-back capability*.

DIO-96 Digital I/O Boards

Chapter

8

This chapter contains overview information on the DIO-96 digital I/O boards, including the PC-DIO-96, PC-DIO-96PnP, PCI-DIO-96, DAQPad-6507, DAQPad-6508, and PXI-6508.

DIO-96 Digital I/O

The DIO-96 boards contain 96 bits of digital I/O. These bits are divided into a set of 12 digital I/O ports of eight bits each. Digital I/O on this board is controlled by four Intel 8255A Parallel Peripheral Interface chips. The digital I/O ports are labeled as ports APA, APB, APC, BPA, BPB, BPC, CPA, CPB, CPC, DPA, DPB, and DPC on the I/O connector as shown in the *PC-DIO-96/PnP User Manual*. You can configure all 12 ports as either input ports or output ports.

These ports are referred to as ports 0 through 11 for the Digital I/O functions. Table 8-1 shows which port labels map to which port numbers and the modes you can use them in.

Table 8-1. DIO-96 Port Labels, Numbers, and Modes

Port Label	Port Number	Modes
APA	0	handshaking no-handshaking
APB	1	handshaking no-handshaking
APC	2	no-handshaking
BPA	3	handshaking no-handshaking
BPB	4	handshaking no-handshaking

Table 8-1. DIO-96 Port Labels, Numbers, and Modes (Continued)

Port Label	Port Number	Modes
BPC	5	no-handshaking
CPA	6	handshaking no-handshaking
CPB	7	handshaking no-handshaking
CPC	8	no-handshaking
DPA	9	handshaking no-handshaking
DPB	10	handshaking no-handshaking
DPC	11	no-handshaking

If you configure ports 0, 1, 3, 4, 6, 7, 9, and/or 10 for handshaking mode, you cannot use ports 2, 5, 8, and/or 11 with the Digital I/O functions because the board uses the digital lines in the latter ports as handshaking lines for other former ports. For example, when you configure either port 0 or port 1 for handshaking mode, the board uses port 2 as the handshaking lines, and you cannot use port 2 with Digital I/O functions. The criteria are as follows:

- Port 2 (APC) is unavailable when you configure either port 0 or 1 for handshaking mode.
- Port 5 (BPC) is unavailable when you configure either port 3 or 4 for handshaking mode.
- Port 8 (CPC) is unavailable when you configure either port 6 or 7 for handshaking mode.
- Port 11 (DPC) is unavailable when you configure either port 9 or 10 for handshaking mode.

DIO-96 Groups

You can group any combination of ports 0, 1, 3, 4, 6, 7, 9, and 10 on the DIO-96 to make up larger ports. For example, you can program ports 0, 3, 9, and 10 to make up a 32-bit handshaking port, or all eight ports to make up a 64-bit handshaking port. See the *Digital I/O Application Hints* section in Chapter 3, *Software Overview*, in the *NI-DAQ User Manual for PC Compatibles* for more details.

DIO-24, AT-MIO-16DE-10, and 6025E Devices

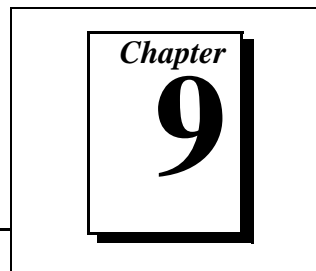

This chapter contains overview information on the DIO-24 (PC-DIO-24, PC-DIO-24PnP, DAQCard-DIO-24), AT-MIO-16DE-10, and 6025E digital I/O devices.

DIO-24, AT-MIO-16DE-10, and 6025E Digital I/O

The DIO-24, AT-MIO-16DE-10, and 6025E devices contain 24 bits of digital I/O. These bits are divided into a set of three digital I/O ports of eight bits each.

The digital I/O ports are labeled as ports PA, PB, and PC on the I/O connectors, as shown in your device user manual. You can configure all three ports as either input ports or output ports. Table 9-1 lists the port numbers to use in the digital I/O functions.

Table 9-1. Digital I/O Device Port Numbers

Device	Port Names	Port Numbers
DIO-24	PA, PB, PC	0, 1, 2
AT-MIO-16DE-10, 6025E devices	PA, PB, PC	2, 3, 4

Ports PA and PB support both handshaking and no-handshaking modes. You can use port PC for no-handshaking mode only. The device uses the digital lines making up port PC as handshaking lines for both ports PA and PB whenever you configure either for handshaking mode; therefore, port PC is not available for digital I/O functions whenever you configure either port PA or port PB for handshaking mode.



Note

As discussed in Chapter 1, MIO and AI Devices, the AT-MIO-16DE-10 and 6025E devices also contain eight additional bits of digital I/O called port 0. The AT-MIO-16DE-10 and 6025E devices do not have a port 1.

DIO-24, AT-MIO-16DE-10, and 6025E Device Groups

You can group ports PA and PB together to make up a 16-bit port. See *Digital I/O Application Hints* in Chapter 3, *Software Overview*, in the *NI-DAQ User Manual for PC Compatibles* for more details.

DIO-32F and DAQDIO 6533 (DIO-32HS) Digital I/O Devices

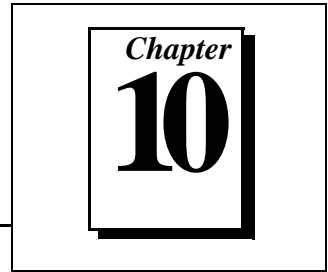

This chapter contains overview information on the DIO-32F and DAQDIO 6533 (DIO-32HS) digital I/O devices, including the AT-DIO-32F, AT-DIO-32HS, PCI-DIO-32HS, DAQCard-6533, DAQPad-6533, and PXI-6533.

DIO-32F and DAQDIO 6533 (DIO-32HS) Digital I/O Boards

The DIO-32F and DAQDIO 6533 (DIO-32HS) provide 32 bits of bidirectional I/O, in addition to extra input and output lines that differ from board to board.

The 32 bidirectional I/O lines are divided into four digital I/O ports of eight bits each. The 8-bit digital I/O ports are labeled DIOA, DIOB, DIOC, and DIOD. Refer to your device user manual for the locations of I/O lines on the I/O connector. The digital I/O functions refer to these ports, along with the extra input and output ports, by the numbers from 0 to 4:

- port DIOA = port 0
- port DIOB = port 1
- port DIOC = port 2
- port DIOD = port 3
- extra inputs and extra outputs = port 4

An AT-DIO-32F provides two extra dedicated input lines and two extra dedicated output lines. The extra inputs are labeled IN1 and IN2. The extra outputs are labeled OUT1 and OUT2. Refer to your device user manual for the locations of these lines on the I/O connector.

A DAQDIO 6533 (DIO-32HS) provides up to four extra input and four extra output lines, depending on the handshaking configuration you select. Any control lines unused in your handshaking configuration are available as extra input and output lines. You can use handshaking lines STOPTRIG1, STOPTRIG2, REQ1 and REQ2 as extra inputs, in which case they function as IN1 through IN4 lines. You can use handshaking

lines PCLK1, PCLK2, ACK1 and ACK2 as extra outputs, in which case they function as OUT1 through OUT4 lines. Refer to your hardware user manual for the locations of these lines on the I/O connector.

You can configure ports 0 through 3 for both handshaking and no-handshaking modes. To configure the ports for handshaking mode, you must assign the ports to one of two handshaking groups. The digital I/O connector has handshaking lines for the groups. These handshaking lines include the REQ1 and REQ2 lines for request, and the ACK1 and ACK2 lines for acknowledge. The DAQDIO 6533 (DIO-32HS) also has STOPTRIG1 and STOPTRIG2 for stop triggers, and PCLK1 and PCLK2 lines for clocks. Signals received or generated on the handshaking lines affect only the ports assigned to the group.

Port 4 is always configured as an I/O port. Writing to port 4 affects the extra output lines. Reading from port 4 returns the digital values of the extra input lines. Table 10-1 shows the lines that are mapped to the bits within the byte written to or read from port 4.

Table 10-1. DIO-32F Extra Inputs and Outputs

Bit Number	DIO-32F Line Used Input Operation	DIO-32F Line Used Output Operation	Restrictions
7 to 2	None	None	None
1	IN2	OUT2	None
0	IN1	OUT1	None

On a DAQDIO 6533 (DIO-32HS), when group 1 is configured for handshaking, you cannot use the group 1 handshaking lines as extra inputs or outputs. In this case, port 4 output operations have no effect on the ACK1 (OUT1) and PCLK1 (OUT3) lines. Port 4 input operations do not return valid data bits for the REQ1 (IN1) and STOPTRIG1 (IN3) lines. Similarly, when group 2 is configured for handshaking, you cannot use the group 2 handshaking lines as extra inputs or outputs.

Table 10-2. DAQDIO 6533 (DIO-32HS) Extra Inputs and Outputs

Bit Number	DAQDIO 6533 (DIO-32HS) Line Used Input Operation	DAQDIO 6533 (DIO-32HS) Line Used Output Operation	Restrictions
7 to 4	None	None	None
3	REQ2 (IN4)	ACK2 (OUT4)	Ignore this bit number if group 2 is configured for handshaking.
2	REQ1 (IN3)	ACK1 (OUT3)	Ignore this bit number if group 1 is configured for handshaking.
1	STOPTRIG2 (IN2)	PCLK2 (OUT2)	Ignore this bit number if group 2 is configured for handshaking.
0	STOPTRIG1 (IN1)	PCLK1 (OUT1)	Ignore this bit number if group 1 is configured for handshaking.

You cannot configure port 4 for handshaking mode.

**Note**

On the AT-DIO-32F at least one DMA channel must be available if you are to use buffered operations (DIG_Block and DIG_DB functions calls).

AMUX-64T External Multiplexer Device

Chapter

11

This chapter contains overview information on the AMUX-64T device.

AMUX-64T External Multiplexer Device

An AMUX-64T external multiplexer device expands the number of analog input signals that the MIO or AI device can measure. The AMUX-64T has 16 separate four-to-one analog multiplexer circuits. One AMUX-64T device can multiplex up to 64 analog input signals. You can cascade four AMUX-64T devices to permit up to 256 single-ended (128 differential) signals to be multiplexed by one MIO or AI device. Table 11-1 shows the number of channels available on the MIO or AI device with an external multiplexer.

Table 11-1. Analog Input Channel Range

Number of External Multiplexer (AMUX-64T) Devices	Channel Range	
	Single-Ended	Differential
0	0–15	0–7
1	0–63	0–31
2	0–127	0–31, 64–95
4	0–255	0–31, 64–95, 128–159, 192–223

`AI_Mux_Config` configures the number of multiplexer devices connected to the MIO or AI device. You then use the input channels in subsequent data acquisition calls with respect to the external AMUX-64T analog input channel numbers rather than the MIO or AI device onboard channel numbers. For example, with one external device, **channel** can have a value of 0 through 63 (single-ended), or 0 through 31 (differential). With two or four AMUX-64T devices, channel numbering of the second device can be from 64 through 127 (single-ended), or from 64 through 95 (differential).

Therefore, single-ended and differential channels always begin at the same number on each device.

When you use more than one AMUX-64T device, address the channels on the different devices, as shown in Table 11-2.

Table 11-2. AMUX-64T Channel Numbers

AMUX-64T Device	Channel Number	
	Single-Ended	Differential
Device A	0–63	0–31
Device B	64–127	64–95
Device C	128–191	128–159
Device D	192–255	192–223

The channel address on each AMUX-64T depends on the switch setting on each device. See the *AMUX-64T User Manual* for more information on the external multiplexer device.

Scanning Order Using the AMUX-64T

The scanning counters on the AMUX-64T and on the MIO or AI device perform automatic scanning of the AMUX-64T analog input channels. When you perform a multiple-channel scanned data acquisition with an AMUX-64T, one of the counter/timers on the MIO or AI device normally available to you. Counter 1, is used for switching the MIO or AI device onboard multiplexers.

Scanning is a simple operation for one AMUX-64T device but becomes more complex for multiple AMUX-64T devices. The following paragraphs explain in detail how channels are scanned from the AMUX-64T. You must know this scanning order so that you can determine from which analog input channel the data was scanned during a data acquisition operation. When a single AMUX-64T device is connected to the MIO or AI device, you must scan four AMUX-64T input channels for every MIO or AI device channel. If two AMUX-64T devices are attached to the MIO or AI device, you must scan eight AMUX-64T channels for every MIO or AI device input channel. For example, channels 0 through 3 on AMUX-64T device A and channels 64 through 67 on AMUX-64T device B are multiplexed

together into MIO or AI device channel 0. Notice that the MIO or AI device scans the first four channels on device A, followed by the first four channels on device B.

If four AMUX-64T devices are attached to the MIO or AI device, you must scan 16 AMUX-64T channels for every MIO or AI device input channel. For example, channels 0 through 3 on AMUX-64T device A, channels 64 through 67 on AMUX-64T device B, channels 128 through 131 on AMUX-64T device C, and channels 192 through 195 on device D are multiplexed together into MIO or AI device channel 0. Notice that the MIO or AI device scans the first four channels on device A, followed by the first four channels on device B, the first four channels on device C, and, finally, the first four channels on device D.

The order in which the MIO or AI device scans channels depends on the scan channel sequence specified in `SCAN_Setup`. This scan sequence is an array of MIO or AI device onboard channel numbers that indicates the order in which the MIO or AI device onboard channels are scanned. The scanning order on the AMUX-64T, however, is fixed. Table 11-3 shows the order in which the AMUX-64T channels are scanned for every MIO or AI device input channel for different AMUX-64T configurations.

Table 11-3. AMUX-64T Scanning Order for Each MIO or AI Device Input Channel

MIO or AI Device Channel	AMUX-64T Channels						
	One Device	Two Devices		Four Devices			
	Device A	Device A	Device B	Device A	Device B	Device C	Device D
0	0–3	0–3	64–67	0–3	64–67	128–131	192–195
1	4–7	4–7	68–71	4–7	68–71	132–135	196–199
2	8–11	8–11	72–75	8–11	72–75	136–139	200–203
3	12–15	12–15	76–79	12–15	76–79	140–143	204–207
4	16–19	16–19	80–83	16–19	80–83	144–147	208–211
5	20–23	20–23	84–87	20–23	84–87	148–151	212–215
6	24–27	24–27	88–91	24–27	88–91	152–155	216–219
7	28–31	28–31	92–95	28–31	92–95	156–159	220–223

Table 11-3. AMUX-64T Scanning Order for Each MIO or AI Device Input Channel (Continued)

MIO or AI Device Channel	AMUX-64T Channels						
	One Device	Two Devices		Four Devices			
	Device A	Device A	Device B	Device A	Device B	Device C	Device D
8	32–35	32–35	96–99	32–35	96–99	160–163	224–227
9	36–39	36–39	100–103	36–39	100–103	164–167	228–231
10	40–43	40–43	104–107	40–43	104–107	168–171	232–235
11	44–47	44–47	108–111	44–47	108–111	172–175	236–239
12	48–51	48–51	112–115	48–51	112–115	176–179	240–243
13	52–55	52–55	116–119	52–55	116–119	180–183	244–247
14	56–59	56–59	120–123	56–59	120–123	184–187	248–251
15	60–63	60–63	124–127	60–63	124–127	188–191	252–255

For example, if you use one AMUX-64T device, whenever NI-DAQ selects channel 0 on the MIO or AI device in the scan sequence, channels 0 through 3 on the AMUX-64T are automatically scanned. If you use two AMUX-64T devices, channels 0 through 3 (device A) and channels 64 through 67 (device B) are automatically scanned whenever channel 0 is selected in the scan sequence. If you use four AMUX-64T devices, channels 0 through 3 (device A), channels 64 through 67 (device B), channels 128 through 131 (device C), and channels 192 through 195 (device D) are automatically scanned whenever channel 0 is selected in the scan sequence.

If you program the MIO or AI device with a sequential channel scan sequence of 0 through 7 or 0 through 15, the AMUX-64T channels are scanned from top to bottom in the order given in Table 10-3. Notice that if you use differential input configuration, you should enter only MIO or AI device channels 0 through 7 in the scan sequence in `SCAN_Setup`, in which case only the information pertaining to those channels in Table 11-3 applies. See the *AMUX-64T User Manual* for more information on the external multiplexer device.

**Note**

The MIO-64 devices have onboard analog input channels that are numbered as follows:

0 through 63, in single-ended mode

0 through 7, 16 through 23, 32 through 39, and 48 through 55, in differential mode

If you plan to use the AMUX-64T with any of these boards, the AMUX-64T channel numbers overlap with the onboard channels. For example, if you have one AMUX-64T device connected to the AT-MIO-64E-3, AMUX-64T channels 16 through 63 conflict with onboard single-ended channels (with the same numbers) on the analog input connector. Because of this overlapping of channel numbers, you must call the `MIO_Config` function whenever you want to use an AMUX-64T channel. For further details on the `MIO_Config` function, refer to Chapter 2, Function Reference, of the NI-DAQ Function Reference Manual for PC Compatibles.

If you are using your MIO or AI device to power the AMUX-64T, you must be aware that not only must the fuses on the AMUX-64T be intact, but the fuse on the MIO or AI device must also work. All fuses are in working order when you receive them, but inadvertent contact between +5 V and ground can short the fuse.

SC-204X Devices

A graphic consisting of a black-bordered square. Inside the square, the word "Chapter" is written in a serif font at the top. Below it, the number "12" is written in a large, bold, black serif font.

This chapter contains overview information on the SC-2040, SC-2042-RTD, and SC-2043-SG.

SC-2040 Track-and-Hold Accessory

The SC-2040 simultaneously amplifies and samples up to eight differential inputs and sends them in parallel as differential signals to an E Series DAQ device. The SC-2040 has eight amplifiers, each with a DIP-switch programmable gain of 1, 10, 100, 200, 300, 500, 600, 700, or 800. The SC-2040 can be powered from either the DAQ device or from an external 5 V power supply. Scanning of the SC-2040 channels can be initiated through software or through an external trigger.

The track-and-hold circuitry acquires signals within 7 μ s, and when hold mode is enabled, the signals settle within 1 μ s. Then the E Series device samples the SC-2040 channels as fast as possible, after which the SC-2040 is put into track mode again.

If you have configured your SC-2040 in the Measurement & Automation Explorer, you do not have to call `SC_2040_Configure` because NI-DAQ will retrieve the SC-2040 settings from the configuration file.

To take a single snapshot of voltages from several channels, you use the `SCAN_Setup` function followed by either `AI_Read_Scan` or `AI_VRead_Scan`. To scan a group of channels repeatedly, use the `SCAN` functions.

SC-2042-RTD Accessory

The SC-2042-RTD is a low-cost input device that connects directly to RTDs and provides current source excitation and RTD input signal routing to the Lab and 1200 Series devices, and the MIO and AI E Series devices. The SC-2042-RTD has eight channels, each of which has one current excitation source (1 mA) and differential input signal routing to the DAQ device. The SC-2042-RTD works with RTDs from 10 Ω to 2 k Ω over their full temperature range, 4-wire ohms measurements of up to 6 k Ω , and overvoltage protection of 25 VDC.

To use the SC-2042-RTD, you must configure your DAQ device for differential mode.

SC-2043-SG Accessory

The SC-2043-SG is a low-cost input device for bridge completion and calibration of strain gauge bridge circuits and input signal routing to the Lab and 1200 Series devices, and the MIO and AI E Series devices. The SC-2043-SG has eight channels; each channel has one-quarter or one-half (and full) bridge completion, a bridge-balancing circuit, and nonreferenced single-ended input signal routing to the DAQ device. There is one half-bridge reference common to all channels, with a jumper disable for full-bridge connections. The excitation supply is external and is common to all channels.

If you have configured your device in the Measurement & Automation Explorer, you do not have to call `Set_DAQ_Device_Info` because NI-DAQ will retrieve the SC-2043-SG settings from the configuration file.

Configure your DAQ device for NRSE mode to use the SC-2043-SG.

SCC Series Devices

A graphic for Chapter 13, featuring the word "Chapter" in a serif font above the large number "13", all enclosed in a rectangular frame with a drop shadow effect.

This chapter contains overview information on SCC devices.

SCCs are Signal Conditioning Components you use with a shielded carrier that connects to your 68-pin E Series device for conditioning I/O signals on a per channel basis. Currently, SCC components are available for voltage attenuation, 0-20 mA current input, thermocouple inputs, and breadboarding.

SCC Shielded Carrier

The SC-2345 is a shielded carrier for SCCs that connects directly to 68-pin E Series DAQ devices. The SC-2345 includes sockets for SCC components, along with a screw terminal block for convenient connection to digital and counter/timer (GPCTR) signals of the E Series DAQ device. The SC-2345 is available with three power options.

The SC-2345 includes 20 SCC sockets, J1-J20. Sockets J1-8 accommodate SCC components for conditioning the analog input channels of the E Series DAQ device. Sockets J9-16 are used for dual-stage conditioning of analog input channels. Alternatively, sockets J9-16 can be used to access the eight digital I/O (DIO) lines of the E Series DAQ device using either an SCC-FT01 feed-through/breadboard component or future digital SCC components. DIO lines are also accessible via the screw terminal block. Likewise, sockets J17-18 access the two analog output channels and sockets J19-20 access the two GPCTR channels.

The SC-2345 carrier includes a 42-position screw terminal block for simple access to digital lines of the E Series DAQ device, including DIO (0-7), PFI (0-9), GPCTR, +5 V, DGND, AISENSE, FREQ_OUT, EXTSTROBE, and SCANCLK.

The SC-2345 is available with three power options. Each SC-2345 kit includes a power module that supplies digital power (+5 VDC) and analog power (± 15 V) to each SCC component. With the SCC-PWR01, you can power the SC-2345 and SCC components either with +5 VDC from the DAQ device or from an external 5 V source. If external 7-42 VDC power is

preferred, you can use the SCC-PWR03 option. Finally, for high-power requirements (>2 W), you can use the SCC-PWR02 option.

SCC Series Components

SCCs are available for voltage attenuation, current input, and thermocouple input to your E Series device. A feed-through SCC allows direct connection to the analog input or analog output signals. You can customize this feed-through SCC to meet your specific signal conditioning needs by adding your circuit design inside the feed-through component.

SCC-A10 Voltage Attenuator Module

The SCC-A10 is a dual-channel module that accepts input voltage sources up to 100 V. Each channel of the SCC-A10 includes a divide-by-10 attenuation circuit and a differential instrumentation amplifier with low-impedance outputs for maximum scanning rates by the DAQ device.

SCC-CI20 Current Input Module

The SCC-CI20 is a dual-channel module that accepts 0-20 mA current inputs. Each channel of the SCC-CI20 includes a precision $249\ \Omega$ current conversion resistor that converts a 0-20 mA signal to a 0-5 V signal and a differential instrumentation amplifier with low-impedance outputs for maximum scanning rates by the DAQ device.

SCC-TC01/02 Thermocouple Input Modules

The SCC-TC01 and SCC-TC02 are single-channel modules for conditioning a variety of thermocouple types including J, K, B, E, N, R, S, and T, and millivolt inputs with a range of ± 100 mV. The SCC-TC modules include an onboard thermistor for cold-junction compensation. The SCC-TC01 includes a two-prong uncompensated thermocouple miniconnector that accepts any miniature or subminiature two-prong male thermocouple connector. The SCC-TC02 includes a removable screw terminal plug that includes an additional connection for grounding thermocouple shields.

SCC-FT01 Feed-Through/Breadboard Module

The SCC-FT01 is a feed-through module that offers direct connection to analog input or output channels of the E Series DAQ device. The SCC-FT01 includes breadboard area for development of custom signal conditioning circuitry for analog input, analog output, digital I/O, and GPCTR channels of the E Series DAQ device.

SCC Configuration

You must configure your SCC carrier and modules with the Measurement & Automation Explorer. NI-DAQ will retrieve the SCC settings from the configuration file.

Configure your DAQ device for NRSE mode to use the SCC components.

SCXI Hardware

Chapter 14

This chapter contains overview information on SCXI hardware. The information in this chapter is modified by information in the VXI-DAQ Signal Conditioning section of the VXI-DAQ chapter and the SCXI section of the PXI chapter.



Note

In this chapter, the term “Lab and 1200 Device” does not include the DAQPad-1200.

SCXI modules provide signal conditioning for analog input signals, isolation for analog and digital I/O signals, and channel multiplexing to increase the number of analog and digital signals provided by a DAQ device. You connect signals to your SCXI modules using shielded SCXI terminal blocks that plug into the front of the modules.

You can use a plug-in DAQ device in your computer to control the SCXI modules and perform A/D conversions on the conditioned analog input signals. You use an SCXI ribbon cable assembly to connect one of the SCXI modules in your chassis to the plug-in DAQ device in your PC.

You also can use the SCXI-1200 data acquisition and control module in your SCXI chassis to control the other SCXI modules and perform A/D conversions remotely at the SCXI chassis. NI-DAQ uses either the parallel port on your PC to communicate with the SCXI-1200 or the serial port on your PC to communicate with the remote SCXI unit that houses the SCXI-1200. You do not need to cable anything to other modules in the chassis.

NI-DAQ supports the following DAQ devices for use with non-remote SCXI:

- Lab and 1200 Devices (except for the DAQPad-1200)
- DIO-24
- DIO-32F
- DIO-96
- MIO and AI devices (except DAQPad devices)

Please refer to the *SCXI Modules and Compatible DAQ Devices* section later in this chapter for information about the functionality of each DAQ device with each type of SCXI module.

SCXI Installation and Configuration

To install your SCXI system, follow the instructions in your SCXI hardware manual. After you assemble your SCXI system, you must run the Measurement & Automation Explorer to enter your SCXI configuration; NI-DAQ needs the configuration information to program your SCXI system correctly. The Measurement & Automation Explorer online help contains instructions for entering your SCXI configuration.

SCXI Operating Modes

The way that NI-DAQ has access to the signals from the modules depends on the operating modes of the modules. There are two basic operating modes for SCXI modules—multiplexed and parallel. The operating mode is a parameter that you enter in the configuration utility.



Note

It is recommended that you use the multiplexed mode.

Multiplexed Mode for Analog Input Modules

When an analog input module operates in multiplexed mode, all of its input channels are multiplexed to one module output. When you cable a DAQ device to a multiplexed analog input module, the DAQ device has access to that module's multiplexed output, as well as the outputs of all other multiplexed modules in the chassis via the SCXIbus. The SCXI functions route the multiplexed analog signals on the SCXIbus for you transparently. So, if you operate all modules in the chassis in multiplexed mode, you only need to cable one of the modules directly to the DAQ device.

The module you cable to the DAQ device must be an analog input module. Only analog input modules can route the analog signal from the SCXI bus to the DAQ device. You can use the SCXI-1340 cable assembly to connect an MIO or AI device directly to an analog input module in a non-remote SCXI configuration. You must use the SCXI-1341 cable assembly for a Lab-PC+, PCI-1200, Lab-PC-1200, Lab-PC-1200AI or DAQCard-1200. You cannot cable a DIO board to an analog input module. If you are using multiple analog input modules in multiplexed mode, you only need to cable

one of the modules in each chassis to the DAQ device, or you can control the modules using the SCXI-1200 DAQ module.

If you use the SCXI-1200 DAQ module in multiplexed mode, it also has access to the multiplexed output of all analog input modules in the chassis that are operated in multiplexed mode.

If you use an MIO or AI device, Lab or 1200 device (except for the DAQPad-1200), or an SCXI-1200 DAQ module, you can multiplex all the analog input channels in the SCXI chassis to one onboard channel *dynamically during a timed acquisition*. The SCXI functions program the chassis with a module scan list that dynamically controls which module sends its output to the SCXIbus during a scan. You can specify that the modules be scanned in any order and specify an arbitrary number of channels for each module; however, the channels on each module must be scanned in consecutive, ascending order.

By default, when you cable a DAQ device to a multiplexed module, the multiplexed output of the module (and all other multiplexed modules in the chassis) appears at analog input channel 0 of the DAQ device.

You can use more than one SCXI chassis connected by a ribbon cable with one MIO or AI device (except parallel ports) if the modules operate in multiplexed mode. You must use one SCXI-1350 multichassis adapter for each additional chassis (refer to your SCXI module user manuals). You also should set a unique address for each chassis. The multichassis adapter scheme sends the output of the module in the first chassis to analog input channel 0 of the MIO or AI device, the output of the module in the second chassis to analog input channel 1 of the MIO or AI device, and so on. When you want to acquire data from the additional chassis, you must specify the correct onboard MIO or AI device channel in the channel scan list that you pass to the SCAN functions.

You can operate the SCXI-1100, SCXI-1101, SCXI-1102, and SCXI-1122 modules only in multiplexed mode.

Multiplexed Mode for the SCXI-1200

In multiplexed mode, the SCXI-1200 can access the analog bus on the SCXI backplane. When you configure other analog input modules in the chassis for multiplexed mode, the SCXI functions can multiplex their input channels and send them on the analog bus on the SCXI backplane. So, if you configure the SCXI-1200 for multiplexed mode, you can use it to read the multiplexed output from other SCXI analog input modules in the

chassis. In addition, you can multiplex the analog input channels on the SCXI-1200 with the input channels from other analog input modules in the chassis during the same scanning operation.

You cannot use the SCXI-1200 to read channels from other analog input modules that are configured for parallel mode.

Multiplexed Mode for Analog Output Modules

The SCXI-1124 analog output module supports only multiplexed mode (sometimes referred to as *serial mode* in the *SCXI-1124 User Manual*). This means that NI-DAQ sets the analog output channel states by communicating serially over the SCXIBus. Because NI-DAQ can communicate with the multiplexed modules over the SCXIBus backplane, you only need to cable one multiplexed module in each chassis directly to a DAQ device in the computer, or you can use the SCXI-1200 DAQ module to communicate with all other multiplexed modules in the chassis.

Multiplexed Mode for Digital and Relay Modules

Multiplexed mode is referred to as serial mode in the digital and relay module hardware manuals. When you operate your digital or relay module in multiplexed (or serial) mode, NI-DAQ communicates the module channel states serially over the SCXIBus backplane. The SCXI-1162, SCXI-1162HV, SCXI-1163, and SCXI-1163R modules have jumpers that you must set correctly for the module to operate in multiplexed (or serial) mode. Because NI-DAQ can communicate with the multiplexed modules over the SCXIBus backplane, you only need to cable one multiplexed module in each chassis directly to a DAQ device in the computer, or you can use the SCXI-1200 DAQ module to communicate with all other multiplexed modules in the chassis.

Parallel Mode for Analog Input Modules

When an analog input module operates in parallel mode, it sends each of its input channels directly to a separate analog input channel of the DAQ device cabled to the module. You cannot multiplex parallel outputs of a module on the SCXIBus; only a DAQ device that you cable directly to a module in parallel mode has access to its input channels. In this configuration, the total number of analog input channels is limited to the number of channels available on the DAQ device. In some cases, however, you can cable more than one DAQ device to modules in an SCXI chassis. For example, you can use two Lab-PC+ boards and cable each one to a separate SCXI-1120 module in the chassis operating in parallel mode. You

must be sure to enter the correct device numbers in the **Connected to** field of the Measurement & Automation Explorer for each module you operate in parallel mode.

By default, when a module operates in parallel mode, the module sends its channel 0 output to analog input channel 0 of the DAQ device, the channel 1 output to analog input channel 1 of the DAQ device, and so on. You cannot use an SCXI-1200 to read channels from another analog input module in parallel mode.

Parallel (or Standalone) Mode for the SCXI-1200

In parallel mode, the SCXI-1200 can read only its own analog input channels. The SCXI-1200 does not have access to the analog bus on the SCXI backplane if you configure it for parallel mode. You should use parallel mode if you are not using other SCXI analog input modules in the chassis in addition to the SCXI-1200.

Parallel Mode for Digital Modules

When you operate a digital module in parallel mode, the digital lines on your DAQ device directly drive the individual digital channels on your SCXI module. You must cable a separate DAQ device directly to every module that you operate in parallel mode. The SCXI-1162, SCXI-1162HV, SCXI-1163, and SCXI-1163R modules have jumpers that you must set correctly for the module to operate in parallel mode. Only the DIO boards, AT-MIO-16DE-10, and the 6025E devices can use the digital modules in parallel mode. The MIO or AI devices and the Lab and 1200 devices cannot use the digital modules in parallel mode.

You might want to use parallel mode instead of multiplexed mode for faster updating or reading of the SCXI digital channels. For the fastest performance in parallel mode, you can use the Digital I/O functions described in Chapter 3, *Software Overview*, of the *NI-DAQ User Manual for PC Compatibles* with the appropriate onboard port numbers instead of using the SCXI functions. Refer to the *SCXI Modules and Compatible DAQ Devices* section later in this chapter for information about which digital ports on each DAQ device are actually used in parallel mode.



Note

A DAQ device that is cabled to an SCXI-1162, SCXI-1162HV, SCXI-1163, and SCXI-1163R in parallel mode cannot be the communication path in the Measurement & Automation Explorer.

If you are using a DIO-96, AT-MIO-16DE-10, or 6025E device, you can also operate a digital module in parallel mode using the digital ports on the second half of the ribbon cable (pins 51–100). So, the DIO-96 can operate two digital modules in parallel mode—one module using the first half of the ribbon cable (pins 1–50) and another module using the second half of the ribbon cable (pins 51–100). Set the operating mode in the Measurement & Automation Explorer to **parallel (secondary)** for the module that will use the second half of the ribbon cable.

SCXI Modules and Compatible DAQ Devices

The capabilities and limitations described in this section should help you determine how your hardware components can work together in your application and help you determine the best SCXI configuration for your application. Please refer to your SCXI module and chassis user manuals and DAQ device user manuals for detailed information about the capabilities and limitations of your hardware.

SCXI-1100

The SCXI-1100 module has 32 differential analog input channels. The input voltage range is -10 to $+10$ V. The SCXI-1100 has a software-selectable module gain with values of 1, 2, 5, 10, 20, 50, 100, 200, 500, 1,000, and 2,000. The gain applies to all channels on the module; use the `SCXI_Set_Gain` function to select the module gain. The gain fields in the Measurement & Automation Explorer are not used by NI-DAQ; those fields are used only by LabVIEW. The SCXI-1100 also has a software-selectable Calibration mode that you can use to determine the zero offset of the module (see the `SCXI_Calibrate_Setup` function description).

The SCXI-1300 and SCXI-1303 terminal blocks that you can use with the SCXI-1100 module each have an onboard temperature sensor that is jumper configurable to be either multiplexed with the other input channels (MTEMP configuration), or to be sent directly to a different DAQ device channel (DTEMP configuration). In the MTEMP configuration, you can select the temperature sensor in software using the `SCXI_Single_Chan_Setup` function. If you use the DTEMP configuration, the temperature sensor output appears on DAQ device channel 1. When you use the SCXI-1300, multiply the voltage you read from the temperature sensor by 100 to get degrees Celsius. The SCXI-1303 temperature sensor is a thermistor; you can use the thermistor conversion routine described in *The Transducer Conversion Functions*

section in Chapter 3, *Software Overview*, of the *NI-DAQ User Manual for PC Compatibles* to convert the thermistor voltage to temperature.

Please refer to the *SCXI-1100 User Manual* for more information on the hardware-selectable signal conditioning features on the module.

The SCXI-1100 supports the multiplexed operating mode only; it does *not* support parallel mode.

SCXI-1101

The SCXI-1101 has 32 differential analog input channels and one cold-junction sensor channel (CJTEMP) that is selectable through the `SCXI_Single_Chan_Setup` function. When you use this module with an SCXI-1300, SCXI-1303, or SCXI-1311 terminal block, the terminal block temperature sensor connects to CJTEMP; the sensor on the SCXI-1311 has a voltage range of -0.2 to $+0.2$ V and on the other terminal blocks, a range of -2 to $+2$ V. The module can multiplex CJTEMP with the other 32 input channels during a hardware-controlled scan. All channels have a fixed gain of 1. Channels on the SCXI-1101 can be scanned in any order, except for the CJTEMP channel which has to be the first channel in a scan.

The SCXI-1101 supports the multiplexed operating mode only; it does *not* support parallel mode.

SCXI-1102

The SCXI-1102 has 32 differential analog input channels and one cold-junction sensor channel (CJTEMP) that is selectable through the `SCXI_Single_Chan_Setup` function. When you use the module with an SCXI-1300 or SCXI-1303 terminal block, the terminal block temperature sensor connects to CJTEMP. The module can multiplex CJTEMP with the other 32 input channels during a hardware-controlled scan. On each channel, including CJTEMP, the SCXI-1102 has a 3-pole low-pass filter with a 3 Hz cutoff frequency to reject 60 Hz noise. Each of the 32 differential analog input channels (but not CJTEMP) also has an amplifier with a selectable gain of 1 or 100, selected through the `SCXI_Set_Gain` function. The amplification and filtering occur before multiplexing.



Note

When you change the gain on a channel, the output will take several seconds to settle. The module contains a Status Register to indicate that the output is in the process of settling, and this information is available to applications through the `SCXI_Get_Status` function.

The SCXI-1102 supports multiplexed operating mode only; it does *not* support parallel mode.

SCXI-1102B and the SCXI-1102C

The SCXI-1102B and the SCXI-1102C are variants of the SCXI-1102. They are functionally identical to the SCXI-1102 except for their higher bandwidth support: 200 Hz for SCXI-1102B and 10 kHz for the SCXI-1102C, as compared to the 2 Hz bandwidth limitation for the SCXI-1102.

SCXI-1120, SCXI-1120D, and SCXI-1121

The SCXI-1120, SCXI-1120D, and SCXI-1121 are 8-channel and 4-channel isolation modules, respectively. The input voltage range on all three modules is ± 5 V. The modules have a hardware-selectable gain on each input channel with values of 1, 2, 5, 10, 20, 50, 100, 200, 500, 1,000, and 2,000 for the SCXI-1120 and SCXI-1121. The hardware-selectable gain on each input channel for the SCXI-1120D have values of 0.5, 1, 2.5, 5, 10, 25, 50, 100, 250, 500, 1000. The gain fields in the Measurement & Automation Explorer are not used by NI-DAQ; those fields are used only by LabVIEW. You use the `SCXI_Scale` function to compensate for SCXI-1120, SCXI-1120D, and SCXI-1121 gains. The SCXI-1121 also has four excitation channels that you can use for voltage or current excitation.

The SCXI-1305 AC/DC Coupling BNC Terminal Block works with the SCXI-1120, SCXI-1120D, SCXI-1121, SCXI-1140, and SCXI-1141. The maximum common mode voltage is limited to 42 V peak or DC with the SCXI-1120, SCXI-1120D, and SCXI-1121.

The SCXI-1320 and SCXI-1328 terminal blocks that you can use with the SCXI-1120, SCXI-1120D, and SCXI-1121 modules each have an onboard temperature sensor that is jumper-configurable to be either multiplexed with the other input channels in multiplexed mode (MTEMP configuration), or to be sent directly to a different DAQ device channel (DTEMP configuration). In the MTEMP configuration, you can select the temperature sensor in software using the `SCXI_Single_Chan_Setup` function. If you use the DTEMP configuration, the temperature sensor output appears on DAQ device channel 15 for the SCXI-1120/D, and channel 4 for the SCXI-1121. To read the temperature sensor in the DTEMP configuration with the SCXI-1120/D, the DAQ device must be in NRSE mode. When you use the SCXI-1320, multiply the voltage you read from the temperature sensor by 100 to get degrees Celsius. The SCXI-1328 temperature sensor is a thermistor; you can use the thermistor conversion

routine described in *The Transducer Conversion Functions* section in Chapter 3, *Software Overview*, of the *NI-DAQ User Manual for PC Compatibles* to convert the thermistor voltage to temperature.

You can use the SCXI-1321 terminal block only with the SCXI-1121 (Revision C and later). In addition to the features of SCXI-1320, the SCXI-1321 also has shunt resistors that you can enable using the `SCXI_Calibrate_Setup` function to check your bridge circuit. The SCXI-1327 terminal block has DIP switch configurable attenuators that can divide the input signals applied to the SCXI-1120 or SCXI-1121 by 100. You use the `SCXI_Scale` function to compensate for the attenuation when you scale your binary data to voltage.

Please refer to the SCXI-1120, SCXI-1120D, and SCXI-1121 user manuals for information on the hardware-selectable signal conditioning features available on the modules.

The SCXI-1120, SCXI-1120D, and the SCXI-1121 modules support both multiplexed and parallel operating modes.

SCXI-1122

The SCXI-1122 has 16 differential analog input channels. The input voltage range is -5 to $+5$ V. The SCXI-1122 has a software-selectable gain that applies to all channels on the module; use the `SCXI_Set_Gain` function to program the module gain. The gain fields in the Measurement & Automation Explorer are not used by NI-DAQ; those fields are used only by LabVIEW. This module also has a programmable low-pass filter with cut-off frequencies of 4 Hz and 4 kHz. Use the `SCXI_Configure_Filter` function to select the filter setting.

The SCXI-1122 supports multiplexed mode only; it does not support parallel mode.

The SCXI-1322 terminal block that can be used with the SCXI-1122 has an onboard thermistor that you can use to do cold-junction compensation for temperature readings; use the `SCXI_Single_Chan_Setup` function to select the sensor for reading. You can use the thermistor conversion routine described in *The Transducer Conversion Functions* section in Chapter 3, *Software Overview*, of the *NI-DAQ User Manual for PC Compatibles* to convert the thermistor voltage to temperature.

If you are measuring RTDs, you can configure the SCXI-1122 for four-wire scanning mode, which means that the module will switch the current excitation source to drive one of the channels 8 through 15 as an excitation output channel whenever the corresponding input channel 0 through 7 is selected. In this mode the module has 8 analog input channels and 8 corresponding current excitation channels. See the `SCXI_Set_Input_Mode` function description in Chapter 2, *Function Reference*, of the *NI-DAQ Function Reference Manual for PC Compatibles*.

The SCXI-1122 uses relays to switch the input channels; these relays require 10 ms to switch. As a result, you cannot use a sampling rate greater than 100 Hz in a channel-scanning operation. In addition, the relays have a finite lifetime. If you plan to take many samples from each channel and average them to eliminate noise, you should use the single-channel or software scanning applications described in the *SCXI Application Hints* section in Chapter 3, *Software Overview*, of the *NI-DAQ User Manual for PC Compatibles*. This means you should select one channel on the module, acquire many samples from that channel, then select the next channel, and so on. You should not use the channel-scanning method if you want to take many samples from each channel and average them.

The SCXI-1122 has an onboard EEPROM which contains a set of factory calibration constants for the amplifier on the module. NI-DAQ automatically reads these constants and uses them in the `SCXI_Scale` function to compensate for amplifier gain and offset errors when scaling binary data to voltage. You can also perform your own module calibration by taking readings and using the `SCXI_Cal_Constants` function to store your own calibration constants in the EEPROM.

The SCXI-1122 has two software-selectable calibration modes that you use the `SCXI_Calibrate_Setup` function to select. You can ground the module amplifier inputs so that you can read the amplifier offset. You can also switch a shunt resistor across your bridge circuit to test your circuit (refer to the *SCXI-1122 User Manual* for more information about the shunt resistor).

SCXI-1124

The SCXI-1124 is a 6-channel analog output module capable of generating voltages between -10 and $+10$ V or currents between 0 and 20 mA. The SCXI-1124 has six independent 12-bit DACs. Each DAC channel has a software-selectable voltage or current output range. Use the `SCXI_AO_Write` function to set the output range and write voltages,

currents, or binary values to the DACs. The SCXI-1124 is designed for single-point output operations rather than waveform generation.

The SCXI-1124 has an onboard EEPROM which contains a set of factory calibration constants for each DAC. NI-DAQ automatically loads these constants so that the `SCXI_AO_Write` function can compute the 12-bit binary pattern needed to produce your desired voltage at the output. You can also compute your own calibration constants by writing binary values to the DACs, measuring the output voltage with a voltmeter, and using the `SCXI_Cal_Constants` function to calculate and store the constants in the module EEPROM.

The SCXI-1124 supports multiplexed mode only. You can cable an MIO or AI device, Lab-PC-1200, Lab-PC-1200AI, Lab-PC+, PCI-1200, or DAQCard-1200 to the SCXI-1124, in which case you should set the jumpers on the module for MIO operation. You can cable a DIO board to the SCXI-1124, in which case you should set the jumpers on the module for DIO operation. If there is another module in the chassis cabled to a DAQ device in multiplexed mode or if there is an SCXI-1200 module in the chassis, you do not need to cable the SCXI-1124 to anything; NI-DAQ will communicate with the module using the SCXIBus backplane. In this case, the MIO/DIO jumpers on the module are irrelevant. If you plan to use analog input SCXI modules in addition to the SCXI-1124, and you are not using an SCXI-1200 DAQ module, you should cable one of the analog input modules to the DAQ device.

If you are using remote SCXI, you can use the SCXI-1124 with or without the SCXI-1200 DAQ module, because NI-DAQ will communicate with the SCXI-1124 via the backplane and through the serial port cable.

SCXI-1126

The SCXI-1126 is an 8-channel frequency input module that supports input range of 250 Hz, 500 Hz, 1 kHz, 2 kHz, 4 kHz, 8 kHz, 16 kHz, 32 kHz, 64 kHz, and 128 kHz. All conversions between voltages and frequencies are handled by NI-DAQ, so when you use the `SCXI_Scale` function, frequency data is returned automatically. There are four programmable filter settings that can be selected through the `SCXI_Configure_Filter` function: 1 Hz, 40 Hz, 320 Hz, and 1 kHz. You use the `SCXI_Set_Threshold` function to select the level and offset for a hysteresis setting.

The SCXI-1126 has an onboard EEPROM which contains a set of factory calibration constants for the amplifier on the module. NI-DAQ

automatically reads these constants and uses them in the `SCXI_Scale` function to compensate for amplifier gain and offset errors when scaling binary data to frequency. You can also perform your own module calibration by taking readings and using the `SCXI_Cal_Constants` function to store your own calibration constants in the EEPROM.

You can use the SCXI-1327, SCXI-1305, SCXI-1328, TBX-1328, and TBX-1329 terminal blocks with the SCXI-1126. The SCXI-1126 module supports both multiplexed and parallel operating modes.

SCXI-1140

The SCXI-1140 is an 8-channel simultaneously sampling differential amplifier module. The input voltage range of the module is -10 to $+10$ V. It has a hardware-selectable gain on each input channel with values of 1, 10, 100, 200, and 500. The gain fields in the Measurement & Automation Explorer are not used by NI-DAQ; those fields are used only by LabVIEW. You use the `SCXI_Scale` function to compensate for SCXI-1140 gains. The SCXI-1140 module supports both multiplexed mode and parallel mode.

The SCXI-1140 simultaneously samples all the input signals and holds those values while the DAQ device reads the desired channels one by one. When the module is holding the input channel values, it is in *hold mode*; when it comes out of hold mode so that it can sense the new values on the input channels, it is in *track mode*. A control signal on the module determines when the module is in track mode and when the module will go into hold mode. This signal is derived either from a counter/timer output on the DAQ device, from an external source connected to a pin on the front connector of the module, or from a trigger line on the SCXIBus.

The SCXI-1140 track/hold setup is software-configurable for single-channel operations or for interval-scanning operations. During single-channel operations, an `SCXI` function call can put the module into hold mode before `AI` functions acquire the data, and put the module back into track mode to sense new input values. During interval-scanning operations, the scan interval timer causes the module to go into hold mode at the beginning of each scan and go back into track mode at the end of each scan. Effectively, the input channels of the SCXI-1140 are *simultaneously sampled* at the beginning of each scan. The scan interval timer can either be a counter on the DAQ device or an external source connected to the front connector of the module.

In addition, you can synchronize multiple SCXI-1140 modules by using the SCXIbus so that all SCXI-1140 modules will go into hold mode at the same time. If you are scanning multiple SCXI-1140 modules in multiplexed mode along with other types of SCXI modules, the module that is cabled to the DAQ device must be an SCXI-1140 module for the track/hold control signals to be properly routed and synchronized.

It is important to be aware of the track/hold timing requirements of the SCXI-1140. For accurate data, the module must be in track mode for at least 7 μ s before going into hold mode. During an interval-scanning operation, this means that the scan interval should be at least 7 μ s longer than the total sample interval. After the module is in hold mode, the latched data at the input channels will droop at a rate of 10 mV/s, so you must be careful to sample all the desired channels relatively quickly after putting the module into hold mode.

SCXI-1141

The SCXI-1141 is an 8-channel analog input module with programmable gains and filters. The input range of the module is -5 to $+5$ V. It has programmable gains on each channel of 1, 2, 5, 10, 20, 50, and 100; use the `SCXI_Set_Gain` function to program the gain on a per-channel basis. The filters have a programmable cutoff frequency from 10 Hz to 25 kHz, and this frequency can be derived from an external clock; use the `SCXI_Configure_Filter` function to select the filter settings for the module or to enable the filters on a per-channel basis. The SCXI-1141 supports both multiplexed and parallel mode.

The SCXI-1141 has a software-selectable calibration mode that you can select with the `SCXI_Calibrate_Setup` function. You can ground each input of each amplifier so that you can read the amplifier offsets. The SCXI-1141 also has an onboard EEPROM that contains a set of factory gain adjustment calibration constants for each amplifier on the module. NI-DAQ automatically reads these constants and uses them in the `SCXI_Scale` function to compensate for amplifier gain errors when scaling binary data to voltage data. You also can perform your own amplifier calibration by taking readings and using the `SCXI_Cal_Constants` function to store your own calibration constants in the EEPROM.

The SCXI-1304 terminal block provides either AC or DC coupling of input signals. This terminal block also has a ground reference for floating signals.

SCXI-1160 and SCXI-1161

The SCXI-1160 is a 16-channel power relay module with 16 independent one-form C relays. The relays are latched—the module powers up with its relays in the position in which they were left at power down. You can set or reset each relay without affecting the other relays, or all relays can change state at the same time.

The SCXI-1161 is an 8-channel power relay module with eight independent one-form C relays. The relays are nonlatched, and the module powers up with its relays in the Normally Closed (NC) position or when the hardware reset is set on the module. You can set or reset each relay without affecting the other relays, or all the relays can change state at the same time.

The SCXI-1160 and SCXI-1161 modules only support multiplexed (also known as *serial*) mode. If you cable an MIO or AI device, or Lab or 1200 device, to one of these modules, you must set jumpers on the module to the MIO position. If you cable a DIO board to one of these modules, you must set jumpers on the module to the DIO position. If you have not cabled any device to the module, NI-DAQ will be using the SCXIbus backplane to communicate with the module, therefore the MIO/DIO jumpers are irrelevant.

If you are using remote SCXI, you can use the SCXI-1160 or SCXI-1161 with or without the SCXI-1200 DAQ module, because NI-DAQ will communicate with the SCXI-1160 or SCXI-1161 via the backplane and through the serial port cable.

SCXI-1162 and SCXI-1162HV

The SCXI-1162 and SCXI-1162HV are 32-channel optically isolated digital input modules. They accept 32 input signals from external equipment and condition the signals for input to a DAQ device while maintaining optical isolation from the host computer. The SCXI-1162 accepts 0 to +5 V digital signals; the SCXI-1162HV senses AC or DC signals up to 250 V.

You can call the `SCXI_Get_State` function to read the logical states of the digital input lines on the module.

The SCXI-1162 and SCXI-1162HV modules support both multiplexed (or *serial*) mode and parallel mode. You must set jumpers on the module correctly for multiplexed or parallel mode. If you cable an MIO or AI device, Lab-PC+, PCI-1200, or DAQCard-1200 to the SCXI-1162 or SCXI-1162HV, you must set jumpers on the module to the MIO position.

If you cable a DIO board to the module, you must set jumpers on the module to the DIO position. If you have not cabled any device to the module and NI-DAQ will be using the SCXIbus backplane to communicate with the module, the MIO/DIO jumpers are irrelevant.

If you are using remote SCXI, you can use the SCXI-1162 or SCXI-1162HV with or without the SCXI-1200 DAQ module, because NI-DAQ will communicate with the SCXI-1162 or SCXI-1162HV via the backplane and through the serial port cable.

SCXI-1163 and SCXI-1163R

The SCXI-1163 and SCXI-1163R are 32-channel optically isolated digital output modules. The SCXI-1163 makes available to external equipment up to 32 digital outputs from a DAQ device while maintaining optical isolation from the host computer and eliminating ground-loop problems. The SCXI-1163R is functionally equivalent to the SCXI-1163 but incorporates solid-state relays in place of the digital outputs. You can open or close each relay independently.

You can call the `SCXI_Set_State` function to control the digital output lines or relays of the module. You can call the `SCXI_Get_State` function to obtain the current states of the module. It is important to remember that `SCXI_Get_State` makes a hardware read only if the module is jumper-configured for and operating in parallel mode. When operated in serial mode, the driver retains the states of the digital output lines in memory. Consequently, a hardware write must take place before you can obtain the states on the module.

The module powers up with its digital output lines in a high state or its relays open. Calling `SCXI_Reset` also sets all the digital output lines to a high state.

The SCXI-1163 and SCXI-1163R modules support both multiplexed (or *serial*) mode and parallel mode. You must set jumpers on the module correctly for multiplexed or parallel mode. If you cable an MIO or AI device, or Lab or 1200 device to the SCXI-1163 or SCXI-1163R, you must set jumpers on the module to the MIO position. If you cable a DIO board to the module, you must set jumpers on the module to the DIO position. If you have not cabled any device to the module and NI-DAQ will be using the SCXIbus backplane to communicate with the module, the MIO/DIO jumpers are irrelevant.

If you are using remote SCXI, you can use the SCXI-1163 or SCXI-1163R with or without the SCXI-1200 DAQ module, because NI-DAQ will communicate with the SCXI-1163 or SCXI-1163R via the backplane and through the serial port cable.

SCXI-1200

The SCXI-1200 is a 12-bit data acquisition and control module. NI-DAQ communicates with the SCXI-1200 through either your PC parallel port or through a remote SCXI configuration connected to your PC serial port. The SCXI-1200 is functionally similar to the Lab-PC+ plug-in DAQ device. After you configure this module in the Measurement & Automation Explorer, you assign a logical device number to it. Using the device number, you can use the SCXI-1200 with almost any NI-DAQ function supported by the Lab-PC+ as if it were a plug-in device inside the PC; you can use the analog input functions, the analog output functions, the data acquisition functions, the waveform generation functions, the Digital I/O functions, and the Counter/Timer Functions, which are all described in Chapter 3, *Software Overview*, of the *NI-DAQ User Manual for PC Compatibles*. Appendix C, *NI-DAQ Function Support*, in the *NI-DAQ Function Reference Manual for PC Compatibles* shows exactly which NI-DAQ functions support the SCXI-1200.

If you configure the SCXI-1200 for multiplexed mode, it can access the analog bus on the SCXI backplane. When you configure other analog input modules in the chassis for multiplexed mode, the SCXI functions can multiplex their input channels and send them on the analog bus on the SCXI backplane. So, if you configure the SCXI-1200 for multiplexed mode, you can use it to read the multiplexed output from other SCXI analog input modules in the chassis. In addition, you can multiplex the analog input channels on the SCXI-1200 with the input channels from other analog input modules in the chassis during the same scanning operation. The SCXI-1200 switches its analog input channels in descending order (the other analog input modules switch their channels in ascending order). The *SCXI Application Hints* section in Chapter 3, *Software Overview*, of the *NI-DAQ User Manual for PC Compatibles* explains how to use the SCXI functions in analog input applications with the SCXI-1200 in multiplexed mode.

If you are not using other analog input modules in the chassis along with the SCXI-1200, you should configure the SCXI-1200 for stand-alone mode. In stand-alone mode you do not need the SCXI functions to perform analog input operations, you simply use the SCXI-1200 with the DAQ and Lab_ISCAN functions as if it were a plug-in device inside your PC. You can

still use digital or relay modules or analog output modules in the chassis with the SCXI-1200 configured for parallel mode; you need SCXI functions to operate those modules.

When you perform analog input data acquisitions with the SCXI-1200 connected to the parallel port of the PC, the module issues an interrupt through the parallel port, which the PC services to retrieve data. When the SCXI-1200 is connected to the PC through a remote SCXI configuration, NI-DAQ will query the remote SCXI unit for the presence of acquired data, and the remote SCXI unit will send data back serially to the PC.

MIO and AI DAQ Devices (except Parallel Ports)

The MIO and AI DAQ devices (except parallel ports) support the following analog input functionality when using the SCXI analog input modules:

- Single-channel analog input using the analog input functions described in Chapter 3, *Software Overview*, of the *NI-DAQ User Manual for PC Compatibles*.
- Single-channel data acquisition using the data acquisition functions described in Chapter 3, *Software Overview*, of the *NI-DAQ User Manual for PC Compatibles*.
- Multiple-channel and interval scanning using the *SCAN* functions described in Chapter 3, *Software Overview*, of the *NI-DAQ User Manual for PC Compatibles*.

You also can use the analog output modules and digital modules in multiplexed mode with the MIO and AI devices (except parallel ports). If you are using analog input modules with digital or analog output modules, you must cable the MIO or AI device to an analog input module.

It is important to remember that when a DAQ device is cabled to an SCXI module, some of the DAQ device I/O connector pins and therefore some of the device resources will be reserved for SCXI use.

The following MIO and AI device resources are reserved by SCXI:

- The E Series devices use digital I/O lines 0, 1, 2, and 4 for communication with SCXI. Other digital I/O lines are available for Digital I/O functions and can be configured for either input or output on an individual basis.
- The Am9513-based devices use digital I/O lines ADIO0 through ADIO2 to communicate with the SCXI hardware; NI-DAQ reserves those lines as output. NI-DAQ also reserves digital I/O

line BDIO0 as input for SCXI communication. All of port A is reserved by NI-DAQ, but lines BDIO1 through BDIO3 are available for general use as input as long as none of the configured SCXI modules need to communicate back to the DAQ device; otherwise, NI-DAQ will also reserve the lines in port B.

- When you use an SCXI-1140 module, the scan interval counter on the MIO or AI device controls the track/hold state of the module. When you set up the module for a single-channel operation, NI-DAQ reserves the scan interval counter. Refer to the `SCXI_Track_Hold_Setup` function for more information.
- The SCXI-1100 module drives the MIO or AI device analog input channel 0; if you use the SCXI terminal block with the temperature sensor in the DTEMP configuration, the SCXI-1100 also drives analog input channel 1 of the MIO or AI device (except parallel ports).
- The SCXI-1120 and SCXI-1120D modules drive analog input channels 0 through 7 on the MIO or AI device, *even if you are operating the module in multiplexed mode*. In addition, if the temperature sensor on the terminal block is in the DTEMP configuration, the SCXI-1120 and SCXI-1120D also drive analog input channel 15. Notice that you must operate the MIO or AI device in or NRSE mode to read the temperature sensor in the DTEMP configuration.
- The SCXI-1121 module drives analog input channels 0 through 3 on the MIO or AI device, *even if you are operating the module in multiplexed mode*. In addition, if the temperature sensor on the terminal block is in the DTEMP configuration, the SCXI-1121 also drives analog input channel 4.
- The SCXI-1122 module drives analog input 0; if you use the SCXI terminal block with the temperature sensor in the DTEMP configuration, the SCXI-1122 also drives analog input channel 1 of the MIO or AI device.
- The SCXI-1140 module drives analog input channels 0 through 7 on the MIO or AI device, *even if you are operating the module in multiplexed mode*.
- The SCXI-1141 module drives analog input channels 0 through 7 on the MIO or AI device, *even if you are operating the module in multiplexed mode*.

Lab and 1200 Devices (except Parallel Ports)

These DAQ devices support the following analog input functionality when using the SCXI analog input modules:

- Single-channel analog input using the analog input functions described in Chapter 3, *Software Overview*, of the *NI-DAQ User Manual for PC Compatibles*.
- Single-channel data acquisition using the data acquisition functions described in Chapter 3, *Software Overview*, of the *NI-DAQ User Manual for PC Compatibles*.
- The Lab and 1200 devices support continuous and interval scanning on all analog input modules in both multiplexed and parallel mode.

It is important to remember that when a DAQ device is cabled to an SCXI module, some of the device resources will be reserved for SCXI use. The following resources are reserved by SCXI:

- Lab and 1200 devices digital I/O lines PB4 to PB7 are used as output communication lines to SCXI. If the SCXI-1200 is the only module in the chassis, these communication lines are not needed, and they are not reserved by NI-DAQ.
- Lab and 1200 devices digital I/O line PC1 is used as an input communication line to SCXI. The remaining lines of these ports are available for input only. If the SCXI-1200 is the only module in the chassis, these communication lines are not needed, and they are not reserved by NI-DAQ.
- When you use an SCXI-1140 module, counter B1 of the Lab or 1200 devices controls the track/hold state of the module. When the module is not set up for an input operation, these counters are available for general use; otherwise, they are reserved. Refer to the `SCXI_Track_Hold_Setup` function description in Chapter 2, *Function Reference*, of the *NI-DAQ Function Reference Manual for PC Compatibles* for more information.
- The SCXI-1100 module drives analog input channel 0 of the DAQ device; if you use the SCXI-1300 terminal block with the temperature sensor in the DTEMP configuration, the SCXI-1100 also drives analog input channel 1. The SCXI-1200 cannot read the temperature sensor in DTEMP mode because it reads all analog voltages off the analog lines of the SCXIbus backplane.
- The SCXI-1120 and SCXI-1120D modules drive analog input channels 0 to 7, *even if you are operating the module in multiplexed mode*. In addition, if the temperature sensor on the terminal block

is in the DTEMP configuration, the SCXI-1120 also drives analog input channel 15. Notice that a Lab or 1200 device cannot read the temperature sensor on the SCXI-1320 terminal block if the SCXI-1320 is in the DTEMP configuration.

- The SCXI-1121 module drives analog input channels 0 to 3, *even if you are operating the module in multiplexed mode*. In addition, if the temperature sensor on the terminal block is in the DTEMP configuration, the SCXI-1121 also drives analog input channel 4. The SCXI-1200 cannot read the temperature sensor in DTEMP mode because it reads all analog voltages off the analog lines of the SCXIbus backplane.
- The SCXI-1122 module drives analog input channel 0 of the DAQ device; if you use the SCXI-1300 terminal block with the temperature sensor in the DTEMP configuration, the SCXI-1122 also drives analog input channel 1. The SCXI-1200 cannot read the temperature sensor in DTEMP mode because it reads all analog voltages off the analog lines of the SCXIbus backplane.
- The SCXI-1140 module drives analog input channels 0 to 7, *even if you are operating the module in multiplexed mode*.
- The SCXI-1141 module drives analog input channels 0 to 7, *even if you are operating the module in multiplexed mode*.

DIO-24 and the DIO-96

The DIO-24 and DIO-96 digital I/O devices work with the digital modules and analog output modules. It is important to remember that when a digital I/O device is cabled to an SCXI module, some of the device I/O pins, and therefore some of the device resources, are reserved for SCXI use. SCXI reserves the following DIO-24 and DIO-96 resources when cabled to a digital or analog output module in multiplexed mode:

- DIO-24 digital I/O lines PB0 to PB3 and the DIO-96 digital output lines APB0 to APB3 are the output communication lines to SCXI. The entire port is reserved by NI-DAQ.
- DIO-24 digital I/O line PA0 and DIO-96 digital I/O line APA0 are the input communication lines from SCXI. The remaining lines of these ports are available only for input.

When you cable a DIO-24 to an SCXI-1162, SCXI-1162HV, SCXI-1163, or SCXI-1163R in parallel mode, the 24 digital lines on the DIO-24 are directly connected to channels 0 through 23 on the module; you cannot access channels 24 to 31 on the module in parallel mode with a DIO-24.

When you cable a DIO-96 to an SCXI-1162, SCXI-1162HV, SCXI-1163, or SCXI-1163R in parallel mode, the lines in DIO-96 ports 0 to 3 are directly connected to the channels on the module. If you configure the module for parallel (secondary) mode and cable the second half of the ribbon cable to the module, DIO-96 ports 6 to 9 are directly connected to the digital channels on the module.

You can use the `DIG_In_Port` and `DIG_Out_Port` functions to access the SCXI-1162, SCXI-1162HV, SCXI-1163, and SCXI-1163R digital channels in parallel mode by using the correct onboard port numbers, listed above.

You cannot cable a DIO-24 or DIO-96 to an analog input module.

DIO-32F and DAQDIO 6533 Device (DIO-32HS)

The DIO-32F and the DAQDIO 6533 device (DIO-32HS) digital I/O boards support the digital modules and analog output modules. It is important to remember that when a digital I/O board is cabled to an SCXI module, some of the digital board I/O pins, and therefore some of the board resources, are reserved for SCXI use. SCXI reserves the following DIO-32F and DAQDIO 6533 device (DIO-32HS) resources when cabled to a digital or analog output module in multiplexed mode:

- DIO-32F digital I/O lines DIOB0 to DIOB3 are the output communication lines to the SCXI module. The entire port is reserved by NI-DAQ.
- DIO-32F digital I/O line DIOA0 is the input communication line from the SCXI module. The remaining lines of this port are available only for input.
- DAQDIO 6533 (DIO-32HS) digital I/O lines DIOB0 to DIOB3 are output communication lines to the SCXI module. The remaining lines of this port are available for either input or output.
- DAQDIO 6533 (DIO-32HS) digital I/O line DIOA0 is the input communication line from the SCXI module. The remaining lines of this port are available for either input or output.

Use an SCXI-1348 cable assembly to cable a DIO-32F or an SCXI-1355 cable assembly to cable a DAQDIO 6533 device (DIO-32HS) to an SCXI-1162, SCXI-1162HV, SCXI-1163, or SCXI-1163R in parallel mode. The 32 digital lines on the DIO-32F or DAQDIO 6533 device (DIO-32HS) are directly connected to the 32 channels on the module. You can use the

DIG_In_Port and DIG_Out_Port functions to access the SCXI-1162, SCXI-1162HV, SCXI-1163, or SCXI-1163R channels in parallel mode by using the correct onboard port numbers.

You cannot cable a DIO-32F or DAQDIO 6533 device (DIO-32HS) to an analog input module.

VXI-DAQ Devices

Chapter 15

This chapter contains overview information on VXI-DAQ devices, including the VXI-DIO-128, VXI-AO-48XDC, VXI-SC-1102, VXI-SC-1102B, VXI-SC-1102C, VXI-SC-1150, VXI-MIO-64E-1, and VXI-MIO-64XE-10.

National Instruments VXI-DAQ devices are in many respects similar to their plug-in counterparts, but they have higher performance and more features. They provide a high-end solution for applications that demand larger channel counts and greater throughput.

See Chapter 1, *MIO and AI Devices*, for more information on the VXI-MIO devices.

RTSI

On a VXI chassis the RTSI bus is implemented with VXI trigger bus lines. Each trigger bus line connects to all the VXI slots. The following table shows the mapping between the RTSI bus line (identifier) and the corresponding VXIbus trigger line.

Table 15-1. RTSI Bus Line and VXIbus Trigger Mapping

RTSI bus line identifier	VXIbus trigger line
ND_RTSI_0	VXIbus TTL Trigger 0 (TTLTRG0)
ND_RTSI_1	VXIbus TTL Trigger 1 (TTLTRG1)
ND_RTSI_2	VXIbus TTL Trigger 2 (TTLTRG2)
ND_RTSI_3	VXIbus TTL Trigger 3 (TTLTRG3)
ND_RTSI_4	VXIbus TTL Trigger 4 (TTLTRG4)
ND_RTSI_5	VXIbus ECL Trigger 0 (ECLTRG0)
ND_RTSI_6	VXIbus ECL Trigger 1 (ECLTRG1)
ND_RTSI_CLOCK	VXIbus ECL Trigger 0 (ECLTRG0)

**Note**

Unpredictable behavior might result if other VXIbus devices simultaneously use the same VXIbus trigger line the VXI-MIO devices are using to synchronize their operations.

VXI-DIO-128 Digital I/O Board

The VXI-DIO-128 is a 128-channel parallel digital I/O module for the VXIbus. The module uses eight 16-bit programmable peripheral interfaces (PPIs) that can be subdivided further into 16 8-bit ports. Four 82C55 PPI chips control 64 open-drain output channels. Four 82C55 PPI chips control 64 input channels with programmable thresholds. These 16 ports are referred to as ports 0 through 15 by the Digital I/O functions.

Ports 0 through 7 can be configured only as input ports. The threshold voltage for each of these input ports you can program independently by selecting a voltage between -32 and $+31.75$ V in 250 mV steps. By comparing the input digital signal to the threshold values, the module can translate the input voltage levels above the threshold to active high readings and below the threshold to active low readings.

Ports 8 through 15 can be configured only as output ports. However, each of these ports is equipped with *read-back capability*. Each output line has built-in transient suppression diodes, which protect against the voltage spikes that are generated when relays turn off and on. Writing 1 to a given line turns the relay driver on, which grounds the output pin. Thus, when you use a line as a general-purpose output, an inversion occurs.

VXI-AO-48XDC Analog Output Board

The VXI-AO-48XDC is a precise DC setpoint module for the VXIbus. This module contains 48 voltage outputs plus 48 separate current outputs for a total of 96 analog output channels with 18-bit DAC resolution. Each one of these channels is independently programmable. The channel numbering is 0 through 47, with each channel controlling a pair of voltage and current outputs. Whether a channel controls its voltage or current output is determined by a call to `AO_Change_Parameter`.

The VXI-AO-48XDC has one 18-bit DAC that is time-division multiplexed to create the 48 voltage output channels and the 48 current output channels. The channel data is stored in nonvolatile RAM. This feature enables the module to support the following two update modes: update when written to and later internal update mode. Furthermore, this design allows power on

values for all the analog output channels. All analog channels are guaranteed to be at their power-on values 5 ms after de-assertion of system reset.

VXI-AO-48XDC Digital I/O

The VXI-AO-48XDC contains 32 lines of digital I/O. These lines are divided into four ports of 8 lines each. These four ports are referred to as ports 0 through 3 by the digital I/O functions. You can program each of these ports on a line basis; you can configure each line individually for input or output. In addition, each line that you configure as an output line has read-back capability (that is, by reading the port associated with a particular line, you can determine what digital value the output line is currently asserting). These digital I/O ports operate only in nonlatched mode.

VXI-DAQ Signal Conditioning

VXI-DAQ signal conditioning behaves like traditional (external) SCXI, but with some important differences:

- The VXI-MIO controls the VXI-SC-1000 and the VXI-SC submodules using the VXI local bus. Up to two signal conditioning submodules plug into a single carrier module.
- A VXI-SC-1000 consists of all of the physically contiguous modules (and associated carrier modules) that are inserted to the right of a given VXI-MIO board, which is the cabled device.
- Conditioned data is multiplexed onto a special VXI AI channel (ND_VXI_SC), rather than the user-addressable AI channels for the MIO board.
- External SCXI still can be cabled to a VXI-MIO board and, in fact, can be used simultaneously with VXI-DAQ signal conditioning.
- Each VXI-DAQ module, as well as the carrier module, has a unique VXI-DAQ logical address.
- Modules are numbered as follows: for a VXIbus chassis in the upright position, the modules are numbered sequentially, first from top to bottom (slot 1 to the left), then from left to right.

Although it is important to understand these differences, the NI-DAQ programming model is the same, with one exception: if you are using the C API, you must use the special AI channel (ND_VXI_SC) to read your conditioned data. In LabVIEW, however, the onboard channel string is

ignored when communicating with a VXI-SC-1000. In either case, you specify the chassis ID and module number of the VXI-SC-1000 and VXI-SC submodule, exactly as if you were communicating with a traditional SCXI chassis.

VXI-SC-1102 Submodule

The hardware features of this module are identical to those of the SCXI-1102. See *The SCXI-1102* section of Chapter 14, *SCXI Hardware*, for more details.

VXI-SC-1102B and the VXI-SC-1102C Submodules

The VXI-SC-1102B and the VXI-SC-1102C are variants of the VXI-SC-1102. They are functionally identical to the VXI-SC-1102 submodule except for their higher bandwidth support: 200 Hz for the VXI-SC-1102B and 10 KHz for the VXI-SC-1102C, in comparison with to the 2 Hz bandwidth limitation of the VXI-SC-1102.

VXI-SC-1150 Submodule

The VXI-SC-1150 submodule plugs directly into the VXI-SC-1000 carrier module and holds up to four signal conditioning minipods (SCMPs). The VXI-SC-1150 is designed to work in conjunction with other VXI-SC submodules, such as the VXI-SC-1102, to support transducer conditioning. When the VXI-SC-1150 is populated with the current excitation minipods and voltage excitation minipods, you can use these sources to excite transducers, including RTDs, strain gauges, thermistors, and resistances.

The VXI-SC-1150 is divided into four SCMP sockets. Each socket has two connectors. The 24-pin connector provides excitation to the front panel 96-pin DIN connector. The other 28 pin connector supplies power and a communication channel to the SCMP from the VXI-SC-1000 carrier module.

Each SCMP has an individual ID that the VXI-SC-1150 recognizes and passes along to the NI-DAQ configuration utility, Measurement & Automation Explorer, which reports the ID to you. Therefore, you can use auto-configuration to control and recognize your setup. In addition, the VXI-SC-1150 has its own module ID (44 decimal) and its own VXI device ID (812 decimal).

PXI DAQ Devices

Chapter 16

This chapter contains overview information on PXI DAQ hardware.

RTSI

On a PXI chassis the RTSI bus is implemented with PXI trigger bus lines. Each trigger bus line connects to all the PXI slots. The following table shows the mapping between the RTSI bus line (identifier) and the corresponding PXI trigger bus line.

Table 16-1. RTSI Bus Line and PXI Bus Trigger Mapping

RTSI bus line identifier	PXI trigger bus line
ND_RTSI_0	PXI Trigger 0
ND_RTSI_1	PXI Trigger 1
ND_RTSI_2	PXI Trigger 2
ND_RTSI_3	PXI Trigger 3
ND_RTSI_4	PXI Trigger 4
ND_RTSI_5	PXI Trigger 5
ND_RTSI_6	PXI Star
ND_RTSI_CLOCK	PXI Trigger 7



Note

Unpredictable behavior might result if other PXI devices simultaneously use the same PXI trigger bus line the PXI DAQ devices are using to synchronize their operations.

PXI DAQ Signal Conditioning

The PXI-1010 chassis has four slots for SCXI modules. You can use these four SCXI slots the same way you would use a traditional (external) SCXI chassis by cabling a DAQ device to one of the SCXI modules. See Chapter 14, *SCXI Hardware*, for more information. In addition, there is an internal connection between PXI slot 8 and the SCXI bus. A device in slot 8 can be used to program the SCXI modules, sample analog signals from the modules, and provide clock signals for scanning the channels on the modules. If you use this internal connection, you do not need to connect a cable from your device to an SCXI module. However, any modules that you want to use in parallel mode must still be cabled to a device.

A PXI E Series device in slot 8 can sample SCXI analog input channels via a special channel connected to the SCXI bus (ND_PXI_SC). See Appendix B, *Analog Input Channel, Gain Settings, and Voltage Calculation*, of the *NI-DAQ Function Reference Manual for PC Compatibles* for more information. If you use the internal connection to the SCXI bus instead of cabling to an SCXI module, all the regular analog input channels on your device are available for other uses.

Some resources of the device are reserved whether you use the internal connection to the SCXI bus or cable the device to a module. Some of the digital I/O lines (and the scan interval counter in the case of the SCXI-1140) are reserved for SCXI.

A PXI E Series device in slot eight can use the SCXI slots in the PXI-1010 and one or more external SCXI chassis at the same time. You need an SCXI-1346 multichassis adapter for each external chassis after the first. The modules cabled to the device must all be in multiplexed mode. The first external chassis uses analog input channel zero, the second uses analog input channel one, and so on. You must set a unique chassis address for each chassis, including the internal chassis.

NI 5411 Devices

This chapter contains overview information on the NI 5411 arbitrary waveform generator devices for ISA and PCI.

NI 5411 Arbitrary Waveform and Pattern Generator Devices

The NI 5411 devices are high speed arbitrary waveform and pattern generator devices. The NI 5411 are available for both ISA and PCI buses. They are identical in all other respects.

NI 5411 Device Characteristics

Table 17-1 summarizes the key analog and digital output characteristics for the NI 5411 devices. Refer to your *NI 5411 User Manual* for a description of all the features of your device.

Table 17-1. NI 5411 Device Characteristics

Characteristics	NI 5411 for ISA and PCI
Number of Channels	One
Maximum Update Rate	40 MHz
DAC Resolution	12-bit
DDS Accumulator Size (only for DDS Mode)	32-bit
Digital Patterns	16 bits with clock signal
Output Range	± 5 V into 50 Ω load ± 10 V into unterminated load
Output Attenuation (after the DAC)	0 through 73.000 dB in 0.001 dB steps

Table 17-1. NI 5411 Device Characteristics (Continued)

Characteristics	NI 5411 for ISA and PCI
Waveform Memory Depth <ul style="list-style-type: none"> — ARB Mode — Direct Digital Synthesis (DDS) Mode 	2,000,000, 16-bit samples (standard) 16,384, 16-bit samples
Waveform Segment Size <ul style="list-style-type: none"> — ARB Mode 	256 samples minimum Memory depth maximum Note Segment size should be a multiple of 8 samples.
Waveform Segment Loops	65,535 maximum
Waveform Links	290 different segments
Marker Output	TTL level, one available for every segment
SYNC Output	TTL level with variable duty cycle
External Trigger	TTL level
RTSI Trigger Bus	Available
Phase Locking	1 MHz or 10 MHz reference clock, software selectable
Output Impedance	50 Ω or 75 Ω (video), software selectable
Low-Pass Filter	16 MHz, software-switchable to ON or OFF
Digital Half-Band Interpolating Filter	80 MSPS, software-switchable to ON or OFF
Operation Modes	Single, Continuous, Stepped, and Burst
Fully Software-Configurable	Plug and Play

NI 5411 Device Waveform Generation

The NI 5411 for ISA and PCI can generate arbitrary waveforms at the output at the sustained update rate of 40 MHz. The waveforms are first loaded as segments into the waveform memory on the board. They then can be generated as a sequence of any combination of segments. Because you can loop over the segments and link to any other looped segments, the effective waveform memory becomes even larger.

Figure 17-1 shows the concept of waveform sampling, waveform segmentation, and waveform sequencing.

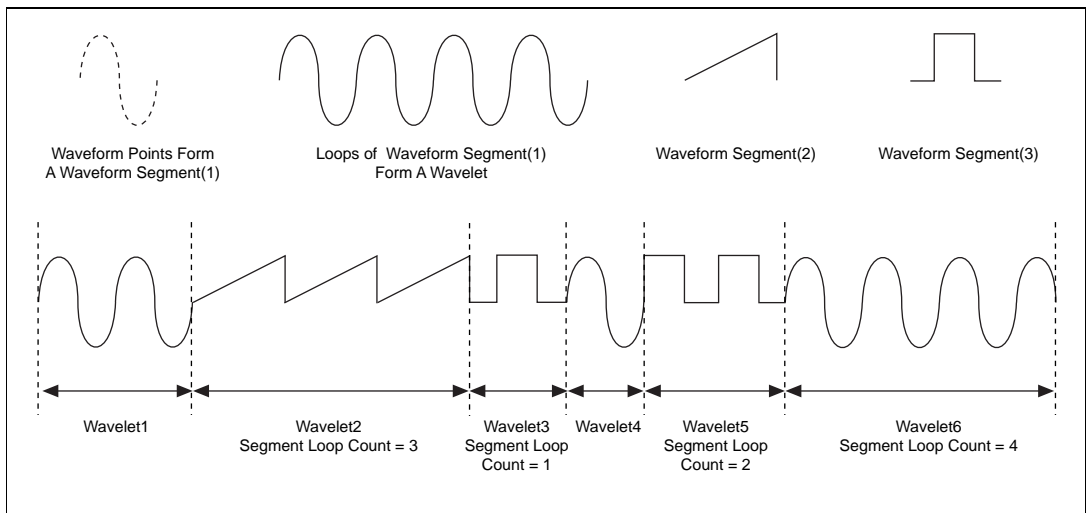

Figure 17-1. Examples of Waveform Generation

Because deep memory is available on the NI 5411 for ISA and PCI, you do not need to tie up the bus by transferring the waveforms as they are being generated. Various operational modes, such as continuous, stepped, and burst, are available on these devices to further enhance the capabilities of your arbitrary waveform generation.

DDS Mode

The NI 5411 devices have a 32-bit accumulator, which is used with a 16,384-sample lookup memory to create a Direct Digital Synthesizer (DDS). The lookup memory is dedicated to the DDS mode only and cannot be used in ARB mode. You can store one cycle of a repetitive waveform; for example, a sine wave, a triangular wave, a square wave, or an arbitrary

wave in the lookup memory. Then, you can change the frequency of that waveform by just sending one instruction. The frequency switching is phase continuous. This mode is extremely useful for very fine resolution function generation. You can generate sine tones up to 16 MHz with a resolution of 10 MHz. Because this mode uses an accumulator, waveform generation loops back to the beginning of the lookup memory after passing through the end of the lookup memory.

The SYNC output is a transistor-transistor-logic (TTL) version of the sine waveform being generated at the output. You can think of the SYNC output as a very high resolution, software-programmable clock source for many applications. You also can vary the duty cycle of SYNC output on the fly by using software control. The SYNC output might not carry any meaning for any other types of waveforms being generated.

No linking or looping capabilities are available in this mode; however, very simple triggering is available. DDS mode should be used for standard function generation rather than for arbitrary waveform generation.

NI 5411 Device Waveform Pattern Generation

The NI 5411 devices can generate 16-bit digital TTL patterns that correspond to the analog waveform being generated. It provides a clock signal with this 16-bit digital output so that you can test your digital device by latching these digital patterns. The digital pattern generation also can use the full linking and looping features, triggering and timing features of the NI 5411 for ISA and PCI. The pattern generation feature is useful for testing digital devices like parallel DACs and serial DACs. It is useful in testing semiconductor devices.

NI 5411 Device Pattern Generation Timing

The NI 5411 devices can generate waveforms based on an internal 40 MHz update clock. Further division of the clock up to 65,535 segment loops is possible by using an internal interval counter that is 16-bit wide. Set the interval settings before starting the waveform generation.

You also can phase-lock the internal timebase to an external reference frequency of 1 or 10 MHz. This feature is very useful for multi-board synchronization. You can do the phase-locking by using an external I/O connector or by way of a RTSI clock line on a RTSI bus.

NI 5411 Device Waveform Generation Triggering

The NI 5411 devices have four different operational modes that you can set up before starting the waveform generation.

Table 17-2. NI 5411 Operational Modes

Mode	Description
Single	The waveform described by the user in the sequence list is generated once by going through all the sequence list. Only the start trigger is required.
Continuous	The waveform described by the user in the sequence list is generated infinitely by recycling through all the sequence list. Only the start trigger is required.
Stepped	After the start trigger is received, the waveform described by the first sequence entry is generated. Then, the device waits for the next trigger signal. At triggering, the waveform described by the second sequence entry is generated, and so on. When all of the sequence list is exhausted, the cycle returns to first sequence entry.
Burst	After the start trigger is received, the waveform described by the first sequence entry is generated until another trigger is received. At triggering, the previous waveform is completed before the waveform described by the second sequence entry is generated, and so on. When all of the sequence list is exhausted, the cycle returns to the first sequence entry.



Note

Refer to the `AO_Change_Parameter`, `WFM_Group_Control`, ***and*** `WFM_Load` ***function descriptions in Chapter 2, Function Reference, of the NI-DAQ Function Reference Manual for PC Compatibles for more information on NI 5411 operational modes.***

NI 5411 Device Feature Settings

You can change the following feature settings even when the waveform generation is in process:

- Duty cycle of the SYNC output.
- Output (relay) to ON or OFF.
- Output Impedance to 50 or 75 Ω .
- Switching the analog filter ON or OFF.
- Switching the digital filter ON or OFF.

**Note**

Refer to the `AO_Change_Parameter` function description in Chapter 2, Function Reference, the NI-DAQ Function Reference Manual for PC Compatibles for more information on setting these features.

You can change the method used to transfer data using `Set_DAQ_Device_Info`. Possible values are:

- DMA—data transfers done via DMA (PCI-5411 only).
- Foreground—data transfers done via the CPU.
- Automatic—selects most appropriate transfer method.

Transfers done via DMA require memory to be page locked. If a computer is having a hard time locking the memory it needs to do a data transfer, switch the data transfer method to Foreground.

**Note**

Refer to the `Set_DAQ_Device_Info` function description in Chapter 2, Function Reference, of the NI-DAQ Function Reference Manual for PC Compatibles for more information on setting this feature.

NI 435X Devices

A graphic showing the word "Chapter" in a serif font above the large number "18", all enclosed in a double-line rectangular border.

This chapter contains overview information on the NI 435X devices, including the NI 4350 for ISA, USB, and PCMCIA, and the NI 4351 for PCI and PXI.

For more detailed descriptions of the hardware functionality and specifications, see the *NI 4350 User Manual*. Also, the 435X instrument driver software documentation contains detailed information on how to write programs to control the 435X device for making measurements.

NI 435X devices are designed especially for data logging applications and feature accurate DC voltage. This family of devices can also provide thermocouple measurements as well as resistance temperature detector, thermistor, and ohm measurements using the built-in precision current source. The ultra-low leakage construction, in addition to analog and digital filtering, gives the 435X devices excellent resolution, accuracy, and noise rejection.

You can reference your floating voltage signal by using software-programmable ground-referencing, without compromising the measurement, even if the signal is ground-referenced. Software-programmable open-thermocouple detection enables you to quickly detect a thermocouple, which might have broken before or during measurement. The current source supplies 25 μA for measuring a maximum resistance of 600 $\text{k}\Omega$. NI 4351 also has a 1 mA current source for providing excitation to resistive sensors such as RTDs. In addition, the 435X devices have TTL-compatible digital I/O for monitoring TTL level inputs, alarms, and external device interfacing.

NI 435X Device Analog Input

The NI 4350 for PCMCIA has eight differential analog channels numbered 0 through 7, and the NI 435X for ISA, USB, PCI, and PXI has 16 differential channels numbered 0 through 15. The analog input channels are multiplexed into a 24-bit sigma-delta ADC. All analog channels have a low-pass filter to reject high frequency noise. Every channel has two settings: ground-referencing and open-thermocouple detection. If you

switch on the ground-referencing, CH– is referenced to analog ground through a 10 M Ω internal impedance. If you switch on open-thermocouple detection, CH+ is connected to +2.5 V through a weak pull-up of 10 M Ω internal impedance. You can set ground-referencing and open-thermocouple detection on a per channel basis. Table 18-1 summarizes the analog input ranges for the 435X devices.

Table 18-1. Analog Input Ranges for the 435X Devices

Range	Analog Input						
	Volts	± 0.625	± 1.25	± 2.5	± 3.75	+7.5	± 15
4-Wire Ohms	25 k	50 k	100 k	150 k	300 k	600 k	

NI 435X Data Acquisition

The NI 435X devices can perform single-channel data acquisition and multiple-channel data acquisition. You select a single analog input channel and input range setting for single-channel data acquisition. The device performs a single A/D conversion on that channel for every sample interval.

For multiple-channel scanned data acquisition, the NI 435X scans a set of analog input channels, all with the same input range. In this method, a scan sequence indicates which analog channels to scan. The length of this scan sequence can be one to eight for the NI 4350 for PCMCIA and one to 16 for the NI 435X for ISA, USB, PCI, and PXI. Table 18-2 summarizes the ranges for the 435X device data acquisition.

Table 18-2. Ranges for 435X Device Data Acquisition

Notch Frequency	Number of Channels	Reading Rate	Harmonics of Noise Frequencies Filtered (Hz)
10 Hz	1	10 Hz	10
50 Hz	1	50 Hz	50
60 Hz	1	60 Hz	60
10 Hz	$N > 1$	2.8 Hz	10

Table 18-2. Ranges for 435X Device Data Acquisition (Continued)

Notch Frequency	Number of Channels	Reading Rate	Harmonics of Noise Frequencies Filtered (Hz)
50 Hz	$N > 1$	8.8 Hz	50
60 Hz	$N > 1$	9.7 Hz	60

You can scan any combination of channels in any order. You can also scan the same channel multiple times in the scan sequence. An example sequence follows: channel 7, channel 3, channel 0, channel 3, channel 7, channel 5, channel 6, channel 4.

You can use the 435X devices to perform buffered scans. When the device is configured, you can use it to acquire data one scan at a time or repeatedly using a timed buffered acquisition.

The NI 435X performs an A/D conversion once every sample interval. When the end of the scan sequence is reached, the device continues acquiring data starting from the first entry in the sequence.

NI 435X Acquisition Timing

The onboard counter can perform timing for data acquisition, or you can perform timing externally in software. The onboard counter controls the sample rate, which also affects the filtering as shown in Table 18-3.

Table 18-3. Relationship between Filtering and Available Sample Rates

Harmonics of Noise Frequencies Filtered (Hz)	Single Channel Measurement Mode (reading/s)	Multiple Channel Measurement Mode (reading/s)
10, 50, and 60	10	2.8
50	50	8.8
60	60	9.7

NI 435X Current Source

The NI 435X device has a built-in 25 μA current source (exact value stored on board). You can use it to provide excitation to RTDs, thermistors, and other resistors. Use the ohms mode to make measurements using the current source. NI 4351 devices also have an additional 1 mA current source for more accurate measurements with RTDs.

NI 435X Digital I/O

The NI 4350 for PCMCIA has one 4-bit digital port. The NI 435X for ISA, USB, PCI, and PXI has one 8-bit digital port. These ports are referred to as port 0 by the digital I/O functions.

You can configure the entire digital port as either input or output, or you can configure individual lines for either input or output. The port has read-back capability (that is, by reading the port, you can determine what digital value the output port is currently asserting). This port operates in a nonlatched mode only.

NI 40XX Devices

A graphic consisting of a black-bordered square. Inside the square, the word "Chapter" is written in a serif font at the top. Below it, the number "19" is written in a large, bold, serif font. The entire graphic is centered within a larger white rectangular area.

This chapter contains overview information on the NI 40XX devices, including the NI 4050 and NI 4060 instruments.

For detailed descriptions of the hardware functionality and specifications on the 4050 and 4060 instruments, see the user manual that shipped with your device. Also, the 40XX instrument driver software documentation contains detailed information on how to write programs to control the 4050 and 4060 devices for making measurements.

NI 40XX Device Input

The NI 40XX devices have one input channel. NI 4050 instruments have four measurement modes: 2-wire ohms, DC volts, true RMS AC, and diode. NI 4060 instruments have additional modes: DC current, RMS AC current, and 4-wire ohms. Both the 4050 and 4060 devices have five input ranges for measuring DC voltages: ± 250 V, ± 25 V, ± 2 V, ± 200 mV, and ± 20 mV. The devices isolate signals up to 250 V.

The 4050 and 4060 devices have five input ranges for measuring AC voltages: $250 V_{\text{RMS}}$, $25 V_{\text{RMS}}$, $2 V_{\text{RMS}}$, $200 \text{ mV}_{\text{RMS}}$, and $20 \text{ mV}_{\text{RMS}}$.

The 4050 and 4060 devices have five input ranges for measuring resistance: $2 \text{ M}\Omega$, $200 \text{ k}\Omega$, $20 \text{ k}\Omega$, $2 \text{ k}\Omega$, and 200Ω . The devices measure resistance by sending a current through the resistor under test and measuring the voltage this current produces across the resistor. The devices also have an extended ohms range. In this range, the device adds a $1 \text{ M}\Omega$ resistor in parallel with the resistor under test, then calculates the value of the resistor being tested. NI 4060 devices have 4-wire in addition to 2-wire ohms mode. In these modes, the current used to excite the resistance under test is routed externally to the device.

NI 4060 instruments have two input ranges for measuring current: 200 mA and 20 mA. In current mode, the device measures current by routing the signal through an internal shunt resistor; the current excites the shunt resistor to produce a voltage. The device also has two ranges for measuring true RMS AC current—200 mA RMS and 20 mA RMS.

Diode drops of up to 2 V can be measured in the diode mode on both 4050 and 4060 devices. On the NI 4050 device, you can also measure AC and DC current by using the optional current shunt accessories.

NI 40XX Data Acquisition

The NI 4050 device can perform single-channel data acquisition. Before you make an acquisition, you must select the mode, range, and notch filter frequency. On the 4060, you may also select whether to perform offset compensation with the measurement and how many conversions to average per measurement.

NI 40XX Data Acquisition Filtering and Timing

NI 40XX devices have three notch filter frequencies: 10 Hz, 50 Hz, and 60 Hz. The device filters out noise at harmonics of its notch frequency. Table 19-1 shows available notch filter frequencies and common power line frequencies filtered at these frequencies.

Table 19-1. Relationship between Notch Filter Frequency and Power Line Frequencies Filtered

Notch Filter Frequency (Hz)	Common Power Line Frequencies Filtered (Hz)
10	10, 50, 60, 400
50	50, 400
60	60

The reading rate on the 4050 and 4060 devices varies with notch filter frequency settings, as shown in Table 19-2.

Table 19-2. Relationship between Notch Filter Frequency and Single-Channel Acquisition Rate

Notch Filter Frequency (Hz)	Single-Channel Acquisition Rate (S/s)
10	10
50	50
60	60

On the NI 4060, the reading rate is dependent on whether offset compensation (autozero) is used, as shown in Table 19-3.

Table 19-3. Relationship between Notch Filter Frequency and Single-Channel Acquisition Rate when AutoZero Is Enabled

Notch Filter Frequency (Hz)	Single-Channel Acquisition Rate When Autozero is Engaged (S/s)
10 Hz	1.4
50 Hz	4.4
60 Hz	4.9

The NI 4060 acquisition rate also varies based on the number of conversions averaged per measurement. See the hardware user manual for details.

DSA Devices

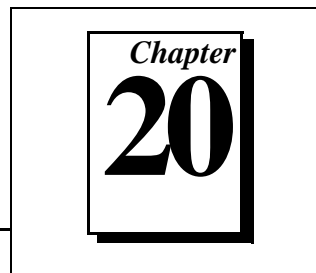

This chapter contains overview information on the DSA PCI-4451, PCI-4452, PCI-4551, and PCI-4552 devices.

PCI-445X and PCI-455X Devices

The PCI-445X and PCI-455X devices feature simultaneously sampled input channels using oversampling delta-sigma modulating ADCs. The PCI-4451 and PCI-4551 also feature simultaneously generated output channels using delta-sigma DACs. The hardware features on these devices are summarized in Table 20-1.

Table 20-1. PCI-445X and PCI-455X Hardware Features

Characteristic	PCI-445X	PCI-455X
Number of analog inputs	2 (4451), 4 (4452)	2 (4551), 4 (4552)
Number of analog outputs	2 (4451), 0 (4452)	2 (4551), 0 (4552)
Counter/Timer Chip	DAQ-STC	DAQ-TIO
Number of counters	2	2
Digital I/O	1 port with 8 lines	4 ports with 8 lines each

PCI-445X and PCI-455X Analog Input Channels

The PCI-445X and PCI-455X devices contain simultaneously sampled differential analog input channels based on delta-sigma ADCs. These converters use an oversampling and filtering technique to antialias the input signal. The converters produce 16-bit resolution readings. Each channel also has software configurable gain and coupling settings. The gains range from -20 to 60 dB in steps of 10 dB.

The signal range of each input channel is ± 10 V when set to DC coupling and 0 dB gain. When the input channels are set to AC coupling and 0 dB gain, the signal range is ± 10 VAC with a maximum input voltage of 42 VDC.

Data Acquisition

For data acquisition operations, the devices scan the channels in ascending order, but you can individually include or exclude a channel in a scan. For example, you can configure a data acquisition operation that scans channels 1 and 3 or channels 0, 1, and 2.

DSA devices format samples in a left-justified format in 32-bit data words. This means that the most significant bits of the data word contain the bits generated by the converter. When allocating data buffers, be sure to account for the 32-bit data width. Even though a number of DAQ and SCAN functions are declared to accept pointers to 16-bit data buffers, you should pass the pointers to 32-bit data buffers for the DSA devices.

You can configure a data acquisition operations to use any of the following additional modes:

- Posttrigger mode
- Pretrigger mode
- Double-buffered mode

Posttrigger mode collects a specified number of samples after the device receives a trigger. Refer to the *start trigger* discussion in the data acquisition timing section later in this chapter for details. After the user-specified buffer is full, the data acquisition stops.

Pretrigger mode collects data both before and after the device receives a trigger in posttrigger mode, either through software or by applying a hardware signal. The device collects samples and fills the user-specified buffer without stopping until the device receives the *stop trigger* signal. Refer to the *stop trigger* discussion in the data acquisition timing section later in this chapter for details. The device then collects a specified number of samples and stops the acquisition. The buffer is treated as a circular buffer—when the entire buffer has been written to, data is stored at the beginning again, overwriting the old data. When data acquisition stops, the buffer has samples from before and after the stop trigger occurred. The number of samples saved depends on the length of the user-specified buffer and on the number of samples specified to be acquired after receipt of the trigger.

Double-buffered mode, like pretrigger mode, also fills the user-specified buffer continuously. You can call `DAQ_DB_Transfer` to transfer old data into a second buffer before it is overwritten by new data.

`DAQ_DB_Transfer` transfers data out of one half of the buffer while the other half is filled with new data.

Data Acquisition Timing

A direct digital synthesis (DDS) clock generation circuit generates an extremely stable clock signal that can drive the converters at scan rates up to 204.8 kHz in increments of 200 μ Hz. The antialiasing filter in the converter adjusts to the scan rate to reject frequency components from frequencies above the scan rate. Because the converters require the stability of the DDS clock, you cannot supply an external clock. Clock signals can be synchronized between multiple PCI-445X and PCI-455X devices over the RTSI bus.

You can configure a data acquisition operation to use the following trigger signals:

- A *start trigger* is a signal that initiates a data acquisition sequence. You can supply this signal externally through a selected I/O connector pin, through a RTSI bus trigger line, or by software.
- A *stop trigger* is a signal used for pretriggered data acquisition to notify your device to stop acquiring data after a specified number of scans. Data acquisition operation is continuously performed until the device receives this signal. This signal can be supplied externally through a selected I/O connector pin, through a RTSI bus trigger line, or by software.

There are two hardware trigger sources— analog or digital. The device can receive the analog trigger from any one of the input channels, even if that channel is not included in the scan list of the acquisition. The analog trigger circuitry generates a trigger when the selected input channel reaches a specified slope and level. If you want a digital trigger, you can configure the device to receive the trigger from the digital I/O connector or from the RTSI bus.

When using a digital trigger, notice that the first sample after the trigger does not appear in the acquisition buffer until 42 scans have been acquired. This means that in posttrigger mode the acquisition buffer contains 42 pretrigger samples when the acquisition is finished. This behavior is a feature of the digital antialiasing filter in the converter and cannot be disabled.

PCI-4451 and PCI-4551 Analog Output Channels

The PCI-4451 and PCI-4551 devices contain simultaneously updated analog output channels based on delta-sigma DACs. The converters accept 18-bit resolution samples. Each channel also has software configurable attenuation settings of 0, 20, and 40 dB.

The converters continuously generate samples while the update clock is running. A direct digital synthesis (DDS) clock generation circuit generates an extremely stable clock signal that can drive the converters at update rates up to 51.2 kHz in increments of 200 μ Hz. The antiimaging filter in the converters adjusts to the update rate to reject frequency components from frequencies above the update rate. Because the converters require the stability of the DDS clock, you cannot supply an external clock. Clock signals can be synchronized between multiple PCI-445X and PCI-455X devices over the RTSI bus.

Waveform Generation

The waveform generation (`WFM`) functions can write values to either one or both analog output channels continuously using the onboard DDS clock to update the DACs at regular intervals. The values are contained in a buffer that you allocate and fill. The resultant voltages produced at the analog output channels depend on the value of the numbers in the buffer.

DSA devices accept data values in a left-justified 32-bit data format. This means that the most significant bits of the data value contain the bits that will be written to the converter. Even though the `WFM` functions are declared to accept pointers to 16-bit data buffers, you should pass the pointers to 32-bit data buffers for the DSA devices.

The DDS clock signal is shared by the input and the output sections of the device. The ADCs and DACs have separate internal divides of the DDS clock, so that at the maximum DDS rate the input ADCs run at four times the sample rate of the DACs. The device does have an independent divide down circuit for each analog section, so that you can adjust the DDS clock by powers of two. This circuitry allows you to set the rate for both the ADCs and DACs to the same scan clock rate. The `WFM_Set_Clock` function automatically makes this adjustment and tries to make a setting compatible with the analog input clock setting mode. If a data acquisition operation is already running, the waveform clock is constrained to frequencies compatible with the data acquisition clock.

You can configure the waveform generation to start when the device receives a digital trigger. The device can receive the digital trigger from either the digital I/O connector or the RTSI bus. Notice that the first update after the trigger does not appear at the outputs until 30 to 40 updates have been generated. This behavior is a feature of the digital antiimaging filter in the converter and cannot be disabled.

PCI-445X and PCI-455X Digital I/O

PCI-445X Digital I/O

The PCI-445X devices contain one 8-bit digital I/O port supplied by the DAQ-STC chip. This port is referred to as port 0 by the Digital I/O functions.

You can configure the entire digital port as either an input or an output port, or you can configure individual lines for either input or output. The port has *read-back capability*. This port operates in nonlatched mode only.

PCI-455X Digital I/O

The PCI-455X devices contain four 8-bit digital I/O ports supplied by the DAQ-TIO chip. These ports are referred to as ports 0 through 3 by the Digital I/O functions.

You can configure each port entirely as either an input or an output port, or you can configure individual lines for either input or output. Each port and line has read-back capability, and these ports operate in nonlatched mode only.



Note

The pins on the I/O connector that correspond to digital port 3 are the same pins that correspond to the inputs and outputs of the two general-purpose counters. Thus, if you configure any lines of port 3 for digital input or output, you disable the counters from using the lines as input or output signals if a counter operation has been previously configured. Similarly, enabling the counter input and output signals disables the digital signals on the corresponding lines. National Instruments recommends that you do not use digital port 3 if you are using counters and vice versa.

PCI-445X and PCI-455X Counter/Timer Operation

PCI-445X Counter/Timers

The PCI-445X devices use the National Instruments DAQ-STC counter/timer chip. The DAQ-STC has two 24-bit counter/timers that are always available for general-purpose counter/timer applications. Refer to the GPCTR functions in Chapter 2, *Function Reference*, of the *NI-DAQ Function Reference Manual for PC Compatibles* for more information.

PCI-455X Counter/Timers

The PCI-455X devices use the National Instruments DAQ-TIO counter/timer chip. The DAQ-TIO has two 32-bit counter/timers that are always available for general-purpose counter/timer applications. Refer to the GPCTR functions in Chapter 2, *Function Reference*, of the *NI-DAQ Function Reference Manual for PC Compatibles* for more information.

671X Devices

Chapter
21

This chapter contains overview information on the PCI-671X devices, including the PCI-6711, PCI-6713, PXI-6711, PXI-6713, and DAQPad-6713. For more detailed descriptions of the hardware functionality and specifications, refer to your device user manual.

671X Device Analog Output

The 671X devices contain four or eight analog output channels numbered 0 through 7. Each analog output channel contains a 12-bit DAC, which is always configured in bipolar mode. An onboard voltage reference of +10 V is available for the analog output channels. An external reference voltage signal can also drive the analog output channels. See the `AO_Configure` function in Chapter 2, *Function Reference*, of the *NI-DAQ Function Reference Manual for PC Compatibles* for more information about configuring the DACs.

**Note**

The 671X devices require an even number of samples in the waveform buffer due to FIFO requirements necessary for high-speed data transfers.

671X Device Waveform Generation

Timing and control on the 671X devices is performed by the National Instruments Data Acquisition System Timing Controller (DAQ-STC) chip. The Waveform Generation functions can write values to either one or more analog output channels continuously using an onboard or external clock to update the DACs at regular intervals. The values are contained in a buffer that you allocate and fill. The resultant voltages produced at the analog output channels depend on the value of the numbers in the buffer and the level of the reference voltage.

**Note**

*NI-DAQ can use either DMA or interrupt service routines to generate waveforms on the analog output channels. By default, NI-DAQ uses DMA because DMA is simply more efficient. Call `Set_DAQ_Device_Info`, described in Chapter 2, *Function Reference*, of the *NI-DAQ Function Reference Manual for PC Compatibles*, to force NI-DAQ not to use DMA for waveform generation.*

671X Waveform Generation Using Onboard Memory

All 671X devices support FIFO mode waveform generation. In this mode, waveform data is transferred to the onboard DAC FIFO memory only once. These values are then cycled through to generate the waveform continuously or for a finite number of iterations. No interrupt service or DMA operation is required to transfer more data to the device during waveform generation.

The following conditions must be satisfied to use FIFO mode waveform generation:

- One cycle worth of waveform data can be held entirely on the device DAC FIFO memory.
- Double-buffered waveform generation mode is disabled.
- The number of cycles to generate can be infinite (denoted by the value 0), or between 1 and 16,777,216 inclusive.

There are two variations possible in FIFO mode waveform generation:

- Continuous cyclic waveform generation—An onboard counter or an external signal provides the update pulses. Once started, the waveform generation continues until you call the clear function (`WFM_Group_Control`) to stop the waveform.
- Programmed cyclic waveform generation—An onboard counter or an external signal provides the update pulses. A separate onboard counter terminates the waveform after a finite number of cycles has been generated.

Refer to your DAQ device manual to determine the size of the analog output FIFO and for more information on waveform generation.

671X Digital I/O

The 671X devices contain one 8-bit digital I/O port supplied by the DAQ-STC chip. This port is referred to as port 0 by the Digital I/O functions.

You can configure the entire digital port as either an input or an output port, or you can configure individual lines for either input or output. The port has *read-back capability*. This port operates in nonlatched mode only.

**Note**

Connecting a non-remote SCXI chassis to a 671X device renders various lines of the digital I/O port unavailable:

SCXI—Lines 0, 1, 2, and 4 are unavailable.

The remaining lines of the digital I/O port are available for input or output. Use DIG_Line_Config to configure these remaining lines.

671X Counter/Timer Operation

The 671X devices use the National Instruments DAQ-STC counter/timer chip. The DAQ-STC has two 24-bit counter/timers that are always available for general-purpose counter/timer applications. Refer to the GPCTR functions in Chapter 2, *Function Reference*, of the *NI-DAQ Function Reference Manual for PC Compatibles* for more information.

671X Programmable Frequency Output Operation

The 671X devices have one I/O connector pin (FREQ_OUT) capable of outputting a programmable frequency signal. This signal is a divided-down version of the selected timebase. Available timebases are 10 MHz and 100 kHz, and you can divide them by numbers 1 through 16.

671X PFI Pins

You can route internal device signals to and from the I/O connector programmatically by using the PFI pins on the 671X devices. Refer to your 671X device user manual for a complete discussion of PFI pins.

Customer Communication

For your convenience, this appendix contains forms to help you gather the information necessary to help us solve your technical problems and a form you can use to comment on the product documentation. When you contact us, we need the information on the Technical Support Form and the configuration form, if your manual contains one, about your system configuration to answer your questions as quickly as possible.

National Instruments has technical assistance through electronic, fax, and telephone systems to quickly provide the information you need. Our electronic services include a bulletin board service, an FTP site, a fax-on-demand system, and e-mail support. If you have a hardware or software problem, first try the electronic support systems. If the information available on these systems does not answer your questions, we offer fax and telephone support through our technical support centers, which are staffed by applications engineers.

Electronic Services

Bulletin Board Support

National Instruments has BBS and FTP sites dedicated for 24-hour support with a collection of files and documents to answer most common customer questions. From these sites, you can also download the latest instrument drivers, updates, and example programs. For recorded instructions on how to use the bulletin board and FTP services and for BBS automated information, call 512 795 6990. You can access these services at:

United States: 512 794 5422

Up to 14,400 baud, 8 data bits, 1 stop bit, no parity

United Kingdom: 01635 551422

Up to 9,600 baud, 8 data bits, 1 stop bit, no parity

France: 01 48 65 15 59

Up to 9,600 baud, 8 data bits, 1 stop bit, no parity

FTP Support

To access our FTP site, log on to our Internet host, `ftp.natinst.com`, as anonymous and use your Internet address, such as `joesmith@anywhere.com`, as your password. The support files and documents are located in the `/support` directories.

Fax-on-Demand Support

Fax-on-Demand is a 24-hour information retrieval system containing a library of documents on a wide range of technical information. You can access Fax-on-Demand from a touch-tone telephone at 512 418 1111.

E-Mail Support (Currently USA Only)

You can submit technical support questions to the applications engineering team through e-mail at the Internet address listed below. Remember to include your name, address, and phone number so we can contact you with solutions and suggestions.

support@natinst.com

Telephone and Fax Support

National Instruments has branch offices all over the world. Use the list below to find the technical support number for your country. If there is no National Instruments office in your country, contact the source from which you purchased your software to obtain support.

Country	Telephone	Fax
Australia	03 9879 5166	03 9879 6277
Austria	0662 45 79 90 0	0662 45 79 90 19
Belgium	02 757 00 20	02 757 03 11
Brazil	011 288 3336	011 288 8528
Canada (Ontario)	905 785 0085	905 785 0086
Canada (Quebec)	514 694 8521	514 694 4399
Denmark	45 76 26 00	45 76 26 02
Finland	09 725 725 11	09 725 725 55
France	01 48 14 24 24	01 48 14 24 14
Germany	089 741 31 30	089 714 60 35
Hong Kong	2645 3186	2686 8505
Israel	03 6120092	03 6120095
Italy	02 413091	02 41309215
Japan	03 5472 2970	03 5472 2977
Korea	02 596 7456	02 596 7455
Mexico	5 520 2635	5 520 3282
Netherlands	0348 433466	0348 430673
Norway	32 84 84 00	32 84 86 00
Singapore	2265886	2265887
Spain	91 640 0085	91 640 0533
Sweden	08 730 49 70	08 730 43 70
Switzerland	056 200 51 51	056 200 51 55
Taiwan	02 377 1200	02 737 4644
United Kingdom	01635 523545	01635 523154
United States	512 795 8248	512 794 5678

Technical Support Form

Photocopy this form and update it each time you make changes to your software or hardware, and use the completed copy of this form as a reference for your current configuration. Completing this form accurately before contacting National Instruments for technical support helps our applications engineers answer your questions more efficiently.

If you are using any National Instruments hardware or software products related to this problem, include the configuration forms from their user manuals. Include additional pages if necessary.

Name _____

Company _____

Address _____

Fax (____) _____ Phone (____) _____

Computer brand _____ Model _____ Processor _____

Operating system (include version number) _____

Clock speed _____ MHz RAM _____ MB Display adapter _____

Mouse ___yes ___no Other adapters installed _____

Hard disk capacity _____ MB Brand _____

Instruments used _____

National Instruments hardware product model _____ Revision _____

Configuration _____

National Instruments software product _____ Version _____

Configuration _____

The problem is: _____

List any error messages: _____

The following steps reproduce the problem: _____

NI-DAQ for PC Compatibles Hardware and Software Configuration Form

Record the settings and revisions of your hardware and software on the line to the right of each item. Complete a new copy of this form each time you revise your software or hardware configuration, and use this form as a reference for your current configuration. Completing this form accurately before contacting National Instruments for technical support helps our applications engineers answer your questions more efficiently.

National Instruments Products

DAQ hardware _____

Interrupt level of hardware _____

DMA channels of hardware _____

Base I/O address of hardware _____

Programming choice _____

National Instruments software version _____

Other boards in system _____

Base I/O address of other boards _____

DMA channels of other boards _____

Interrupt level of other boards _____

Other Products

Computer make and model _____

Microprocessor _____

Clock frequency or speed _____

Type of video board installed _____

Operating system version _____

Operating system mode _____

Programming language _____

Programming language version _____

Other boards in system _____

Base I/O address of other boards _____

DMA channels of other boards _____

Interrupt level of other boards _____

Documentation Comment Form

National Instruments encourages you to comment on the documentation supplied with our products. This information helps us provide quality products to meet your needs.

Title: *DAQ Hardware Overview Guide*

Edition Date: October 1998

Part Number: 321646D-01

Please comment on the completeness, clarity, and organization of the manual.

If you find errors in the manual, please record the page numbers and describe the errors.

Thank you for your help.

Name _____

Title _____

Company _____

Address _____

Phone (____) _____ Fax (____) _____

Mail to: Technical Publications
National Instruments Corporation
6504 Bridge Point Parkway
Austin, TX 78730-5039

Fax to: Technical Publications
National Instruments Corporation
(512) 794-5678

Prefix	Meaning	Value
μ -	micro-	10^{-6}
m-	milli-	10^{-3}
k-	kilo-	10^3
M-	mega-	10^6

Numbers/Symbols

α	temperature coefficient at $T = 0^{\circ} \text{C}$
β	coefficient
∂	coefficient
ϵ	strain
Ω	ohm
$^{\circ}$	degree
%	percent
+	plus
-	minus
\pm	plus or minus
>	greater than

A

AC	alternating current
ACK	acknowledge
A/D	analog-to-digital
ADC	A/D converter. An electronic device, often an integrated circuit, that converts an analog voltage to a digital number.
ADC resolution	The resolution of the ADC, which is measured in bits. An ADC with 16 bits has a higher resolution, and thus a higher degree of accuracy, than a 12-bit ADC.
ADF	adapter description file
AI	analog input
AMD	Advanced Micro Devices
analog trigger	A trigger that occurs at a user-selected point on an incoming analog signal. Triggering can be set to occur at a specific level on either an increasing or a decreasing signal (positive or negative slope). Analog triggering can be implemented either in software or in hardware. When implemented in software (LabVIEW), all data is collected, transferred into system memory, and analyzed for the trigger condition. When analog triggering is implemented in hardware, no data is transferred to system memory until the trigger condition has occurred.
API	application programming interface
asynchronous	(1) Hardware—A property of an event that occurs at an arbitrary time, without synchronization to a reference clock. (2) Software—A property of a function that begins an operation and returns prior to the completion or termination of the operation.

B

background acquisition	Data is acquired by a DAQ system while another program or processing routine is running without apparent interruption.
base address	A memory address that serves as the starting address for programmable registers. All other addresses are located by adding to the base address.
BCD	binary-coded decimal
BIOS	basic input/output system
bipolar	A signal range that includes both positive and negative values (for example, -5 V to $+5\text{ V}$).
bit	One binary digit, either 0 or 1.
block-mode	A high-speed data transfer in which the address of the data is sent followed by a specified number of back-to-back data words.
buffer	temporary storage for acquired or generated data (software)
bus	The group of conductors that interconnect individual circuitry in a computer. Typically, a bus is the expansion vehicle to which I/O or other devices are connected. Examples of PC buses are the AT bus, NuBus, Micro Channel, and EISA bus.
byte	Eight related bits of data, an 8-bit binary number. Also used to denote the amount of memory required to store one byte of data.

C

C	Celsius
CI	computing index
cold-junction compensation	A method of compensating for inaccuracies in thermocouple circuits.
compiler	A software utility that converts a source program in a high-level programming language, such as BASIC, C, or Pascal, into an object or compiled program in machine language. Compiled programs run 10 to 1,000 times faster than interpreted programs.

conversion	A signal that initiates individual A/D conversions.
conversion pulse	A signal that generates a pulse once every sample interval, initiating an A/D conversion.
conversion time	The time required, in an analog input or output system, from the moment a channel is interrogated (such as with a read instruction) to the moment that accurate data is available.
counter/timer	A circuit that counts external pulses or clock pulses (timing).
coupling	The manner in which a signal is connected from one location to another.
CPU	central processing unit

D

D/A	digital-to-analog
DAC	D/A converter. An electronic device, often an integrated circuit, that converts a digital number into a corresponding analog voltage or current.
DAQ	Data acquisition. (1) Collecting and measuring electrical signals from sensors, transducers, and test probes or fixtures and inputting them to a computer for processing. (2) Collecting and measuring the same kinds of electrical signals with A/D and/or DIO boards plugged into a PC, and possibly generating control signals with D/A and/or DIO boards in the same PC.
DAQ-STC	Data acquisition system timing controller. An application-specific integrated circuit (ASIC) for the system timing requirements of a general A/D and D/A system, such as a system containing the National Instruments E Series boards.
DC	direct current
DDS	Direct Digital Synthesis
device	Device is used to refer to a DAQ device inside your computer or attached directly to your computer via a parallel port. Plug-in boards, PCMCIA cards, and devices such as the DAQPad-1200, which connects to your computer parallel port, are all examples of DAQ devices. SCXI modules are distinct from devices, with the exception of the SCXI-1200 and SCXI-2400, which are hybrids.

differential input	An analog input consisting of two terminals, both of which are isolated from computer ground, whose difference is measured.
digital port	<i>See</i> port.
DIN	Deutsche Industrie Norme
DIO	digital I/O
DLL	Dynamic-link library. A software module in Microsoft Windows containing executable code and data that can be called or used by Windows applications or other DLLs. Functions and data in a DLL are loaded and linked at run time when they are referenced by a Windows application or other DLLs.
DMA	Direct memory access. A method by which data can be transferred to/from computer memory from/to a device or memory on the bus while the processor does something else. DMA is the fastest method of transferring data to/from computer memory.
driver	Software that controls a specific hardware device such as a DAQ board or a GPIB interface board.
DSA	Dynamic Signal Acquisition
DSP	digital signal processing
E	
EEPROM	Electrically erasable programmable read-only memory. ROM that can be erased with an electrical signal and reprogrammed.
EGA	enhanced graphics adapter
EISA	Extended Industry Standard Architecture
external trigger	A voltage pulse from an external source that triggers an event such as A/D conversion.

F

FIFO A first-in first-out memory buffer; the first data stored is the first data sent to the acceptor. FIFOs are often used on DAQ devices to temporarily store incoming or outgoing data until that data can be retrieved or output. For example, an analog input FIFO stores the results of A/D conversions until the data can be retrieved into system memory, a process that requires the servicing of interrupts and often the programming of the DMA controller. This process can take several milliseconds in some cases. During this time, data accumulates in the FIFO for future retrieval. With a larger FIFO, longer latencies can be tolerated. In the case of analog output, a FIFO permits faster update rates, because the waveform data can be stored on the FIFO ahead of time. This again reduces the effect of latencies associated with getting the data from system memory to the DAQ device.

G

gain The factor by which a signal is amplified, sometimes expressed in decibels.

gate A signal used for gating the data acquisition.

group A collection of digital ports, combined to form a larger entity for digital input and/or output.

H

Hz hertz

I

IBM International Business Machines

ID identification

IDE Integrated Development Environment

IEEE Institute of Electrical and Electronics Engineers

interrupt A computer signal indicating that the CPU should suspend its current task to service a designated activity.

I/O	input/output
IRQ	interrupt request
ISA	Industry Standard Architecture

K

kS	1,000 samples
Kword	1,024 words of memory

L

LED	light-emitting diode
library	A file containing compiled object modules, each comprised of one or more functions, that can be linked to other object modules that make use of these functions. <code>NIDAQMSC.LIB</code> is a library that contains NI-DAQ functions. The NI-DAQ function set is broken down into object modules so that only the object modules that are relevant to your application are linked in, while those object modules that are not relevant are not linked.
linker	A software utility that combines object modules (created by a compiler) and libraries, which are collections of object modules, into an executable program.
LSB	least significant bit

M

MB	megabytes of memory
MIO	multifunction I/O
MS	million samples
multiplexed mode	an SCXI operating mode in which analog input channels are multiplexed into one module output so that your cabled DAQ device has access to the module's multiplexed output as well as the outputs on all other multiplexed modules in the chassis through the SCXI bus. Also called serial mode.

mux Multiplexer; a switching device with multiple inputs that sequentially connects each of its inputs to its output, typically at high speeds, in order to measure several signals with a single analog input channel.

N

NBS National Bureau of Standards

NC Normally Closed

NIVDMAD National Instruments Virtual DMA Driver

NIVISRDR National Instruments Virtual Interrupt Service Routine Driver.

NO normally open

O

output settling time The amount of time required for the analog output voltage to reach its final value within specified limits.

P

paging A technique used for extending the address range of a device to point into a larger address space.

parallel mode a type of SCXI operating mode in which the module sends each of its input channels directly to a separate analog input channel of the device to the module

PC personal computer

PCLK peripheral clock signal. The clock signal used to synchronize a 6533 (DIO-32HS) device to a peripheral in the burst-mode handshaking protocol.

port A digital port, consisting of four or eight lines of digital input and/or output.

posttriggering The technique used on a DAQ board to acquire a programmed number of samples after trigger conditions are met.

pretriggering	The technique used on a DAQ board to keep a continuous buffer filled with data, so that when the trigger conditions are met, the sample includes the data leading up to the trigger condition.
programmed I/O	The standard method a CPU uses to access an I/O device—each byte of data is read or written by the CPU.
pts	points
PXI	PCI eXtensions for Instrumentation.

R

RAM	random-access memory
read-back capability	The ability to read a port, associated to a particular line, to determine the digital value the output line is asserting.
remote SCXI	An SCXI configuration in which a serial port cable is connected to an SCXI-2000 chassis or an SCXI-100X chassis with an SCXI-2400 remote communications module. Multiple remote SCXI units can be connected to one serial port in a PC by using RS-485. You can use either an RS-485 interface card in your PC or an RS-485 converter on the RS-232 port.
REQ	request signal
resolution	The smallest signal increment that can be detected by a measurement system. Resolution can be expressed in bits, in proportions, or in percent of full scale. For example, a system has 12-bit resolution, one part in 4,096 resolution, and 0.0244 percent of full scale.
ROM	read-only memory
RMS	root mean squared
RTD	Resistance temperature detector. A metallic probe that measures temperature based upon its coefficient of resistivity.
RTSI	Real-Time System Integration (bus). The National Instruments timing bus that connects DAQ boards directly, for precise synchronization of functions.

S

s	seconds
S	samples
Sample-and-Hold (S/H)	A circuit that acquires and stores an analog voltage on a capacitor for a short period of time.
sample counter	A counter used to tally the number of A/D conversions (samples), generated either by the onboard sample-interval counter or externally, and shuts down the data acquisition timing circuitry when the number of samples you want have been acquired.
sample interval	An interval that indicates the time to elapse between A/D conversions on each channel in the sequence.
sample-interval timer	A counter that you can use for conversion timing.
sample-interval timer timebase	A signal used by the sample interval timer for conversion timing. This signal is only used when the sample interval timer is used.
scan counter	A counter used to control the number of scans you acquire.
scan interval pulse	A signal that generates a pulse every scan.
scan timer	A counter you can use for start scan timing.
SCMP	Signal Conditioning Minipods
SCXI	Signal Conditioning eXtensions for Instrumentation; the National Instruments product line for conditioning low-level signals within an external chassis near sensors.
self-calibrating	A property of a DAQ board that has an extremely stable onboard reference and calibrates its own A/D and D/A circuits without manual adjustments by the user.
serial mode	<i>See</i> multiplexed mode.
Single-Ended (SE) Inputs	An analog input that is measured with respect to a common ground.
software trigger	A programmed event that triggers an event such as data acquisition.

S/s	Samples per second; used to express the rate at which a DAQ board samples an analog signal.
start scan	A signal that initiates individual scans.
start trigger	An edge-triggered signal that initiates a data acquisition sequence.
STC	System Timing Controller
stop trigger	A signal used for pretriggered data acquisition to notify your device to stop acquiring data after a specified number of samples or scans.
synchronous	(1) Hardware—A property of an event that is synchronized to a reference clock. (2) Software—A property of a function that begins an operation and returns only when the operation is complete.

T

TC	terminal count
timebase clock	A clock signal that is the time base for the sample-interval counter.
transfer rate	The rate, measured in bytes/s, at which data is moved from source to destination after software initialization and set up operations; the maximum rate at which the hardware can operate.

U

unipolar	A signal range that is always positive (for example, 0 to +10 V).
----------	---

V

V	volts
VDC	volts direct current
VPICD	Virtual Programmable Interrupt Controller Device
V_{RMS}	volts root mean squared
VXI	VMEbus eXtensions for Instrumentation.

X

XMS extended memory specification

Numbers

445X and 455X devices. *See* PCI-445X and PCI-455X devices.

516 devices and DAQCard 500/700

analog input, 4-1 to 4-3

data acquisition, 4-2 to 4-3

data acquisition timing, 4-2 to 4-3

digital I/O, 4-3

interval counter/timer operation, 4-4 to 4-5

counter timers, 4-4 to 4-5

counter/timer signal connections (figures), 4-4, 4-5

1200 devices. *See* Lab and 1200 devices.

6025E devices

available ports (table), 1-10

digital I/O, 9-1

groups of ports, 9-2

port 0, 1-9, 9-1

port numbers (table), 9-1

611X devices

AMUX-64T and SCXI modes not supported (note), 1-4

scan interval counter (note), 1-7

scan interval limits (note), 1-4

6704 devices, 6-1

671X devices. *See* PCI-671X and PXI-671X devices.

A

AI multifunction I/O devices. *See* MIO and AI multifunction devices.

Am9513-based devices

counter block diagram, 7-1

counter/timer operation, 7-1 to 7-4

gating modes, 7-2

internal timebases, 7-1 to 7-2

PC-TIO-10 counter/timers, 7-5

programmable frequency output operation, 7-4

timebases, 7-1 to 7-2

timing and output types (figure), 7-4

AMUX-64T external multiplexers, 11-1 to 11-5

analog input channel range (table), 11-1

channel numbers (table), 11-2

numbering of analog input channels (notes), 11-5

port unavailability with connection to SCXI chassis or E Series device (note), 1-9

purpose and use, 11-1 to 11-2

scanning order, 11-2 to 11-5

for MIO or AI devices (table), 11-3 to 11-4

AMUX-64T mode, E Series, 1-5

analog input

516 devices and DAQCard 500/700, 4-1 to 4-3

data acquisition, 4-2 to 4-3

data acquisition timing, 4-2 to 4-3

E Series data acquisition, 1-3 to 1-5

data acquisition rates, 1-7

timing and control, 1-5 to 1-7

Lab and 1200 devices, 2-1 to 2-6

data acquisition, 2-2 to 2-6

FIFO size (table), 2-2

- LPM devices, 3-1 to 3-3
 - data acquisition, 3-1 to 3-3
 - data acquisition rates, 3-3
 - data acquisition timing, 3-2
 - MIO and AI multifunction devices,
 - 1-1 to 1-10
 - analog input characteristics (table), 1-1 to 1-3
 - E Series data acquisition, 1-3 to 1-5
 - NI 40XX device, 19-1 to 19-2
 - NI 435X device, 18-1 to 18-3
 - PCI-445X and PCI-455X devices, 20-1 to 20-3
 - data acquisition, 20-2 to 20-3
 - data acquisition timing, 20-3
 - analog output
 - AT-AO-6/10 boards, 5-1 to 5-2
 - Lab and 1200 devices, 2-6
 - MIO and AI multifunction devices, 1-7 to 1-9
 - E Series waveform generation, 1-8 to 1-9
 - MIO device waveform generation, 1-8
 - PCI-445X and PCI-455X devices, 20-4 to 20-5
 - PCI-671X and PXI-671X devices, 21-1
 - VXI-AO-48XDC analog output board, 15-2 to 15-3
 - AT-AO-6/10 boards
 - analog output, 5-1 to 5-2
 - digital I/O, 5-3
 - hardware restrictions, 5-2
 - waveform generation, 5-1
 - using onboard memory, 5-1 to 5-2
 - AT-MIO-16DE-10
 - available ports (table), 1-10
 - digital I/O, 9-1
 - groups of ports, 9-2
 - port 0, 1-9, 9-1
 - port numbers (table), 9-1
- B**
- bulletin board support, A-1
- C**
- calibration for Lab and 1200 devices, 2-9 to 2-10
 - conversion pulse signal
 - 516 devices and DAQCard 500/700, 4-3
 - Lab and 1200 devices, 2-4
 - LPM devices, 3-2
 - conversion signal, E Series, 1-6
 - counter/timers. *See also* data acquisition timing; interval counter/timer operation.
 - 516 devices and DAQCard 500/700, 4-2 to 4-3
 - E Series, 1-10
 - PFI pins, 1-10
 - programmable frequency output operation, 1-10
 - Lab and 1200 devices, 2-4
 - LPM devices, 3-2
 - PCI-445X and PCI-455X devices, 20-6
 - PCI-671X and PXI-671X devices, 21-3
 - PC-TIO-10 timing I/O board, 7-1 to 7-5
 - Am9513-based device operation, 7-1 to 7-4
 - counter/timers, 7-5
 - programmable frequency output operation, 7-4
 - current source, NI 435X device, 18-4
 - customer communication, xx, A-1 to A-2
- D**
- DAQCard-500/700. *See* 516 devices and DAQCard 500/700.
 - DAQCard-1200. *See also* Lab and 1200 devices.
 - calibration, 2-9 to 2-10
 - data acquisition rate, 2-9

- DAQCard-4350. *See* NI 435X devices.
- DAQDIO 6533. *See* DIO-32F and DAQDIO 6533 (DIO-32HS).
- DAQPad-1200. *See also* Lab and 1200 devices.
 - calibration, 2-9 to 2-10
 - data acquisition rate, 2-9
 - printer connection, 2-9
- data acquisition
 - 516 devices and DAQCard 500/700, 4-2 to 4-3
 - E Series, 1-3 to 1-5
 - Lab and 1200 devices, 2-2 to 2-3
 - LPM devices, 3-1 to 3-3
 - NI 40XX devices, 19-2
 - NI 435X device, 18-2 to 18-3
 - PCI-445X and PCI-455X devices, 20-2 to 20-3
- data acquisition filtering, NI 40XX devices, 19-2 to 19-3
- data acquisition rates
 - E Series, 1-7
 - Lab and 1200 devices, 2-5 to 2-6, 2-9
 - LPM devices, 3-3
- data acquisition timing
 - 516 devices and DAQCard 500/700, 4-2 to 4-3
 - E Series, 1-5 to 1-7
 - Lab and 1200 devices, 2-4 to 2-5
 - LPM devices, 3-2
 - NI 40XX devices, 19-2 to 19-3
 - NI 435X device, 18-3
 - PCI-445X and PCI-455X devices, 20-3
- DDS (Direct Digital Synthesizer) mode, NI 5411 devices, 17-3 to 17-4
- digital I/O
 - 516 devices and DAQCard 500/700, 4-3
 - 6025E devices, 9-1
 - AT-AO-6/10 boards, 5-3
 - AT-MIO-16DE-10, 9-1
 - DIO-24, 9-1
 - DIO-32F and DAQDIO 6533 (DIO-32HS), 10-1 to 10-3
 - DIO-96 boards, 8-1 to 8-3
 - E Series, 1-9 to 1-10
 - Lab and 1200 devices, 2-6 to 2-7
 - LPM devices, 3-3
 - NI 435X devices, 18-4
 - PCI-445X and PCI-455X devices, 20-5
 - PCI-671X and PXI-671X devices, 21-2 to 21-3
 - PCI-6704 analog output board, 6-1
 - PC-TIO-10 timing I/O board, 7-5
 - PXI-6704 analog output board, 6-1
 - VXI-AO-48XDC analog output board, 15-3
 - VXI-DIO-128 Digital I/O board, 15-2
- DIO-24
 - digital I/O, 9-1
 - groups of ports, 9-2
 - port numbers (table), 9-1
 - SCXI support, 14-20 to 14-21
- DIO-32F and DAQDIO 6533 (DIO-32HS)
 - digital I/O, 10-1 to 10-3
 - extra inputs and outputs (table)
 - DAQDIO 6533 (DIO-32HS), 10-3
 - DIO-32F, 10-2
 - ports, 10-1 to 10-2
 - SCXI support, 14-21 to 14-22
- DIO-96 boards
 - digital I/O, 8-1 to 8-3
 - groups, 8-3
 - port labels, numbers, and modes (table), 8-1 to 8-2
 - support for SCXI modules, 14-20 to 14-21
- Direct Digital Synthesizer (DDS) mode, NI 5411 devices, 17-3 to 17-4
- documentation
 - conventions used in manual, *xv-xviii*
 - MIO and AI device terminology (table), *xviii-xx*

- organization of manual, *xiii-xv*
- related documentation, *xx*

double-buffered mode

- 516 devices and DAQCard 500/700, 4-2
- E Series, 1-4
- Lab and 1200 devices, 2-3
- LPM devices, 3-2
- PCI-445X and PCI-455X, 20-3

DSA Devices. *See* PCI-445X and PCI-455X devices.

E

E Series

- counter/timer operation, 1-10
 - PFI pins, 1-10
 - programmable frequency output operation, 1-10
- data acquisition, 1-3 to 1-5
- data acquisition rates, 1-7
- data acquisition timing, 1-5 to 1-7
- digital I/O, 1-9 to 1-10
 - AT-MIO-16DE-10 and 6025E device ports (table), 1-10
 - connecting one or more AMUX-64T devices or SCXI chassis (note), 1-9
- waveform generation using onboard memory, 1-8 to 1-9

electronic support services, A-1 to A-2

e-mail support, A-2

EXTCONV* input, Lab and 1200 devices, 2-1

F

- fax and telephone support numbers, A-2
- Fax-on-Demand support, A-2
- FIFO mode waveform generation, PCI-671X and PXI-671X devices, 21-2
- filtering, NI 40XX devices, 19-2 to 19-3
- FTP support, A-1

G

- gate signal, E Series, 1-6
- gating modes, Am9513-based devices, 7-2

groups of ports

- DIO-24, AT-MIO-16DE-10, and 6025E, 9-2
- DIO-96 boards, 8-3
- Lab and 1200 devices, 2-7

H

half-FIFO mode

- DAQCard-700 (note), 4-2
- DAQPad-MIO-16XE-50 (note), 1-5
- Lab and 1200 devices (note), 2-5
- PCI E-Series and DAQCard E-Series devices (note), 1-5

I

interval counter/timer operation. *See also* counter/timers.

- 516 devices and DAQCard 500/700, 4-4 to 4-5
 - counter timers, 4-4 to 4-5
 - counter/timer signal connections (figures), 4-4, 4-5
- Lab and 1200 devices, 2-7 to 2-9
 - block diagram, 2-7
 - counter/timer signal connections (figure), 2-8
 - counter/timers, 2-8 to 2-9
- LPM devices, 3-3 to 3-4
 - counter/timer signal connections (figure), 3-4
 - counter/timers, 3-4

interval scanning, Lab and 1200 devices, 2-2

L

Lab and 1200 devices

- analog input, 2-1 to 2-6
- analog output, 2-6
- calibration, 2-9 to 2-10
- DAQPad-1200 printer connection, 2-9
- data acquisition, 2-2 to 2-3
- data acquisition rate, 2-9
- data acquisition rates, 2-5 to 2-6
- data acquisition timing, 2-4 to 2-5
- digital I/O, 2-6 to 2-7
- groups of ports, 2-7
- interval counter/timer operation, 2-7 to 2-9
 - block diagram, 2-7
 - counter/timer signal connections (figure), 2-8
 - counter/timers, 2-8 to 2-9
- pretrigger mode, 2-3
- SCXI support, 14-19 to 14-20
- waveform generation, 2-6

LPM devices

- analog input, 3-1 to 3-3
- data acquisition, 3-1 to 3-3
- data acquisition rates, 3-3
- data acquisition timing, 3-2
- digital I/O, 3-3
- interval counter/timer operation, 3-3 to 3-4
 - counter/timer signal connections (figure), 3-4
 - counter/timers, 3-4

M

manual. *See* documentation.

MIO and AI multifunction devices

- analog input, 1-1 to 1-10
 - analog input characteristics (table), 1-1 to 1-3
 - E Series data acquisition, 1-3 to 1-5

- E Series data acquisition rates, 1-7

- E Series data acquisition timing, 1-5 to 1-7

analog output

- E Series waveform generation, using onboard memory, 1-8 to 1-9

- MIO device waveform generation, 1-8

- E Series counter/timer operation, 1-10

- E Series digital I/O, 1-9 to 1-10

- MIO device analog output, 1-7 to 1-9
- terminology (table), xviii-xx

multiple-channel scanned data acquisition

- 516 devices and DAQCard 500/700, 4-2

- E Series, 1-3

- Lab and 1200 devices, 2-2

- LPM devices, 3-1 to 3-2

- NI 435X, 18-2

multiplexed mode for SCXI modules

- analog input modules, 14-2 to 14-3

- analog output modules, 14-4

- digital and relay modules, 14-4

- SCXI-1200, 14-3 to 14-4

N

NI 40XX devices, 19-1 to 19-3

- data acquisition, 19-2

- data acquisition filtering and timing, 19-2 to 19-3

- input channel and ranges, 19-1 to 19-2

- overview, 19-1

NI 435X devices, 18-1 to 18-4

- analog input, 18-1 to 18-2

- current source, 18-4

- data acquisition, 18-2 to 18-3

- data acquisition timing, 18-3

- digital I/O, 18-4

- overview, 18-1

- NI 5411 devices
 - characteristics (table), 17-1 to 17-2
 - feature settings, 17-6
 - overview, 17-1
 - waveform generation, 17-3 to 17-5
 - DDS mode, 17-3 to 17-4
 - examples (figure), 17-3
 - operational modes (table), 17-5
 - pattern generation, 17-4
 - pattern generation timing, 17-4
 - triggering, 17-5
- P**
- parallel mode for SCXI modules
 - analog input modules, 14-4 to 14-5
 - digital modules, 14-5 to 14-6
 - SCXI-1200, 14-5
- PC-4350. *See* NI 435X devices.
- PCI-445X and PCI-455X devices, 20-1 to 20-6
 - analog input channels, 20-1 to 20-3
 - data acquisition, 20-2 to 20-3
 - data acquisition timing, 20-3
 - counter/timer operation, 20-6
 - digital I/O, 20-5
 - hardware features (table), 20-1
 - PCI-4451 and PCI-4551 analog output channels, 20-4 to 20-5
 - waveform generation, 20-4 to 20-5
- PCI-671X and PXI-671X devices, 21-1 to 21-3
 - analog output, 21-1
 - counter/timer operation, 21-3
 - digital I/O, 21-2 to 21-3
 - PFI pins, 21-3
 - programmable frequency output operation, 21-3
 - waveform generation, 21-1
 - using onboard memory, 21-2
- PCI-6704 analog output board
 - digital I/O, 6-1
 - overview, 6-1
- PC-LPM-16 and PC-LPM-16/PnP. *See* LPM devices.
- PC-TIO-10 timing I/O board
 - counter/timer operation
 - Am9513-based operation, 7-1 to 7-4
 - counter/timers, 7-5
 - programmable frequency output operation, 7-4
 - digital I/O, 7-5
- PFI operation, Am9513-based devices, PC-TIO-10, 7-4
- PFI pins
 - E Series, 1-10
 - PCI-671X and PXI-671X devices, 21-3
- ports
 - 516 devices and DAQCard 500/700, 4-3
 - AT-AO-6/10 boards, 5-3
 - AT-MIO-16DE-10 and 6025E device ports (table), 1-10
 - DIO-24, AT-MIO-16DE-10, and 6025E, 9-1
 - groups of ports, 9-2
 - port numbers (table), 9-1
 - DIO-32F and DAQDIO 6533 (DIO-32HS), 10-1 to 10-2
 - DAQDIO 6533 (DIO-32HS) extra inputs and outputs (table), 10-3
 - DIO-32F extra inputs and outputs (table), 10-2
 - DIO-96 boards
 - configuration, 8-2
 - groups of ports, 8-3
 - port labels, numbers, and modes (table), 8-1 to 8-2
 - E Series, 1-9 to 1-10
 - Lab and 1200 devices groups of ports, 2-7
 - LPM devices, 3-3
 - NI 435X, 18-4
 - PCI-445X and PCI-455X, 20-5
 - PCI-671X and PXI-671X devices, 21-2 to 21-3

- VXI-AO-48XDC analog output board, 15-3
- VXI-DIO-128 digital I/O board, 15-2
- posttrigger mode
 - E Series, 1-4
 - Lab and 1200 devices, 2-3
 - PCI-445XI and PCI-455X, 20-2
- pretrigger mode
 - E Series, 1-4
 - Lab and 1200 devices, 2-3
 - PCI-445XI and PCI-455X, 20-2
- programmable frequency output operation
 - Am9513-based devices, PC-TIO-10 timing I/O board, 7-4
 - E Series, 1-10
 - PCI-671X and PXI-671X devices, 21-3
- PXI DAQ devices, 16-1 to 16-2
 - RTSI bus implementation, 16-1
 - signal conditioning, 16-2
- PXI-6704 analog output board
 - digital I/O, 6-1
 - overview, 6-1

R

- RTSI bus implementation
 - PXI DAQ devices, 16-1
 - VXI-DAQ devices, 15-1 to 15-2

S

- sample counter, Lab and 1200 devices, 2-4
- sample interval timer, E Series, 1-5
- sample interval timer timebase, E Series, 1-6
- SC-2040 track-and-hold accessory, 12-1
- SC-2042 RTD accessory, 12-2
- SC-2043-SG accessory, 12-2
- SC-2345 shielded carrier, 13-1 to 13-2
- scan counter, E Series, 1-5
- scan timer, E Series, 1-5
- scan timer timebase signal, E Series, 1-6

- scan-interval pulse signal, Lab and 1200 devices, 2-4
- SCC Series devices, 13-1 to 13-3
 - components, 13-2 to 13-3
 - configuration, 13-3
 - overview, 13-1
- SCC-A10 Voltage Attenuator module, 13-2
- SCC-C120 Current Input module, 13-2
- SCC-FT01 Feed Through/Breadboard module, 13-3
- SCC-TC01/02 Thermocouple Input modules, 13-2
- SCXI modules
 - for data acquisition front end
 - E Series, 1-5
 - Lab and 1200 devices, 2-3
 - installation and configuration, 14-2
 - multiplexed mode
 - analog input modules, 14-2 to 14-3
 - analog output modules, 14-4
 - digital and relay modules, 14-4
 - SCXI-1200, 14-3 to 14-4
 - operating modes, 14-2 to 14-6
 - overview, 14-1 to 14-2
 - parallel mode
 - analog input modules, 14-4 to 14-5
 - digital modules, 14-5 to 14-6
 - SCXI-1200, 14-5
 - support from specific devices
 - DIO-24 and DIO-96, 14-20 to 14-21
 - DIO-32F and DAQDIO 6533 (DIO-32HS), 14-21 to 14-22
 - MIO and AI multifunction device, 14-17 to 14-18
- SCXI-1100 module, 14-6 to 14-7
- SCXI-1101 module, 14-7
- SCXI-1102 module, 14-7 to 14-8
- SCXI-1102B and SCXI-1102C modules, 14-8
- SCXI-1120 and SCXI-1120D modules, 14-8 to 14-9
- SCXI-1121 module, 14-8 to 14-9

SCXI-1122 module, 14-9 to 14-10
 SCXI-1124 module, 14-10 to 14-11
 SCXI-1126 module, 14-11 to 14-12
 SCXI-1140 module, 14-12 to 14-13
 SCXI-1141 module, 14-13
 SCXI-1160 and SCXI-1161 modules, 14-14
 SCXI-1162 and SCXI-1162HV modules,
 14-14 to 14-15
 SCXI-1163 and SCXI-1163R modules,
 14-15 to 14-16
 SCXI-1200 module. *See also* Lab and 1200
 devices.
 calibration, 2-9 to 2-10
 data acquisition rates, 2-9
 multiplexed mode, 14-3 to 14-4
 overview, 14-16 to 14-17
 parallel (stand-alone) mode, 14-5
 signal conditioning
 PXI DAQ devices, 16-2
 VXI-DAQ devices, 15-3 to 15-4
 Signal Conditioning Components. *See* SCC
 Series devices.
 single-channel scanned data acquisition
 516 devices and DAQCard 500/700, 4-2
 E Series, 1-3
 Lab and 1200 devices, 2-2
 LPM devices, 3-1
 NI 435X, 18-2
 start scan signal, E Series, 1-6
 start trigger signal
 E Series, 1-4, 1-5
 Lab and 1200 devices, 2-4
 PCI-445XI and PCI-455X, 20-3
 stop trigger signal
 E Series, 1-4, 1-6
 Lab and 1200 devices, 2-5
 PCI-445XI and PCI-455X, 20-3

T

technical support, A-1 to A-2
 telephone and fax support numbers, A-2
 timebase clock signal
 516 devices and DAQCard 500/700, 4-3
 Lab and 1200 devices, 2-5
 LPM devices, 3-2
 timebases, Am9513-based devices, 7-1 to 7-2

V

VXI-AO-48XDC analog output board,
 15-2 to 15-3
 VXI-DAQ devices, 15-1 to 15-4
 overview, 15-1
 RTSI bus implementation, 15-1 to 15-2
 signal conditioning, 15-3 to 15-4
 VXI-DIO-128 digital I/O board, 15-2
 VXI-SC-1102 submodule, 15-4
 VXI-SC-1102B and VXI-SC-1102C
 submodules, 15-4
 VXI-SC-1150 submodule, 15-4

W

waveform generation
 AT-AO-6/10 boards, 5-1
 Lab and 1200 devices, 2-6
 MIO devices, 1-8
 NI 5411 devices, 17-3 to 17-5
 DDS mode, 17-3 to 17-4
 examples (figure), 17-3
 operational modes (table), 17-5
 pattern generation, 17-4
 pattern generation timing, 17-4
 triggering, 17-5
 PCI-445X and PCI-455X devices,
 20-4 to 20-5
 PCI-671X and PXI-671X devices, 21-1

using onboard memory
 AT-AO-6/10 boards, 5-1 to 5-2
 E Series, 1-8 to 1-9
 PCI-671X and PXI-671X
 devices, 21-2