

# DAQ

---

## 6023E/6024E/6025E User Manual

Multifunction I/O Boards for  
PCI, PXI, and CompactPCI Bus Computers

## **Worldwide Technical Support and Product Information**

<http://www.natinst.com>

### **National Instruments Corporate Headquarters**

11500 North Mopac Expressway Austin, Texas 78759-3504 USA Tel: 512 794 0100

### **Worldwide Offices**

Australia 03 9879 5166, Austria 0662 45 79 90 0, Belgium 02 757 00 20, Brazil 011 284 5011,  
Canada (Ontario) 905 694 0085, Canada (Québec) 514 694 8521, Denmark 45 76 26 00, Finland 09 725 725 11,  
France 0 1 48 14 24 24, Germany 089 741 31 30, Hong Kong 2645 3186, India 91805275406,  
Israel 03 6120092, Italy 02 413091, Japan 03 5472 2970, Korea 02 596 7456, Mexico (D.F.) 5 280 7625,  
Mexico (Monterrey) 8 357 7695, Netherlands 0348 433466, Norway 32 84 84 00, Singapore 2265886,  
Spain (Madrid) 91 640 0085, Spain (Barcelona) 93 582 0251, Sweden 08 587 895 00,  
Switzerland 056 200 51 51, Taiwan 02 2377 1200, United Kingdom 01635 523545

For further support information, see the *Technical Support Resources* appendix of this manual.

© Copyright 1999 National Instruments Corporation. All rights reserved.

# Important Information

---

## Warranty

The 6023E, 6024E, and 6025E boards are warranted against defects in materials and workmanship for a period of one year from the date of shipment, as evidenced by receipts or other documentation. National Instruments will, at its option, repair or replace equipment that proves to be defective during the warranty period. This warranty includes parts and labor.

The media on which you receive National Instruments software are warranted not to fail to execute programming instructions, due to defects in materials and workmanship, for a period of 90 days from date of shipment, as evidenced by receipts or other documentation. National Instruments will, at its option, repair or replace software media that do not execute programming instructions if National Instruments receives notice of such defects during the warranty period. National Instruments does not warrant that the operation of the software shall be uninterrupted or error free.

A Return Material Authorization (RMA) number must be obtained from the factory and clearly marked on the outside of the package before any equipment will be accepted for warranty work. National Instruments will pay the shipping costs of returning to the owner parts which are covered by warranty.

National Instruments believes that the information in this document is accurate. The document has been carefully reviewed for technical accuracy. In the event that technical or typographical errors exist, National Instruments reserves the right to make changes to subsequent editions of this document without prior notice to holders of this edition. The reader should consult National Instruments if errors are suspected. In no event shall National Instruments be liable for any damages arising out of or related to this document or the information contained in it.

EXCEPT AS SPECIFIED HEREIN, NATIONAL INSTRUMENTS MAKES NO WARRANTIES, EXPRESS OR IMPLIED, AND SPECIFICALLY DISCLAIMS ANY WARRANTY OF MERCHANTABILITY OR FITNESS FOR A PARTICULAR PURPOSE. CUSTOMER'S RIGHT TO RECOVER DAMAGES CAUSED BY FAULT OR NEGLIGENCE ON THE PART OF NATIONAL INSTRUMENTS SHALL BE LIMITED TO THE AMOUNT THEREFORE PAID BY THE CUSTOMER. NATIONAL INSTRUMENTS WILL NOT BE LIABLE FOR DAMAGES RESULTING FROM LOSS OF DATA, PROFITS, USE OF PRODUCTS, OR INCIDENTAL OR CONSEQUENTIAL DAMAGES, EVEN IF ADVISED OF THE POSSIBILITY THEREOF. This limitation of the liability of National Instruments will apply regardless of the form of action, whether in contract or tort, including negligence. Any action against National Instruments must be brought within one year after the cause of action accrues. National Instruments shall not be liable for any delay in performance due to causes beyond its reasonable control. The warranty provided herein does not cover damages, defects, malfunctions, or service failures caused by owner's failure to follow the National Instruments installation, operation, or maintenance instructions; owner's modification of the product; owner's abuse, misuse, or negligent acts; and power failure or surges, fire, flood, accident, actions of third parties, or other events outside reasonable control.

## Copyright

Under the copyright laws, this publication may not be reproduced or transmitted in any form, electronic or mechanical, including photocopying, recording, storing in an information retrieval system, or translating, in whole or in part, without the prior written consent of National Instruments Corporation.

## Trademarks

ComponentWorks™, CVI™, DAQ-STC™, LabVIEW™, Measure™, MITE™, natinst.com™, NI-DAQ™, RTSI™, SCXI™, and VirtualBench™ are trademarks of National Instruments Corporation.

Product and company names mentioned herein are trademarks or trade names of their respective companies.

## WARNING REGARDING MEDICAL AND CLINICAL USE OF NATIONAL INSTRUMENTS PRODUCTS

National Instruments products are not designed with components and testing intended to ensure a level of reliability suitable for use in treatment and diagnosis of humans. Applications of National Instruments products involving medical or clinical treatment can create a potential for accidental injury caused by product failure, or by errors on the part of the user or application designer. Any use or application of National Instruments products for or involving medical or clinical treatment must be performed by properly trained and qualified medical personnel, and all traditional medical safeguards, equipment, and procedures that are appropriate in the particular situation to prevent serious injury or death should always continue to be used when National Instruments products are being used. National Instruments products are NOT intended to be a substitute for any form of established process, procedure, or equipment used to monitor or safeguard human health and safety in medical or clinical treatment.

# Contents

---

## About This Manual

Organization of This Manual .....	xi
Conventions Used in This Manual .....	xii
National Instruments Documentation .....	xiii
Related Documentation.....	xiv
Customer Communication .....	xiv

## Chapter 1

### Introduction

Features of the 6023E, 6024E, and 6025E.....	1-1
Using PXI with CompactPCI.....	1-2
What You Need to Get Started .....	1-2
Unpacking .....	1-3
Software Programming Choices .....	1-3
National Instruments Application Software .....	1-4
NI-DAQ Driver Software .....	1-4
Register-Level Programming .....	1-6
Optional Equipment .....	1-6

## Chapter 2

### Installation and Configuration

Software Installation .....	2-1
Hardware Installation.....	2-1
Hardware Configuration .....	2-3

## Chapter 3

### Hardware Overview

Analog Input .....	3-2
Input Mode .....	3-2
Input Range .....	3-2
Dither .....	3-3
Multichannel Scanning Considerations .....	3-4
Analog Output.....	3-5
Analog Output Glitch .....	3-5
Digital I/O .....	3-6
Timing Signal Routing.....	3-6
Programmable Function Inputs .....	3-7

Board and RTSI Clocks .....	3-8
RTSI Triggers .....	3-8

## Chapter 4

### Signal Connections

I/O Connector .....	4-1
Analog Input Signal Overview .....	4-8
Types of Signal Sources .....	4-8
Floating Signal Sources .....	4-8
Ground-Referenced Signal Sources .....	4-9
Analog Input Modes .....	4-9
Analog Input Signal Connections .....	4-11
Differential Connection Considerations (DIFF Input Configuration) .....	4-13
Differential Connections for Ground-Referenced Signal Sources ...	4-14
Differential Connections for Nonreferenced or Floating	
Signal Sources .....	4-15
Single-Ended Connection Considerations .....	4-17
Single-Ended Connections for Floating Signal Sources	
(RSE Configuration) .....	4-18
Single-Ended Connections for Grounded Signal Sources	
(NRSE Configuration) .....	4-18
Common-Mode Signal Rejection Considerations .....	4-19
Analog Output Signal Connections .....	4-20
Digital I/O Signal Connections .....	4-21
All Boards .....	4-21
Programmable Peripheral Interface (PPI) .....	4-22
Port C Pin Assignments .....	4-23
Power-up State .....	4-24
Changing DIO Power-up State to Pulled Low .....	4-24
Timing Specifications .....	4-25
Mode 1 Input Timing .....	4-27
Mode 1 Output Timing .....	4-28
Mode 2 Bidirectional Timing .....	4-29
Power Connections .....	4-30
Timing Connections .....	4-30
Programmable Function Input Connections .....	4-31
DAQ Timing Connections .....	4-32
SCANCLK Signal .....	4-33
EXTSTROBE* Signal .....	4-33
TRIG1 Signal .....	4-34
TRIG2 Signal .....	4-35
STARTSCAN Signal .....	4-36

CONVERT* Signal.....	4-38
AIGATE Signal.....	4-39
SISOURCE Signal .....	4-40
Waveform Generation Timing Connections .....	4-40
WFTRIG Signal .....	4-40
UPDATE* Signal.....	4-41
UISOURCE Signal .....	4-42
General-Purpose Timing Signal Connections .....	4-43
GPCTR0_SOURCE Signal.....	4-43
GPCTR0_GATE Signal.....	4-44
GPCTR0_OUT Signal .....	4-45
GPCTR0_UP_DOWN Signal .....	4-45
GPCTR1_SOURCE Signal.....	4-45
GPCTR1_GATE Signal.....	4-46
GPCTR1_OUT Signal .....	4-47
GPCTR1_UP_DOWN Signal.....	4-47
FREQ_OUT Signal.....	4-49
Field Wiring Considerations.....	4-49

## **Chapter 5**

### **Calibration**

Loading Calibration Constants .....	5-1
Self-Calibration.....	5-2
External Calibration.....	5-2
Other Considerations .....	5-3

## **Appendix A**

### **Specifications**

## **Appendix B**

### **Custom Cabling and Optional Connectors**

## **Appendix C**

### **Common Questions**

## **Appendix D**

### **Customer Communication**

## Glossary

## Index

## Figures

Figure 1-1.	The Relationship between the Programming Environment, NI-DAQ, and Your Hardware.....	1-5
Figure 3-1.	6023E, 6024E, and 6025E Block Diagram.....	3-1
Figure 3-2.	Dither .....	3-4
Figure 3-3.	CONVERT* Signal Routing.....	3-7
Figure 3-4.	PCI RTSI Bus Signal Connection .....	3-9
Figure 3-5.	PXI RTSI Bus Signal Connection.....	3-10
Figure 4-1.	I/O Connector Pin Assignment for the 6023E/6024E.....	4-2
Figure 4-2.	I/O Connector Pin Assignment for the 6025E .....	4-3
Figure 4-3.	Programmable Gain Instrumentation Amplifier (PGIA) .....	4-10
Figure 4-4.	Summary of Analog Input Connections .....	4-12
Figure 4-5.	Differential Input Connections for Ground-Referenced Signals .....	4-14
Figure 4-6.	Differential Input Connections for Nonreferenced Signals .....	4-15
Figure 4-7.	Single-Ended Input Connections for Nonreferenced or Floating Signals .....	4-18
Figure 4-8.	Single-Ended Input Connections for Ground-Referenced Signals .....	4-19
Figure 4-9.	Analog Output Connections.....	4-20
Figure 4-10.	Digital I/O Connections .....	4-21
Figure 4-11.	Digital I/O Connections Block Diagram.....	4-22
Figure 4-12.	DIO Channel Configured for High DIO Power-up State with External Load.....	4-24
Figure 4-13.	Timing Specifications for Mode 1 Input Transfer .....	4-27
Figure 4-14.	Timing Specifications for Mode 1 Output Transfer .....	4-28
Figure 4-15.	Timing Specifications for Mode 2 Bidirectional Transfer.....	4-29
Figure 4-16.	Timing I/O Connections .....	4-31
Figure 4-17.	Typical Posttriggered Acquisition .....	4-32
Figure 4-18.	Typical Pretriggered Acquisition .....	4-33
Figure 4-19.	SCANCLK Signal Timing.....	4-33
Figure 4-20.	EXTSTROBE* Signal Timing .....	4-34
Figure 4-21.	TRIG1 Input Signal Timing.....	4-34
Figure 4-22.	TRIG1 Output Signal Timing .....	4-35
Figure 4-23.	TRIG2 Input Signal Timing.....	4-36
Figure 4-24.	TRIG2 Output Signal Timing .....	4-36
Figure 4-25.	STARTSCAN Input Signal Timing.....	4-37
Figure 4-26.	STARTSCAN Output Signal Timing .....	4-37

Figure 4-27.	CONVERT* Input Signal Timing.....	4-38
Figure 4-28.	CONVERT* Output Signal Timing .....	4-39
Figure 4-29.	SISOURCE Signal Timing.....	4-40
Figure 4-30.	WFTRIG Input Signal Timing .....	4-41
Figure 4-31.	WFTRIG Output Signal Timing.....	4-41
Figure 4-32.	UPDATE* Input Signal Timing .....	4-42
Figure 4-33.	UPDATE* Output Signal Timing .....	4-42
Figure 4-34.	UISOURCE Signal Timing .....	4-43
Figure 4-35.	GPCTR0_SOURCE Signal Timing .....	4-44
Figure 4-36.	GPCTR0_GATE Signal Timing in Edge-Detection Mode.....	4-44
Figure 4-37.	GPCTR0_OUT Signal Timing .....	4-45
Figure 4-38.	GPCTR1_SOURCE Signal Timing .....	4-46
Figure 4-39.	GPCTR1_GATE Signal Timing in Edge-Detection Mode.....	4-47
Figure 4-40.	GPCTR1_OUT Signal Timing .....	4-47
Figure 4-41.	GPCTR Timing Summary.....	4-48
Figure B-1.	68-Pin E Series Connector Pin Assignments .....	B-3
Figure B-2.	68-Pin Extended Digital Input Connector Pin Assignments .....	B-4
Figure B-3.	50-Pin E Series Connector Pin Assignments .....	B-5
Figure B-4.	50-Pin Extended Digital Input Connector Pin Assignments .....	B-6

## Tables

Table 3-1.	Available Input Configurations .....	3-2
Table 3-2.	Measurement Precision .....	3-3
Table 3-3.	Pins Used by PXI E Series Board .....	3-10
Table 4-1.	I/O Connector Signal Descriptions .....	4-4
Table 4-2.	I/O Signal Summary .....	4-7
Table 4-3.	Port C Signal Assignments .....	4-23
Table 4-4.	Signal Names Used in Timing Diagrams .....	4-25



# About This Manual

---

The 6023, 6024, and 6025 E Series boards are high-performance multifunction analog, digital, and timing I/O boards for PCI, PXI, and CompactPCI bus computers. Supported functions include analog input, analog output, digital I/O, and timing I/O.

This manual describes the electrical and mechanical aspects of the PCI-6023E, PCI-6024E, PCI-6025E, and PXI-6025E boards from the E Series product line and contains information concerning their operation and programming.

## Organization of This Manual

---

The *6023E/6024E/6025E User Manual* is organized as follows:



- Chapter 1, *Introduction*, describes the boards, lists what you need to get started, gives unpacking instructions, and describes the optional software and equipment.
- Chapter 2, *Installation and Configuration*, explains how to install and configure your board.
- Chapter 3, *Hardware Overview*, presents an overview of the hardware functions on your board.
- Chapter 4, *Signal Connections*, describes how to make input and output signal connections to your board via the I/O connector.
- Chapter 5, *Calibration*, discusses the calibration procedures for your board.
- Appendix A, *Specifications*, lists the specifications of each board.
- Appendix B, *Custom Cabling and Optional Connectors*, describes the various cabling and connector options.
- Appendix C, *Common Questions*, contains a list of commonly asked questions and their answers relating to usage and special features of your board.
- Appendix D, *Customer Communication*, contains forms you can use to request help from National Instruments or to comment on our products and manuals.
- The *Glossary* contains an alphabetical list and description of terms used in this manual, including abbreviations, acronyms, metric prefixes, mnemonics, and symbols.

- The *Index* contains an alphabetical list of key terms and topics in this manual, including the page where you can find each one.

## Conventions Used in This Manual

---

The following conventions are used in this manual:

<>	Angle brackets containing numbers separated by an ellipsis represent a range of values associated with a bit or signal name—for example, DBIO<3..0>.
◆	The ◆ symbol indicates that the text following it applies only to a specific product, a specific operating system, or a specific software version.
	This icon to the left of bold italicized text denotes a note, which alerts you to important information.
	This icon to the left of bold italicized text denotes a caution, which advises you of precautions to take to avoid injury, data loss, or a system crash.
<b>bold</b>	Bold text denotes the names of menus, menu items, parameters, dialog boxes, dialog box buttons or options, icons, windows, Windows 95 tabs, or LEDs.
<b><i>bold italic</i></b>	Bold italic text denotes an activity objective, note, caution, or warning.
<i>italic</i>	Italic text denotes variables, emphasis, a cross reference, or an introduction to a key concept. This font also denotes text from which you supply the appropriate word or value, as in Windows 3.x.
monospace	Text in this font denotes text or characters that you should literally enter from the keyboard, sections of code, programming examples, and syntax examples. This font is also used for the proper names of disk drives, paths, directories, programs, subprograms, subroutines, device names, functions, operations, variables, filenames and extensions, and for statements and comments taken from programs.
CompactPCI	Refers to the core specification defined by the PCI Industrial Computer Manufacturer's Group (PICMG)
NI-DAQ	Refers to the NI-DAQ driver software for PC compatible computers unless otherwise noted.
PC	Refers to all PC AT series computers with PCI or PXI bus unless otherwise noted.

## PXI

Stands for PCI eXtensions for Instrumentation. PXI is an open specification that builds off the CompactPCI specification by adding instrumentation-specific features.

## National Instruments Documentation

---

The *6023E/6024E/6025E User Manual* is one piece of the documentation set for your DAQ system. You could have any of several types of manuals depending on the hardware and software in your system. Use the manuals you have as follows:

- *Getting Started with SCXI*—If you are using SCXI, this is the first manual you should read. It gives an overview of the SCXI system and contains the most commonly needed information for the modules, chassis, and software.
- Your SCXI hardware user manuals—If you are using SCXI, read these manuals next for detailed information about signal connections and module configuration. They also explain in greater detail how the module works and contain application hints.
- *SCXI Chassis Manual*—If you are using SCXI, read this manual for maintenance information on the chassis and installation instructions.
- Your DAQ hardware documentation—This documentation has detailed information about the DAQ hardware that plugs into or is connected to your computer. Use this documentation for hardware installation and configuration instructions, specification information about your DAQ hardware, and application hints.
- Software documentation—You may have both application software and NI-DAQ software documentation. National Instruments application software includes ComponentWorks, LabVIEW, LabWindows/CVI, Measure, and VirtualBench. After you set up your hardware system, use either your application software documentation or the NI-DAQ documentation to help you write your application. If you have a large, complicated system, it is worthwhile to look through the software documentation before you configure your hardware.
- Accessory installation guides or manuals—If you are using accessory products, read the terminal block and cable assembly installation guides. They explain how to physically connect the relevant pieces of the system. Consult these guides when you are making your connections.

## Related Documentation

---

The following documents contain information you may find helpful:

- *DAQ-STC Technical Reference Manual*
- National Instruments Application Note 025, *Field Wiring and Noise Considerations for Analog Signals*
- *PCI Local Bus Specification Revision 2.1*
- *PICMG CompactPCI 2.0 Revision 2.1*
- *PXI Bus Specification Revision 1.0*

The following National Instruments manual contains detailed information for the register-level programmer:

- *PCI E Series Register-Level Programmer Manual*

This manual is available from National Instruments by request. You should not need the register-level programmer manual if you are using National Instruments driver or application software. Using NI-DAQ, ComponentWorks, LabVIEW, LabWindows/CVI, Measure, or VirtualBench software is easier than the low-level programming described in the register-level programmer manual.

## Customer Communication

---

National Instruments wants to receive your comments on our products and manuals. We are interested in the applications you develop with our products, and we want to help if you have problems with them. To make it easy for you to contact us, this manual contains comment and configuration forms for you to complete. These forms are in Appendix D, [Customer Communication](#), at the end of this manual.

---

# Introduction

This chapter describes the 6023E, 6024E, and 6025E boards, lists what you need to get started, gives unpacking instructions, and describes the optional software and equipment.

## Features of the 6023E, 6024E, and 6025E

---

Thank you for buying a National Instruments 6023E, 6024E, or 6025E board. The 6025E features 16 channels (eight differential) of analog input, two channels of analog output, a 100-pin connector, and 32 lines of digital I/O. The 6024E features 16 channels of analog input, two channels of analog output, a 68-pin connector and eight lines of digital I/O. The 6023E is identical to the 6024E, except that it does not have analog output channels.

These boards use the National Instruments DAQ-STC system timing controller for time-related functions. The DAQ-STC consists of three timing groups that control analog input, analog output, and general-purpose counter/timer functions. These groups include a total of seven 24-bit and three 16-bit counters and a maximum timing resolution of 50 ns. The DAQ-STC makes possible such applications as buffered pulse generation, equivalent time sampling, and seamless changing of the sampling rate.

With other DAQ boards, you cannot easily synchronize several measurement functions to a common trigger or timing event. These boards have the Real-Time System Integration (RTSI) bus to solve this problem. In a PCI system, the RTSI bus consists of the National Instruments RTSI bus interface and a ribbon cable to route timing and trigger signals between several functions on as many as five DAQ boards in your computer. In a PXI system, the RTSI bus consists of the National Instruments RTSI bus interface and the PXI trigger signals on the PXI backplane to route timing and trigger signals between several functions on as many as seven DAQ boards in your system.

These boards can interface to an SCXI system—the instrumentation front end for plug-in DAQ boards—so that you can acquire analog signals from thermocouples, RTDs, strain gauges, voltage sources, and current sources. You can also acquire or generate digital signals for communication and control.

## Using PXI with CompactPCI

---

Using PXI compatible products with standard CompactPCI products is an important feature provided by *PXI Specification, Revision 1.0*. If you use a PXI compatible plug-in card in a standard CompactPCI chassis, you will be unable to use PXI-specific functions, but you can still use the basic plug-in card functions. For example, the RTSI bus on your PXI E Series board is available in a PXI chassis, but not in a CompactPCI chassis.

The CompactPCI specification permits vendors to develop sub-buses that coexist with the basic PCI interface on the CompactPCI bus. Compatible operation is not guaranteed between CompactPCI boards with different sub-buses nor between CompactPCI boards with sub-buses and PXI. The standard implementation for CompactPCI does not include these sub-buses. Your PXI E Series board will work in any standard CompactPCI chassis adhering to *PICMG CompactPCI 2.0 R2.1* core specification.

PXI specific features are implemented on the J2 connector of the CompactPCI bus. Table 3-3 lists the J2 pins used by your PXI E Series board. Your PXI board is compatible with any Compact PCI chassis with a sub-bus that does not drive these lines. Even if the sub-bus is capable of driving these lines, the PXI board is still compatible as long as those pins on the sub-bus are disabled by default and not ever enabled. Damage may result if these lines are driven by the sub-bus.

## What You Need to Get Started

---

To set up and use your board, you will need the following:

- One of the following boards:
  - PCI-6023E
  - PCI-6024E
  - PCI-6025E
  - PXI-6025E
- [6023E/6024E/6025E User Manual](#)

- ❑ One of the following software packages and documentation:
  - ComponentWorks
  - LabVIEW for Windows
  - LabWindows/CVI for Windows
  - Measure
  - NI-DAQ for PC Compatibles
  - VirtualBench
- ❑ Your computer equipped with one of the following:
  - PCI bus for a PCI board
  - PXI or CompactPCI chassis and controller for a PXI board

**Note**

*Read Chapter 2, [Installation and Configuration](#), before installing your board. Always install your software before installing your board.*

## Unpacking

---

Your board is shipped in an antistatic package to prevent electrostatic damage to the board. Electrostatic discharge can damage several components on the board. To avoid such damage in handling the board, take the following precautions:

- Ground yourself via a grounding strap or by holding a grounded object.
- Touch the antistatic package to a metal part of your computer chassis before removing the board from the package.
- Remove the board from the package and inspect the board for loose components or any other sign of damage. Notify National Instruments if the board appears damaged in any way. *Do not* install a damaged board into your computer.
- *Never* touch the exposed pins of connectors.

## Software Programming Choices

---

You have several options to choose from when programming your National Instruments DAQ and SCXI hardware. You can use National Instruments application software, NI-DAQ, or register-level programming.

## National Instruments Application Software

ComponentWorks contains tools for data acquisition and instrument control built on NI-DAQ driver software. ComponentWorks provides a higher-level programming interface for building virtual instruments through standard OLE controls and DLLs. With ComponentWorks, you can use all of the configuration tools, resource management utilities, and interactive control utilities included with NI-DAQ.

LabVIEW features interactive graphics, a state-of-the-art user interface, and a powerful graphical programming language. The LabVIEW Data Acquisition VI Library, a series of VIs for using LabVIEW with National Instruments DAQ hardware, is included with LabVIEW. The LabVIEW Data Acquisition VI Library is functionally equivalent to NI-DAQ software.

LabWindows/CVI features interactive graphics, state-of-the-art user interface, and uses the ANSI standard C programming language. The LabWindows/CVI Data Acquisition Library, a series of functions for using LabWindows/CVI with National Instruments DAQ hardware, is included with the NI-DAQ software kit. The LabWindows/CVI Data Acquisition Library is functionally equivalent to the NI-DAQ software.

VirtualBench features virtual instruments that combine DAQ products, software, and your computer to create a stand-alone instrument with the added benefit of the processing, display, and storage capabilities of your computer. VirtualBench instruments load and save waveform data to disk in the same forms that can be used in popular spreadsheet programs and word processors.

Using ComponentWorks, LabVIEW, LabWindows/CVI, or VirtualBench software will greatly reduce the development time for your data acquisition and control application.

## NI-DAQ Driver Software

The NI-DAQ driver software is included at no charge with all National Instruments DAQ hardware. NI-DAQ is not packaged with SCXI or accessory products, except for the SCXI-1200. NI-DAQ has an extensive library of functions that you can call from your application programming environment. These functions include routines for analog input (A/D conversion), buffered data acquisition (high-speed A/D conversion), analog output (D/A conversion), waveform generation (timed D/A conversion), digital I/O, counter/timer operations, SCXI, RTSI, self-calibration, messaging, and acquiring data to extended memory.



NI-DAQ has both high-level DAQ I/O functions for maximum ease of use and low-level DAQ I/O functions for maximum flexibility and performance. Examples of high-level functions are streaming data to disk or acquiring a certain number of data points. An example of a low-level function is writing directly to registers on the DAQ device. NI-DAQ does not sacrifice the performance of National Instruments DAQ devices because it lets multiple devices operate at their peak.

NI-DAQ also internally addresses many of the complex issues between the computer and the DAQ hardware such as programming interrupts and DMA controllers. NI-DAQ maintains a consistent software interface among its different versions so that you can change platforms with minimal modifications to your code. Whether you are using conventional programming languages or National Instruments application software, your application uses the NI-DAQ driver software, as illustrated in Figure 1-1.

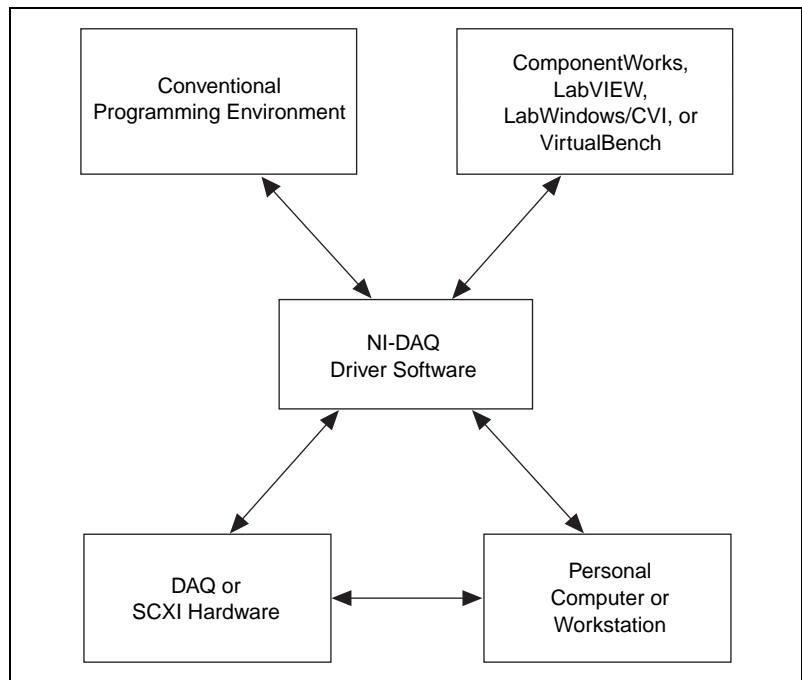

**Figure 1-1.** The Relationship between the Programming Environment, NI-DAQ, and Your Hardware

## Register-Level Programming

The final option for programming any National Instruments DAQ hardware is to write register-level software. Writing register-level programming software can be very time-consuming and inefficient, and is not recommended for most users.

Even if you are an experienced register-level programmer, using NI-DAQ or application software to program your National Instruments DAQ hardware is easier than, and as flexible as, register-level programming, and can save weeks of development time.

## Optional Equipment

---

National Instruments offers a variety of products to use with your board, including cables, connector blocks, and other accessories, as follows:

- Cables and cable assemblies, shielded and ribbon
- Connector blocks, shielded and unshielded screw terminals
- RTSI bus cables
- SCXI modules and accessories for isolating, amplifying, exciting, and multiplexing signals for relays and analog output. With SCXI you can condition and acquire up to 3,072 channels.
- Low channel count signal conditioning modules, boards, and accessories, including conditioning for strain gauges and RTDs, simultaneous sample and hold, and relays

For more information about these products, refer to the National Instruments catalogue or web site or call the office nearest you.

---

# Installation and Configuration

This chapter explains how to install and configure your 6023E, 6024E, or 6025E board.

## Software Installation

---

*Install your software before you install your board.* Refer to the appropriate release notes indicated below for specific instructions on the software installation sequence.

If you are using NI-DAQ, refer to your NI-DAQ release notes. Find the installation section for your operating system and follow the instructions given there.

If you are using LabVIEW, LabWindows/CVI, or other National Instruments application software packages, refer to the appropriate release notes. After you have installed your application software, refer to your NI-DAQ release notes and follow the instructions given there for your operating system and application software package.

If you are a register-level programmer, refer to the *PCI E Series Register-Level Programmer Manual* and the *DAQ-STC Technical Reference Manual* for software configuration information.

## Hardware Installation

---



**Note**

*Install your software before you install your board.*

After installing your software, you are ready to install your hardware. Your board will fit in any 5 V expansion slot in your computer. However, to achieve best noise performance, leave as much room as possible between your board and other devices. The following are general installation instructions. Consult your computer user manual or technical reference manual for specific instructions and warnings.

◆ PCI Board Installation

1. Write down your board's serial number in the [6023E/6024E/6025E Hardware and Software Configuration Form](#) in Appendix D, [Customer Communication](#), of this manual.
2. Turn off and unplug your computer.
3. Remove the top cover of your computer.
4. Remove the expansion slot cover on the back panel of the computer.
5. Touch any metal part of your computer chassis to discharge any static electricity that might be on your clothes or body.
6. Insert the board into a 5 V PCI slot. Gently rock the board to ease it into place. It may be a tight fit, but *do not force* the board into place.
7. Screw the mounting bracket of the board to the back panel rail of the computer.
8. Visually verify the installation.
9. Replace the top cover of your computer.
10. Plug in and turn on your computer.

◆ PXI Board Installation

1. Write down your board's serial number in the [6023E/6024E/6025E Hardware and Software Configuration Form](#) in Appendix D, [Customer Communication](#), of this manual.
2. Turn off and unplug your computer.
3. Choose an unused PXI slot in your system. For maximum performance, the board has an onboard DMA controller that can only be used if the board is installed in a slot that supports bus arbitration, or bus master cards. National Instruments recommends installing the board in such a slot. The PXI specification requires all slots to support bus master cards, but the CompactPCI specification does not. If you install in a CompactPCI non-master slot, you must disable the board's onboard DMA controller using software.
4. Remove the filler panel for the slot you have chosen.
5. Touch any metal part of your computer chassis to discharge any static electricity that might be on your clothes or body.
6. Insert the board into a 5 V PXI slot. Use the injector/ejector handle to fully insert the board into the chassis.
7. Screw the front panel of the board to the front panel mounting rail of the system.

8. Visually verify the installation.
9. Plug in and turn on your computer.

The board is installed. You are now ready to configure your hardware and software.

## Hardware Configuration

---

Due to the National Instruments standard architecture for data acquisition and standard bus specifications, these boards are completely software-configurable. You must perform two types of configuration on the boards—bus-related and data acquisition-related configuration.

The PCI boards are fully compatible with the industry-standard *PCI Local Bus Specification Revision 2.1*. The PXI board is fully compatible with the *PXI Specification Revision 1.0*. These specifications let your computer automatically set the board base memory address and interrupt channel with no user interaction.

You can modify data acquisition-related configuration settings, such as analog input range and mode, through application-level software. Refer to Chapter 3, *Hardware Overview*, for more information about the various settings available for your board. These settings are changed and configured through software after you install your board. Refer to your software documentation for configuration instructions.

## Hardware Overview

This chapter presents an overview of the hardware functions on your board.

Figure 3-1 shows a block diagram for the 6023E, 6024E, and 6025E.

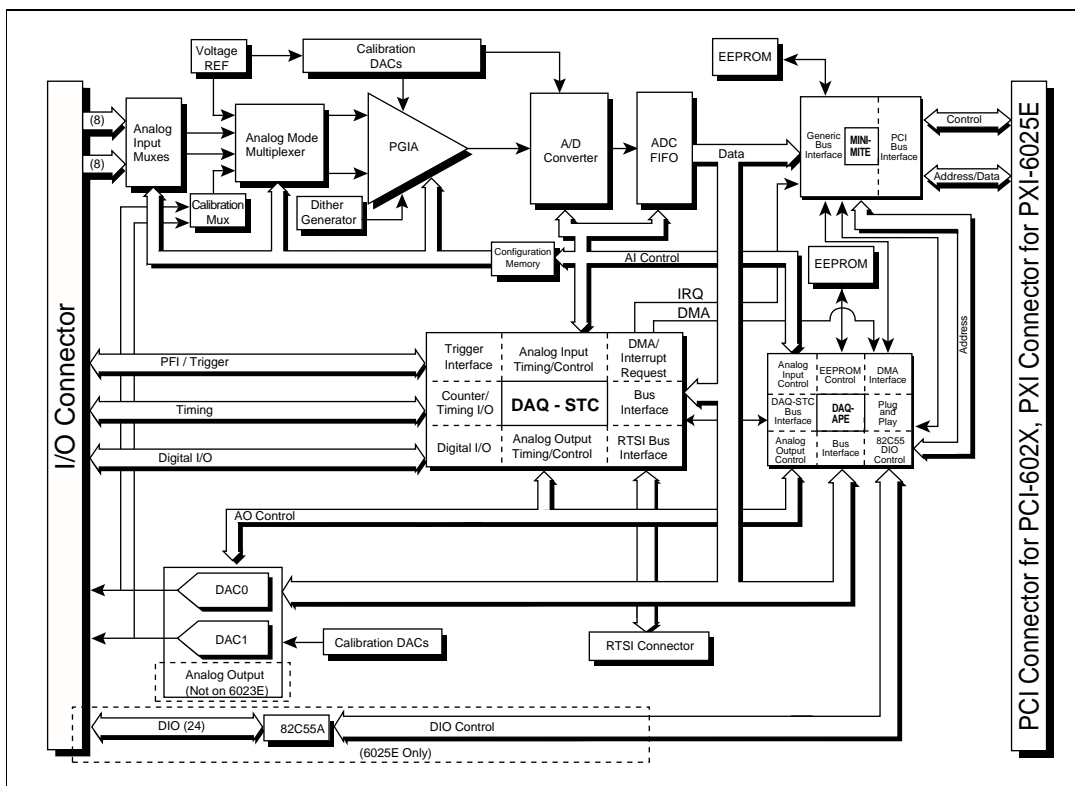

**Figure 3-1.** 6023E, 6024E, and 6025E Block Diagram

# Analog Input

The analog input section of each board is software configurable. The following sections describe in detail each of the analog input settings.

## Input Mode

The boards have three different input modes—nonreferenced single-ended (NRSE) input, referenced single-ended (RSE) input, and differential (DIFF) input. The single-ended input configurations provide up to 16 channels. The DIFF input configuration provides up to eight channels. Input modes are programmed on a per channel basis for multimode scanning. For example, you can configure the circuitry to scan 12 channels—four differentially-configured channels and eight single-ended channels. Table 3-1 describes the three input configurations.

**Table 3-1.** Available Input Configurations

Configuration	Description
DIFF	A channel configured in DIFF mode uses two analog input lines. One line connects to the positive input of the board's programmable gain instrumentation amplifier (PGIA), and the other connects to the negative input of the PGIA.
RSE	A channel configured in RSE mode uses one analog input line, which connects to the positive input of the PGIA. The negative input of the PGIA is internally tied to analog input ground (AIGND).
NRSE	A channel configured in NRSE mode uses one analog input line, which connects to the positive input of the PGIA. The negative input of the PGIA connects to analog input sense (AISENSE).

For diagrams showing the signal paths of the three configurations, refer to the [Analog Input Signal Overview](#) section in Chapter 4, [Signal Connections](#).

## Input Range

The boards have a bipolar input range that changes with the programmed gain. Each channel may be programmed with a unique gain of 0.5, 1.0, 10, or 100 to maximize the 12-bit analog-to-digital converter (ADC)

resolution. With the proper gain setting, you can use the full resolution of the ADC to measure the input signal. Table 3-2 shows the input range and precision according to the gain used.

**Table 3-2.** Measurement Precision

Gain	Input Range	Precision *
0.5	-10 to +10 V	4.88 mV
1.0	-5 to +5 V	2.44 mV
10.0	-500 to +500 mV	244.14 $\mu$ V
100.0	-50 to +50 mV	24.41 $\mu$ V

\*The value of 1 LSB of the 12-bit ADC; that is, the voltage increment corresponding to a change of one count in the ADC 12-bit count.

**Note:** See Appendix A, *Specifications*, for absolute maximum ratings.

## Dither

When you enable dither, you add approximately 0.5 LSB<sub>rms</sub> of white Gaussian noise to the signal to be converted by the ADC. This addition is useful for applications involving averaging to increase the resolution of your board, as in calibration or spectral analysis. In such applications, noise modulation is decreased and differential linearity is improved by the addition of the dither. When taking DC measurements, such as when checking the board calibration, you should enable dither and average about 1,000 points to take a single reading. This process removes the effects of quantization and reduces measurement noise, resulting in improved resolution. For high-speed applications not involving averaging or spectral analysis, you may want to disable the dither to reduce noise. Your software enables and disables the dither circuitry.

Figure 3-2 illustrates the effect of dither on signal acquisition. Figure 3-2a shows a small ( $\pm 4$  LSB) sine wave acquired with dither off. The ADC quantization is clearly visible. Figure 3-2b shows what happens when 50 such acquisitions are averaged together; quantization is still plainly visible. In Figure 3-2c, the sine wave is acquired with dither on. There is a considerable amount of visible noise, but averaging about 50 such acquisitions, as shown in Figure 3-2d, eliminates both the added noise and the effects of quantization. Dither has the effect of forcing quantization noise to become a zero-mean random variable rather than a deterministic function of the input signal.



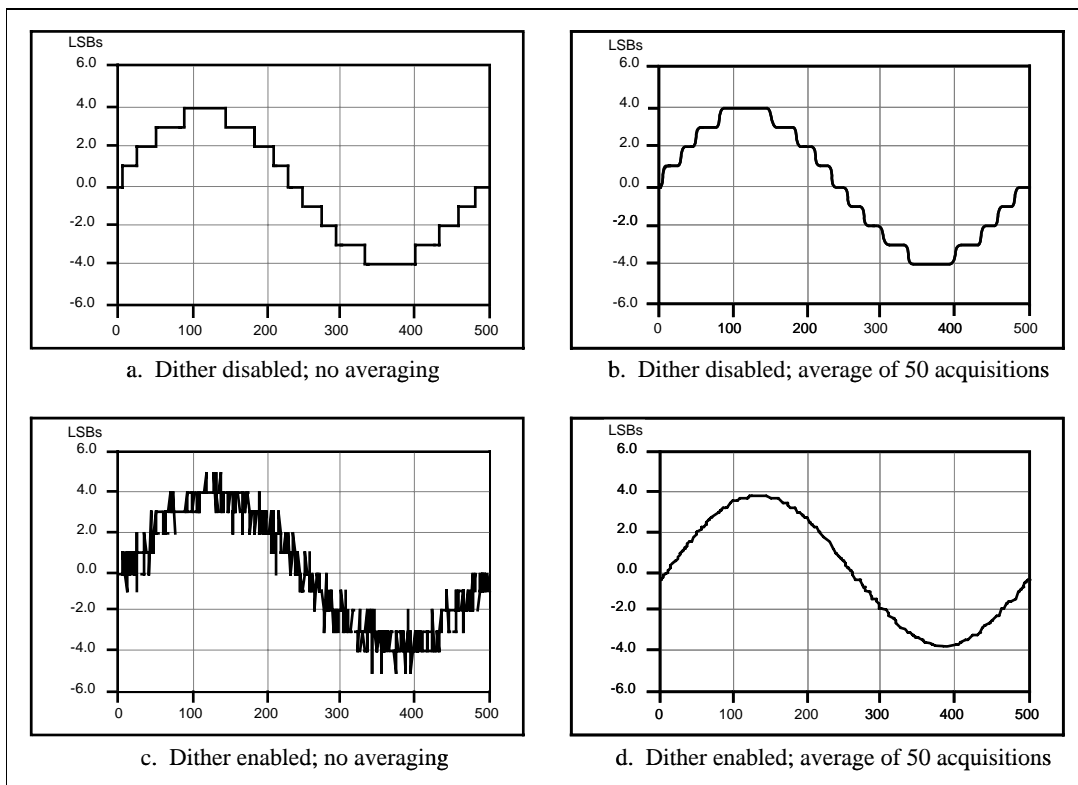

Figure 3-2. Dither

## Multichannel Scanning Considerations

The boards can scan multiple channels at the same maximum rate as their single-channel rate; however, pay careful attention to the settling times for each of the boards. No extra settling time is necessary between channels as long as the gain is constant and source impedances are low. Refer to Appendix A, *Specifications*, for a complete listing of settling times for each of the boards.

When scanning among channels at various gains, the settling times may increase. When the PGIA switches to a higher gain, the signal on the previous channel may be well outside the new, smaller range. For instance, suppose a 4 V signal is connected to channel 0 and a 1 mV signal is connected to channel 1, and suppose the PGIA is programmed to apply a gain of one to channel 0 and a gain of 100 to channel 1. When the multiplexer switches to channel 1 and the PGIA switches to a gain of 100, the new full-scale range is  $\pm 50$  mV.

The approximately 4 V step from 4 V to 1 mV is 4,000% of the new full-scale range. It may take as long as 100  $\mu$ s for the circuitry to settle to 1 LSB after such a large transition. In general, this extra settling time is not needed when the PGIA is switching to a lower gain.

Settling times can also increase when scanning high-impedance signals due to a phenomenon called *charge injection*, where the analog input multiplexer injects a small amount of charge into each signal source when that source is selected. If the impedance of the source is not low enough, the effect of the charge—a voltage error—will not have decayed by the time the ADC samples the signal. For this reason, keep source impedances under 1 k $\Omega$  to perform high-speed scanning.

Due to the previously described limitations of settling times resulting from these conditions, multiple-channel scanning is not recommended unless sampling rates are low enough or it is necessary to sample several signals as nearly simultaneously as possible. The data is much more accurate and channel-to-channel independent if you acquire data from each channel independently (for example, 100 points from channel 0, then 100 points from channel 1, then 100 points from channel 2, and so on).

## Analog Output

---

- ◆ 6025E and 6024E only

These boards supply two channels of analog output voltage at the I/O connector. The bipolar range is fixed at  $\pm 10$  V. Data written to the digital-to-analog converter (DAC) will be interpreted as two's complement format.

### Analog Output Glitch

In normal operation, a DAC output will glitch whenever it is updated with a new value. The glitch energy differs from code to code and appears as distortion in the frequency spectrum.

## Digital I/O

---

The boards contain eight lines of digital I/O (DIO<0..7>) for general-purpose use. You can individually software-configure each line for either input or output. At system startup and reset, the digital I/O ports are all high impedance.

The hardware up/down control for general-purpose counters 0 and 1 are connected onboard to DIO6 and DIO7, respectively. Thus, you can use DIO6 and DIO7 to control the general-purpose counters. The up/down control signals are input only and do not affect the operation of the DIO lines.

- ◆ 6025E only

The 6025E board uses an 82C55A Programmable Peripheral Interface to provide an additional 24 lines of digital I/O that represent three 8-bit ports: PA, PB, PC. Each port can be programmed as an input or output port. The 82C55A has three modes of operation: simple I/O (mode 0), strobed I/O (mode 1), and bidirectional I/O (mode 2). In modes 1 and 2, the three ports are divided into two groups: group A and group B. Each group has eight data bits, plus control and status bits from Port C (PC). Modes 1 and 2 use handshaking signals from the computer to synchronize data transfers. Refer to Chapter 4, *Signal Connections*, for more detailed information.

## Timing Signal Routing

---

The DAQ-STC chip provides a flexible interface for connecting timing signals to other boards or external circuitry. Your board uses the RTSI bus to interconnect timing signals between boards, and the Programmable Function Input (PFI) pins on the I/O connector to connect the board to external circuitry. These connections are designed to enable the board to both control and be controlled by other boards and circuits.

There are a total of 13 timing signals internal to the DAQ-STC that can be controlled by an external source. These timing signals can also be controlled by signals generated internally to the DAQ-STC, and these selections are fully software-configurable. Figure 3-3 shows an example of the signal routing multiplexer controlling the CONVERT\* signal.

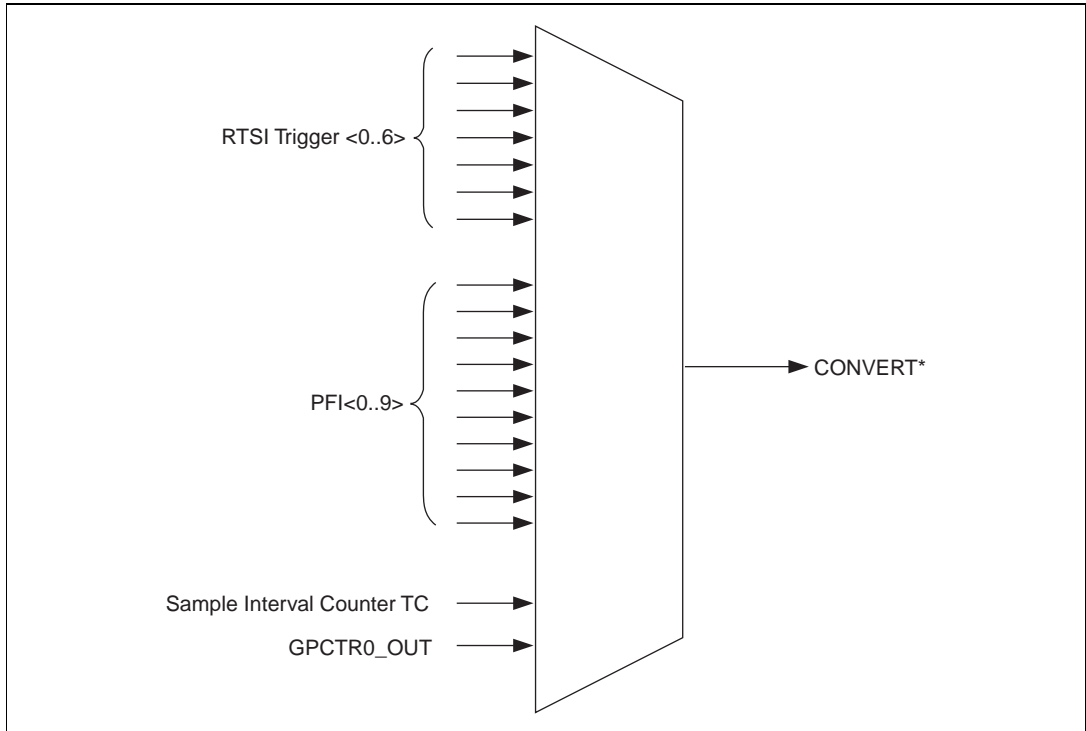

**Figure 3-3.** CONVERT\* Signal Routing

This figure shows that CONVERT\* can be generated from a number of sources, including the external signals RTSI<0..6> and PFI<0..9> and the internal signals Sample Interval Counter TC and GPCTR0\_OUT.

Many of these timing signals are also available as outputs on the RTSI pins, as indicated in the [RTSI Triggers](#) section in this chapter, and on the PFI pins, as indicated in Chapter 4, [Signal Connections](#).

## Programmable Function Inputs

Ten PFI pins are available on the board connector as PFI<0..9> and are connected to the board's internal signal routing multiplexer for each timing signal. Software can select any one of the PFI pins as the external source for a given timing signal. It is important to note that any of the PFI pins can be used as an input by any of the timing signals and that multiple timing signals can use the same PFI simultaneously. This flexible routing scheme reduces the need to change physical connections to the I/O connector for different applications.

You can also individually enable each of the PFI pins to output a *specific* internal timing signal. For example, if you need the UPDATE\* signal as an output on the I/O connector, software can turn on the output driver for the PFI5/UPDATE\* pin.

## Board and RTSI Clocks

Many board functions require a frequency timebase to generate the necessary timing signals for controlling A/D conversions, DAC updates, or general-purpose signals at the I/O connector.

These boards can use either its internal 20 MHz timebase or a timebase received over the RTSI bus. In addition, if you configure the board to use the internal timebase, you can also program the board to drive its internal timebase over the RTSI bus to another board that is programmed to receive this timebase signal. This clock source, whether local or from the RTSI bus, is used directly by the board as the primary frequency source. The default configuration at startup is to use the internal timebase without driving the RTSI bus timebase signal. This timebase is software selectable.

### ◆ PXI-6025E

The RTSI clock connects to other boards through the PXI trigger bus on the PXI backplane. The RTSI clock signal uses the PXI trigger <7> line for this connection.

## RTSI Triggers

The seven RTSI trigger lines on the RTSI bus provide a very flexible interconnection scheme for any board sharing the RTSI bus. These bidirectional lines can drive any of eight timing signals onto the RTSI bus and can receive any of these timing signals. This signal connection scheme is shown in Figure 3-4 for PCI boards and Figure 3-5 for PXI boards.

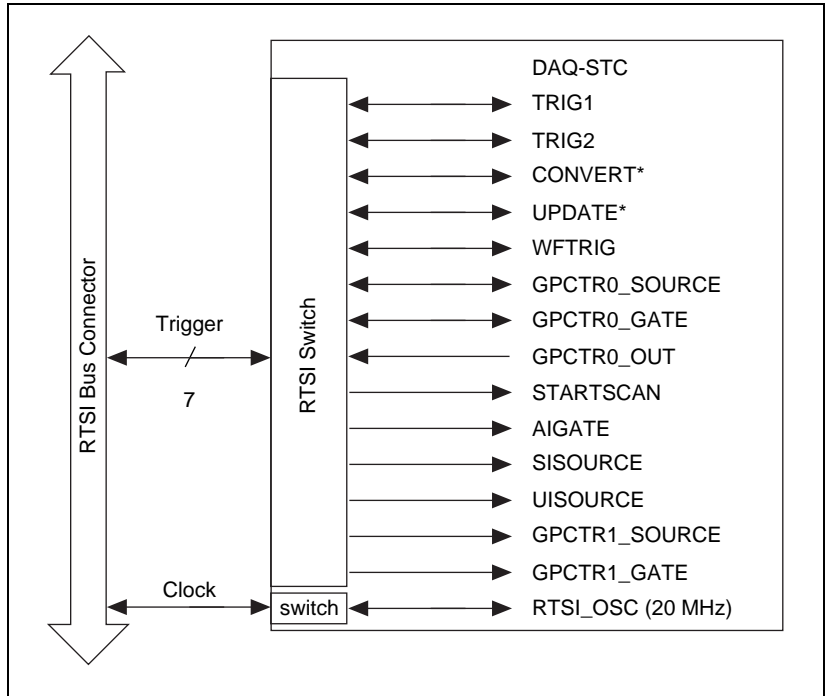

**Figure 3-4.** PCI RTSI Bus Signal Connection

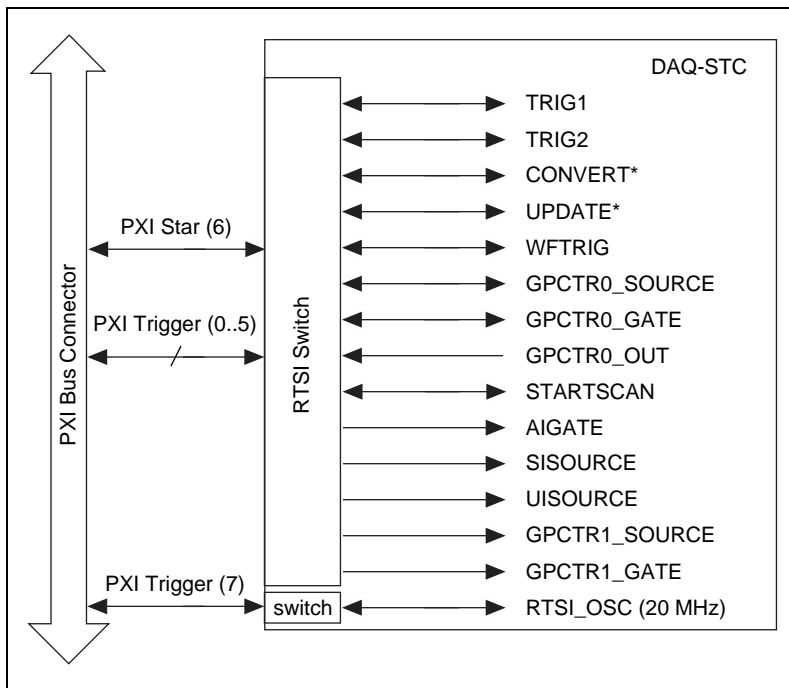

**Figure 3-5.** PXI RTSI Bus Signal Connection

Table 3-3 lists the name and number of pins used by the PXI-6025E.

**Table 3-3.** Pins Used by PXI E Series Board

PXI E Series Signal	PXI Pin Name	PXI J2 Pin Number
RTSI<0.5>	PXI Trigger<0.5>	B16, A16, A17, A18, B18, C18
RTSI 6	PXI Star	D17
RTSI Clock	PXI Trigger 7	E16
Reserved	LBL<0..3>	C20, E20, A19, C19
Reserved	LBR<0..12>	A21, C21, D21, E21, A20, B20, E15, A3, C3, D3, E3, A2, B2

Refer to the *Timing Connections* section of Chapter 4, *Signal Connections*, for a description of the signals shown in Figures 3-4 and 3-5.

---

# Signal Connections

This chapter describes how to make input and output signal connections to your board via the I/O connector.

The I/O connector for the 6023 and 6024E has 68 pins that you can connect to 68-pin accessories with the SH6868 shielded cable or the R6868 ribbon cable. You can connect your board to 50-pin signal accessories with the SH6850 shielded cable or R6850 ribbon cable.

The I/O connector for the 6025E has 100 pins that you can connect to 100-pin accessories with the SH100100 shielded cable. You can connect your board to 68-pin accessories with the SH1006868 shielded cable, or to 50-pin accessories with the R1005050 ribbon cable.



**Caution** *Connections that exceed any of the maximum ratings of input or output signals on the boards can damage the board and the computer. Maximum input ratings for each signal are given in the Protection column of Table 4-2. National Instruments is NOT liable for any damages resulting from such signal connections.*

## I/O Connector

---

Figure 4-1 shows the pin assignments for the 68-pin I/O connector on the 6023 and 6024E. Figure 4-2 shows the pin assignments for the 100-pin I/O connector on the 6025E. Refer to Appendix B, [Custom Cabling and Optional Connectors](#), for pin assignments of the optional 50- and 68-pin connectors. A signal description follows the figures.



ACH8	34	68	ACH0
ACH1	33	67	AIGND
AIGND	32	66	ACH9
ACH10	31	65	ACH2
ACH3	30	64	AIGND
AIGND	29	63	ACH11
ACH4	28	62	AISENSE
AIGND	27	61	ACH12
ACH13	26	60	ACH5
ACH6	25	59	AIGND
AIGND	24	58	ACH14
ACH15	23	57	ACH7
DAC0OUT <sup>1</sup>	22	56	AIGND
DAC1OUT <sup>1</sup>	21	55	AOGND
RESERVED	20	54	AOGND
DIO4	19	53	DGND
DGND	18	52	DIO0
DIO1	17	51	DIO5
DIO6	16	50	DGND
DGND	15	49	DIO2
+5 V	14	48	DIO7
DGND	13	47	DIO3
DGND	12	46	SCANCLK
PFI0/TRIG1	11	45	EXTSTROBE*
PFI1/TRIG2	10	44	DGND
DGND	9	43	PFI2/CONVERT*
+5 V	8	42	PFI3/GPCTR1_SOURCE
DGND	7	41	PFI4/GPCTR1_GATE
PFI5/UPDATE*	6	40	GPCTR1_OUT
PFI6/WFTRIG	5	39	DGND
DGND	4	38	PFI7/STARTSCAN
PFI9/GPCTR0_GATE	3	37	PFI8/GPCTR0_SOURCE
GPCTR0_OUT	2	36	DGND
FREQ_OUT	1	35	DGND

<sup>1</sup> Not available on the 6023E

**Figure 4-1.** I/O Connector Pin Assignment for the 6023E/6024E

AIGND	1	51	PC7
AIGND	2	52	GND
ACH0	3	53	PC6
ACH8	4	54	GND
ACH1	5	55	PC5
ACH9	6	56	GND
ACH2	7	57	PC4
ACH10	8	58	GND
ACH3	9	59	PC3
ACH11	10	60	GND
ACH4	11	61	PC2
ACH12	12	62	GND
ACH5	13	63	PC1
ACH13	14	64	GND
ACH6	15	65	PC0
ACH14	16	66	GND
ACH7	17	67	PB7
ACH15	18	68	GND
AISENSE	19	69	PB6
DAC0OUT	20	70	GND
DAC1OUT	21	71	PB5
RESERVED	22	72	GND
AOGND	23	73	PB4
DGND	24	74	GND
DIO0	25	75	PB3
DIO4	26	76	GND
DIO1	27	77	PB2
DIO5	28	78	GND
DIO2	29	79	PB1
DIO6	30	80	GND
DIO3	31	81	PB0
DIO7	32	82	GND
DGND	33	83	PA7
+5 V	34	84	GND
+5 V	35	85	PA6
SCANCLK	36	86	GND
EXTSTROBE*	37	87	PA5
PFI0/TRIG1	38	88	GND
PFI1/TRIG2	39	89	PA4
PFI2/CONVERT*	40	90	GND
PFI3/GPCTR1_SOURCE	41	91	PA3
PFI4/GPCTR1_GATE	42	92	GND
GPCTR1_OUT	43	93	PA2
PFI5/UPDATE*	44	94	GND
PFI6/WFTRIG	45	95	PA1
PFI7/STARTSCAN	46	96	GND
PFI8/GPCTR0_SOURCE	47	97	PA0
PFI9/GPCTR0_GATE	48	98	GND
GPCTR0_OUT	49	99	+5 V
FREQ_OUT	50	100	GND

**Figure 4-2.** I/O Connector Pin Assignment for the 6025E

Table 4-1 shows the I/O connector signal descriptions for the 6023E, 6024E, and 6025E.

**Table 4-1.** I/O Connector Signal Descriptions

Signal Name	Reference	Direction	Description
AIGND	—	—	Analog Input Ground—These pins are the reference point for single-ended measurements in RSE configuration and the bias current return point for differential measurements. All three ground references—AIGND, AOGND, and DGND—are connected together on your board.
ACH<0..15>	AIGND	Input	Analog Input Channels 0 through 15—Each channel pair, ACH< <i>i, i+8</i> > ( <i>i</i> = 0..7), can be configured as either one differential input or two single-ended inputs.
AISENSE	AIGND	Input	Analog Input Sense—This pin serves as the reference node for any of channels ACH <0..15> in NRSE configuration.
DAC0OUT <sup>1</sup>	AOGND	Output	Analog Channel 0 Output—This pin supplies the voltage output of analog output channel 0.
DAC1OUT <sup>1</sup>	AOGND	Output	Analog Channel 1 Output—This pin supplies the voltage output of analog output channel 1.
AOGND	—	—	Analog Output Ground—The analog output voltages are referenced to this node. All three ground references—AIGND, AOGND, and DGND—are connected together on your board.
DGND	—	—	Digital Ground—This pin supplies the reference for the digital signals at the I/O connector as well as the +5 VDC supply. All three ground references—AIGND, AOGND, and DGND—are connected together on your board.
DIO<0..7>	DGND	Input or Output	Digital I/O signals—DIO6 and 7 can control the up/down signal of general-purpose counters 0 and 1, respectively.
PA<0..7> <sup>2</sup>	DGND	Input or Output	Port A bidirectional digital data lines for the 82C55A programmable peripheral interface on the 6025E. PA7 is the MSB. PA0 is the LSB.
PB<0..7> <sup>2</sup>	DGND	Input or Output	Port B bidirectional digital data lines for the 82C55A programmable peripheral interface on the 6025E. PB7 is the MSB. PB0 is the LSB.
PC<0..7> <sup>2</sup>	DGND	Input or Output	Port C bidirectional digital data lines for the 82C55A programmable peripheral interface on the 6025E. PC7 is the MSB. PC0 is the LSB.
+5 V	DGND	Output	+5 VDC Source—These pins are fused for up to 1 A of +5 V supply. The fuse is self-resetting.

**Table 4-1.** I/O Connector Signal Descriptions (Continued)

Signal Name	Reference	Direction	Description
SCANCLK	DGND	Output	Scan Clock—This pin pulses once for each A/D conversion in scanning mode when enabled. The low-to-high edge indicates when the input signal can be removed from the input or switched to another signal.
EXTSTROBE*	DGND	Output	External Strobe—This output can be toggled under software control to latch signals or trigger events on external devices.
PFI0/TRIG1	DGND	Input  Output	PFI0/Trigger 1—As an input, this is one of the Programmable Function Inputs (PFIs). PFI signals are explained in the <i>Timing Connections</i> section later in this chapter.  As an output, this is the TRIG1 (AI Start Trigger) signal. In posttrigger data acquisition sequences, a low-to-high transition indicates the initiation of the acquisition sequence. In pretrigger applications, a low-to-high transition indicates the initiation of the pretrigger conversions.
PFI1/TRIG2	DGND	Input  Output	PFI1/Trigger 2—As an input, this is one of the PFIs.  As an output, this is the TRIG2 (AI Stop Trigger) signal. In pretrigger applications, a low-to-high transition indicates the initiation of the posttrigger conversions. TRIG2 is not used in posttrigger applications.
PFI2/CONVERT*	DGND	Input  Output	PFI2/Convert—As an input, this is one of the PFIs.  As an output, this is the CONVERT* (AI Convert) signal. A high-to-low edge on CONVERT* indicates that an A/D conversion is occurring.
PFI3/GPCTR1_SOURCE	DGND	Input  Output	PFI3/Counter 1 Source—As an input, this is one of the PFIs.  As an output, this is the GPCTR1_SOURCE signal. This signal reflects the actual source connected to the general-purpose counter 1.
PFI4/GPCTR1_GATE	DGND	Input  Output	PFI4/Counter 1 Gate—As an input, this is one of the PFIs.  As an output, this is the GPCTR1_GATE signal. This signal reflects the actual gate signal connected to the general-purpose counter 1.
GPCTR1_OUT	DGND	Output	Counter 1 Output—This output is from the general-purpose counter 1 output.

**Table 4-1.** I/O Connector Signal Descriptions (Continued)

Signal Name	Reference	Direction	Description
PFI5/UPDATE*	DGND	Input Output	PFI5/Update—As an input, this is one of the PFIs.  As an output, this is the UPDATE* (AO Update) signal. A high-to-low edge on UPDATE* indicates that the analog output primary group is being updated for the 6024E or 6025E.
PFI6/WFTRIG	DGND	Input Output	PFI6/Waveform Trigger—As an input, this is one of the PFIs.  As an output, this is the WFTRIG (AO Start Trigger) signal. In timed analog output sequences, a low-to-high transition indicates the initiation of the waveform generation.
PFI7/STARTSCAN	DGND	Input Output	PFI7/Start of Scan—As an input, this is one of the PFIs.  As an output, this is the STARTSCAN (AI Scan Start) signal. This pin pulses once at the start of each analog input scan in the interval scan. A low-to-high transition indicates the start of the scan.
PFI8/GPCTR0_SOURCE	DGND	Input Output	PFI8/Counter 0 Source—As an input, this is one of the PFIs.  As an output, this is the GPCTR0_SOURCE signal. This signal reflects the actual source connected to the general-purpose counter 0.
PFI9/GPCTR0_GATE	DGND	Input Output	PFI9/Counter 0 Gate—As an input, this is one of the PFIs.  As an output, this is the GPCTR0_GATE signal. This signal reflects the actual gate signal connected to the general-purpose counter 0.
GPCTR0_OUT	DGND	Output	Counter 0 Output—This output is from the general-purpose counter 0 output.
FREQ_OUT	DGND	Output	Frequency Output—This output is from the frequency generator output.
<p>* Indicates that the signal is active low</p> <p><sup>1</sup> Not available on the 6023E</p> <p><sup>2</sup> Not available on the 6023E or 6024E</p>			

Table 4-2 shows the I/O signal summary for the 6023E, 6024E, and 6025E.

**Table 4-2.** I/O Signal Summary

Signal Name	Signal Type and Direction	Impedance Input/ Output	Protection (Volts) On/Off	Source (mA at V)	Sink (mA at V)	Rise Time (ns)	Bias
ACH<0..15>	AI	100 G $\Omega$ in parallel with 100 pF	42/35	—	—	—	$\pm 200$ pA
AISENSE	AI	100 G $\Omega$ in parallel with 100 pF	40/25	—	—	—	$\pm 200$ pA
AIGND	AO	—	—	—	—	—	—
DAC0OUT (6024E and 6025E only)	AO	0.1 $\Omega$	Short-circuit to ground	5 at 10	5 at -10	10 V/ $\mu$ s	—
DAC1OUT (6024E and 6025E only)	AO	0.1 $\Omega$	Short-circuit to ground	5 at 10	5 at -10	10 V/ $\mu$ s	—
AOGND	AO	—	—	—	—	—	—
DGND	DO	—	—	—	—	—	—
VCC	DO	0.1 $\Omega$	Short-circuit to ground	1A fused	—	—	—
DIO<0..7>	DIO	—	V <sub>cc</sub> +0.5	13 at (V <sub>cc</sub> -0.4)	24 at 0.4	1.1	50 k $\Omega$ pu
PA<0..7> (6025E only)	DIO	—	V <sub>cc</sub> +0.5	2.5 at 3.7min	2.5 at 0.4	5	100 k $\Omega$ pu
PB<0..7> (6025E only)	DIO	—	V <sub>cc</sub> +0.5	2.5 at 3.7min	2.5 at 0.4	5	100 k $\Omega$ pu
PC<0..7> (6025E only)	DIO	—	V <sub>cc</sub> +0.5	2.5 at 3.7min	2.5 at 0.4	5	100 k $\Omega$ pu
SCANCLK	DO	—	—	3.5 at (V <sub>cc</sub> -0.4)	5 at 0.4	1.5	50 k $\Omega$ pu
EXTSTROBE*	DO	—	—	3.5 at (V <sub>cc</sub> -0.4)	5 at 0.4	1.5	50 k $\Omega$ pu
PFI0/TRIG1	DIO	—	V <sub>cc</sub> +0.5	3.5 at (V <sub>cc</sub> -0.4)	5 at 0.4	1.5	50 k $\Omega$ pu
PFI1/TRIG2	DIO	—	V <sub>cc</sub> +0.5	3.5 at (V <sub>cc</sub> -0.4)	5 at 0.4	1.5	50 k $\Omega$ pu
PFI2/CONVERT*	DIO	—	V <sub>cc</sub> +0.5	3.5 at (V <sub>cc</sub> -0.4)	5 at 0.4	1.5	50 k $\Omega$ pu
PFI3/GPCTR1_SOURCE	DIO	—	V <sub>cc</sub> +0.5	3.5 at (V <sub>cc</sub> -0.4)	5 at 0.4	1.5	50 k $\Omega$ pu

**Table 4-2.** I/O Signal Summary (Continued)

Signal Name	Signal Type and Direction	Impedance Input/ Output	Protection (Volts) On/Off	Source (mA at V)	Sink (mA at V)	Rise Time (ns)	Bias
PFI4/GPCTR1_GATE	DIO	—	V <sub>cc</sub> +0.5	3.5 at (V <sub>cc</sub> -0.4)	5 at 0.4	1.5	50 kΩ pu
GPCTR1_OUT	DO	—	—	3.5 at (V <sub>cc</sub> -0.4)	5 at 0.4	1.5	50 kΩ pu
PFI5/UPDATE*	DIO	—	V <sub>cc</sub> +0.5	3.5 at (V <sub>cc</sub> -0.4)	5 at 0.4	1.5	50 kΩ pu
PFI6/WFTRIG	DIO	—	V <sub>cc</sub> +0.5	3.5 at (V <sub>cc</sub> -0.4)	5 at 0.4	1.5	50 kΩ pu
PFI7/STARTSCAN	DIO	—	V <sub>cc</sub> +0.5	3.5 at (V <sub>cc</sub> -0.4)	5 at 0.4	1.5	50 kΩ pu
PFI8/GPCTR0_SOURCE	DIO	—	V <sub>cc</sub> +0.5	3.5 at (V <sub>cc</sub> -0.4)	5 at 0.4	1.5	50 kΩ pu
PFI9/GPCTR0_GATE	DIO	—	V <sub>cc</sub> +0.5	3.5 at (V <sub>cc</sub> -0.4)	5 at 0.4	1.5	50 kΩ pu
GPCTR0_OUT	DO	—	—	3.5 at (V <sub>cc</sub> -0.4)	5 at 0.4	1.5	50 kΩ pu
FREQ_OUT	DO	—	—	3.5 at (V <sub>cc</sub> -0.4)	5 at 0.4	1.5	50 kΩ pu
AI = Analog Input      DIO = Digital Input/Output      pu = pullup AO = Analog Output      DO = Digital Output  <b>Note:</b> The tolerance on the 50 kΩ pullup and pulldown resistors is very large. Actual value may range between 17 kΩ and 100 kΩ.							

## Analog Input Signal Overview

The analog input signals for these boards are ACH<0..15>, ASENSE, and AIGND. Connection of these analog input signals to your board depends on the type of input signal source and the configuration of the analog input channels you are using. This section provides an overview of the different types of signal sources and analog input configuration modes. More specific signal connection information is provided in the section, [Analog Input Signal Connections](#).

### Types of Signal Sources

When configuring the input channels and making signal connections, you must first determine whether the signal sources are floating or ground-referenced.

#### Floating Signal Sources

A floating signal source is not connected in any way to the building ground system but, rather, has an isolated ground-reference point. Some examples of floating signal sources are outputs of transformers, thermocouples,

battery-powered devices, optical isolators, and isolation amplifiers. An instrument or device that has an isolated output is a floating signal source. You must tie the ground reference of a floating signal to your board's analog input ground to establish a local or onboard reference for the signal. Otherwise, the measured input signal varies as the source floats out of the common-mode input range.

## Ground-Referenced Signal Sources

A ground-referenced signal source is connected in some way to the building system ground and is, therefore, already connected to a common ground point with respect to the board, assuming that the computer is plugged into the same power system. Nonisolated outputs of instruments and devices that plug into the building power system fall into this category.

The difference in ground potential between two instruments connected to the same building power system is typically between 1 and 100 mV but can be much higher if power distribution circuits are not properly connected. If a grounded signal source is improperly measured, this difference may appear as an error in the measurement. The connection instructions for grounded signal sources are designed to eliminate this ground potential difference from the measured signal.

## Analog Input Modes

You can configure your board for one of three input modes: nonreferenced single ended (NRSE), referenced single ended (RSE), and differential (DIFF). With the different configurations, you can use the PGIA in different ways. Figure 4-3 shows a diagram of your board's PGIA.



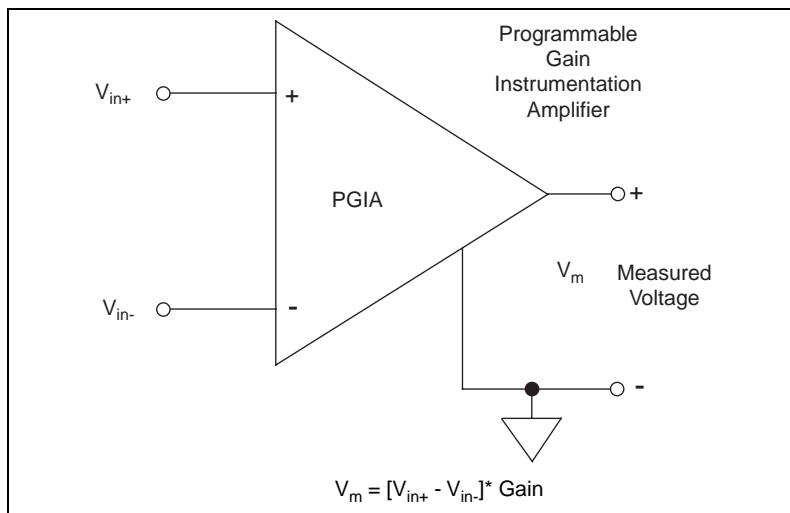

**Figure 4-3.** Programmable Gain Instrumentation Amplifier (PGIA)

In single-ended mode (RSE and NRSE), signals connected to ACH<0..15> are routed to the positive input of the PGIA. In differential mode, signals connected to ACH<0..7> are routed to the positive input of the PGIA, and signals connected to ACH<8..15> are routed to the negative input of the PGIA.



**Caution** *Exceeding the differential and common-mode input ranges distorts your input signals. Exceeding the maximum input voltage rating can damage the board and the computer. National Instruments is NOT liable for any damages resulting from such signal connections. The maximum input voltage ratings are listed in the Protection column of Table 4-2.*

In NRSE mode, the AISENSE signal is connected internally to the negative input of the PGIA when their corresponding channels are selected. In DIFF and RSE modes, AISENSE is left unconnected.

AIGND is an analog input common signal that is routed directly to the ground tie point on the boards. You can use this signal for a general analog ground tie point to your board if necessary.

The PGIA applies gain and common-mode voltage rejection and presents high input impedance to the analog input signals connected to your board. Signals are routed to the positive and negative inputs of the PGIA through input multiplexers on the board. The PGIA converts two input signals to a signal that is the difference between the two input signals multiplied by the gain setting of the amplifier. The amplifier output voltage is referenced to

the ground for the board. Your board's A/D converter (ADC) measures this output voltage when it performs A/D conversions.

You must reference all signals to ground either at the source device or at the board. If you have a floating source, you should reference the signal to ground by using the RSE input mode or the DIFF input configuration with bias resistors (see the *Differential Connections for Nonreferenced or Floating Signal Sources* section in this chapter). If you have a grounded source, you should not reference the signal to AIGND. You can avoid this reference by using DIFF or NRSE input configurations.

## Analog Input Signal Connections

---

The following sections discuss the use of single-ended and differential measurements and recommendations for measuring both floating and ground-referenced signal sources.

Figure 4-4 summarizes the recommended input configuration for both types of signal sources.

Input	Signal Source Type	
	Floating Signal Source (Not Connected to Building Ground)	Grounded Signal Source
	<p>Examples</p> <ul style="list-style-type: none"> <li>• Ungrounded Thermocouples</li> <li>• Signal conditioning with isolated outputs</li> <li>• Battery devices</li> </ul>	<p>Examples</p> <ul style="list-style-type: none"> <li>• Plug-in instruments with nonisolated outputs</li> </ul>
Differential (DIFF)	<p>See text for information on bias resistors.</p>	
Single-Ended — Ground Referenced (RSE)		<p><b>NOT RECOMMENDED</b></p> <p>Ground-loop losses, <math>V_g</math>, are added to measured signal</p>
Single-Ended — Nonreferenced (NRSE)	<p>See text for information on bias resistors.</p>	

Figure 4-4. Summary of Analog Input Connections

## Differential Connection Considerations (DIFF Input Configuration)

A differential connection is one in which the analog input signal has its own reference signal or signal return path. These connections are available when the selected channel is configured in DIFF input mode. The input signal is tied to the positive input of the PGIA, and its reference signal, or return, is tied to the negative input of the PGIA.

When you configure a channel for differential input, each signal uses two multiplexer inputs—one for the signal and one for its reference signal. Therefore, with a differential configuration for every channel, up to eight analog input channels are available.

You should use differential input connections for any channel that meets any of the following conditions:

- The input signal is low level (less than 1 V).
- The leads connecting the signal to the board are greater than 10 ft (3 m).
- The input signal requires a separate ground-reference point or return signal.
- The signal leads travel through noisy environments.

Differential signal connections reduce picked up noise and increase common-mode noise rejection. Differential signal connections also allow input signals to float within the common-mode limits of the PGIA.

## Differential Connections for Ground-Referenced Signal Sources

Figure 4-5 shows how to connect a ground-referenced signal source to a channel on the board configured in DIFF input mode.

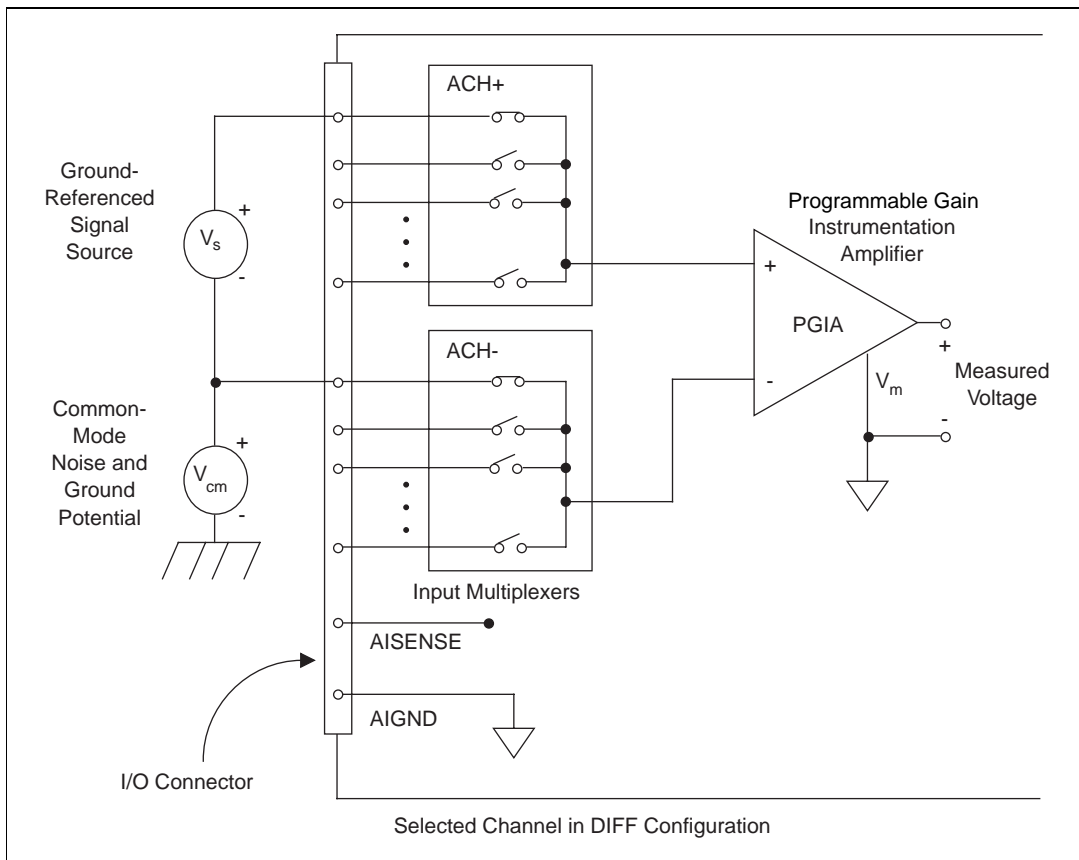
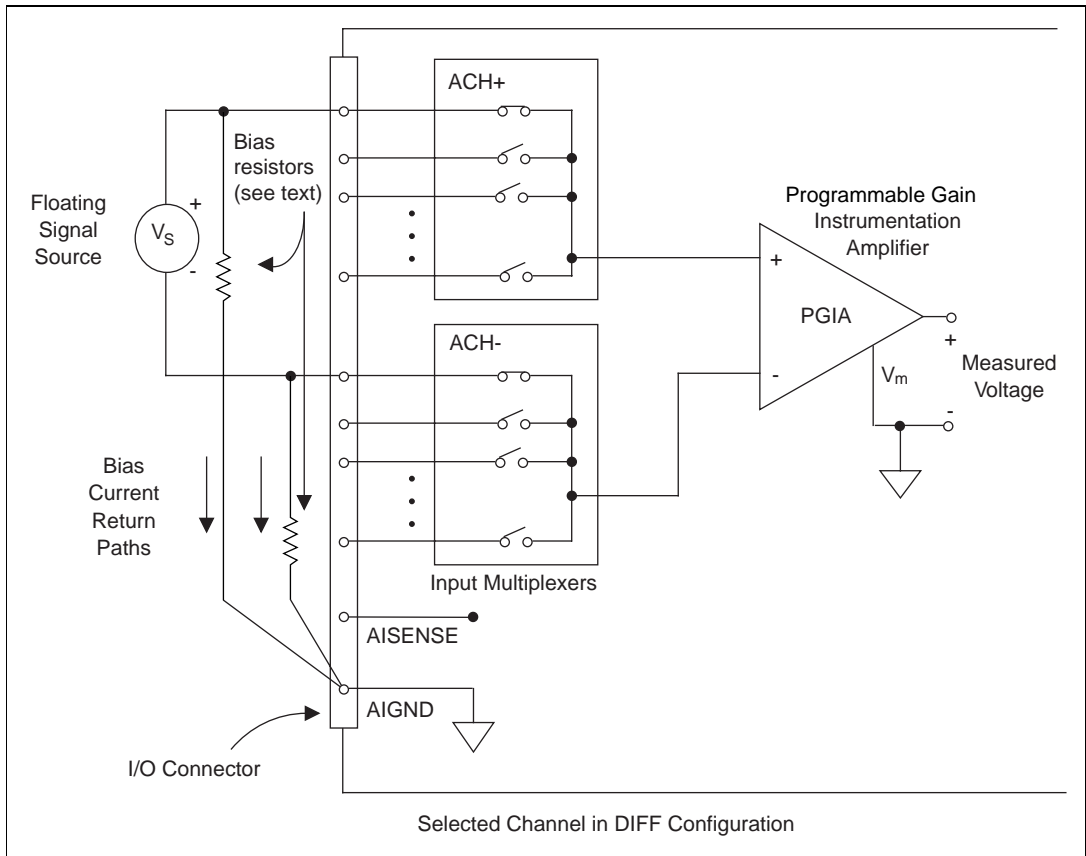

**Figure 4-5.** Differential Input Connections for Ground-Referenced Signals

With this type of connection, the PGIA rejects both the common-mode noise in the signal and the ground potential difference between the signal source and the board ground, shown as  $V_{cm}$  in Figure 4-5.

## Differential Connections for Nonreferenced or Floating Signal Sources

Figure 4-6 shows how to connect a floating signal source to a channel configured in DIFF input mode.



**Figure 4-6.** Differential Input Connections for Nonreferenced Signals

Figure 4-6 shows two bias resistors connected in parallel with the signal leads of a floating signal source. If you do not use the resistors and the source is truly floating, the source is not likely to remain within the common-mode signal range of the PGIA. The PGIA will then saturate, causing erroneous readings.

You must reference the source to AIGND. The easiest way is to connect the positive side of the signal to the positive input of the PGIA and connect the negative side of the signal to AIGND as well as to the negative input of the PGIA, without any resistors at all. This connection works well for DC-coupled sources with low source impedance (less than 100  $\Omega$ ).

However, for larger source impedances, this connection leaves the differential signal path significantly out of balance. Noise that couples electrostatically onto the positive line does not couple onto the negative line because it is connected to ground. Hence, this noise appears as a differential-mode signal instead of a common-mode signal, and the PGIA does not reject it. In this case, instead of directly connecting the negative line to AIGND, connect it to AIGND through a resistor that is about 100 times the equivalent source impedance. The resistor puts the signal path nearly in balance, so that about the same amount of noise couples onto both connections, yielding better rejection of electrostatically coupled noise. Also, this configuration does not load down the source (other than the very high input impedance of the PGIA).

You can fully balance the signal path by connecting another resistor of the same value between the positive input and AIGND, as shown in Figure 4-6. This fully balanced configuration offers slightly better noise rejection but has the disadvantage of loading the source down with the series combination (sum) of the two resistors. If, for example, the source impedance is 2 k $\Omega$  and each of the two resistors is 100 k $\Omega$ , the resistors load down the source with 200 k $\Omega$  and produce a -1% gain error.

Both inputs of the PGIA require a DC path to ground in order for the PGIA to work. If the source is AC coupled (capacitively coupled), the PGIA needs a resistor between the positive input and AIGND. If the source has low impedance, choose a resistor that is large enough not to significantly load the source but small enough not to produce significant input offset voltage as a result of input bias current (typically 100 k $\Omega$  to 1 M $\Omega$ ). In this case, you can tie the negative input directly to AIGND. If the source has high output impedance, you should balance the signal path as previously described using the same value resistor on both the positive and negative inputs; you should be aware that there is some gain error from loading down the source.

## Single-Ended Connection Considerations

A single-ended connection is one in which the board analog input signal is referenced to a ground that can be shared with other input signals. The input signal is tied to the positive input of the PGIA, and the ground is tied to the negative input of the PGIA.

When every channel is configured for single-ended input, up to 16 analog input channels are available.

You can use single-ended input connections for any input signal that meets the following conditions:

- The input signal is high level (greater than 1 V).
- The leads connecting the signal to the board are less than 10 ft (3 m).
- The input signal can share a common reference point with other signals.

DIFF input connections are recommended for greater signal integrity for any input signal that does not meet the preceding conditions.

Using your software, you can configure the channels for two different types of single-ended connections—RSE configuration and NRSE configuration. The RSE configuration is used for floating signal sources; in this case, the board provides the reference ground point for the external signal. The NRSE input configuration is used for ground-referenced signal sources; in this case, the external signal supplies its own reference ground point and the board should not supply one.

In single-ended configurations, more electrostatic and magnetic noise couples into the signal connections than in differential configurations. The coupling is the result of differences in the signal path. Magnetic coupling is proportional to the area between the two signal conductors. Electrical coupling is a function of how much the electric field differs between the two conductors.



## Single-Ended Connections for Floating Signal Sources (RSE Configuration)

Figure 4-7 shows how to connect a floating signal source to a channel configured for RSE mode.

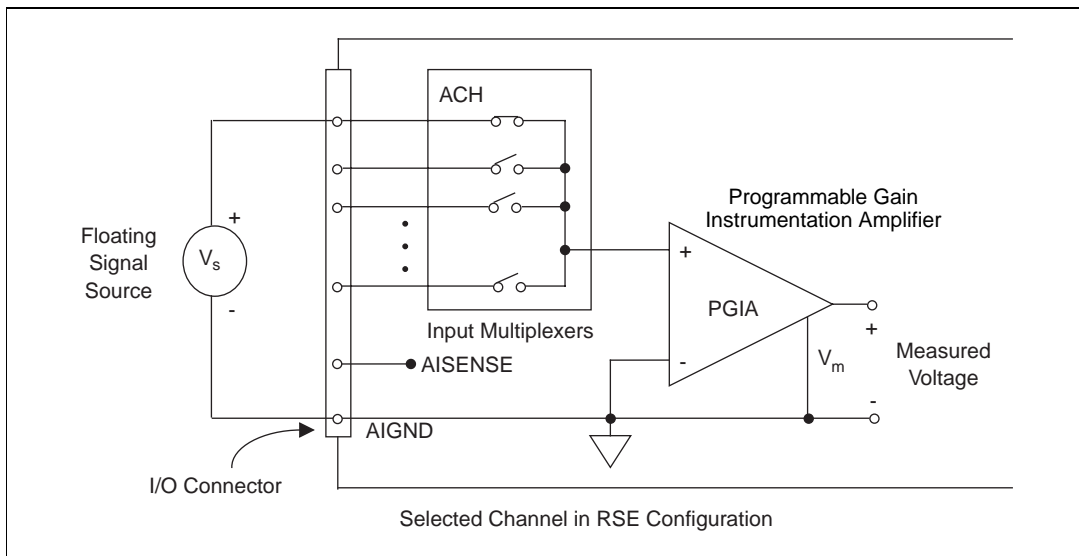
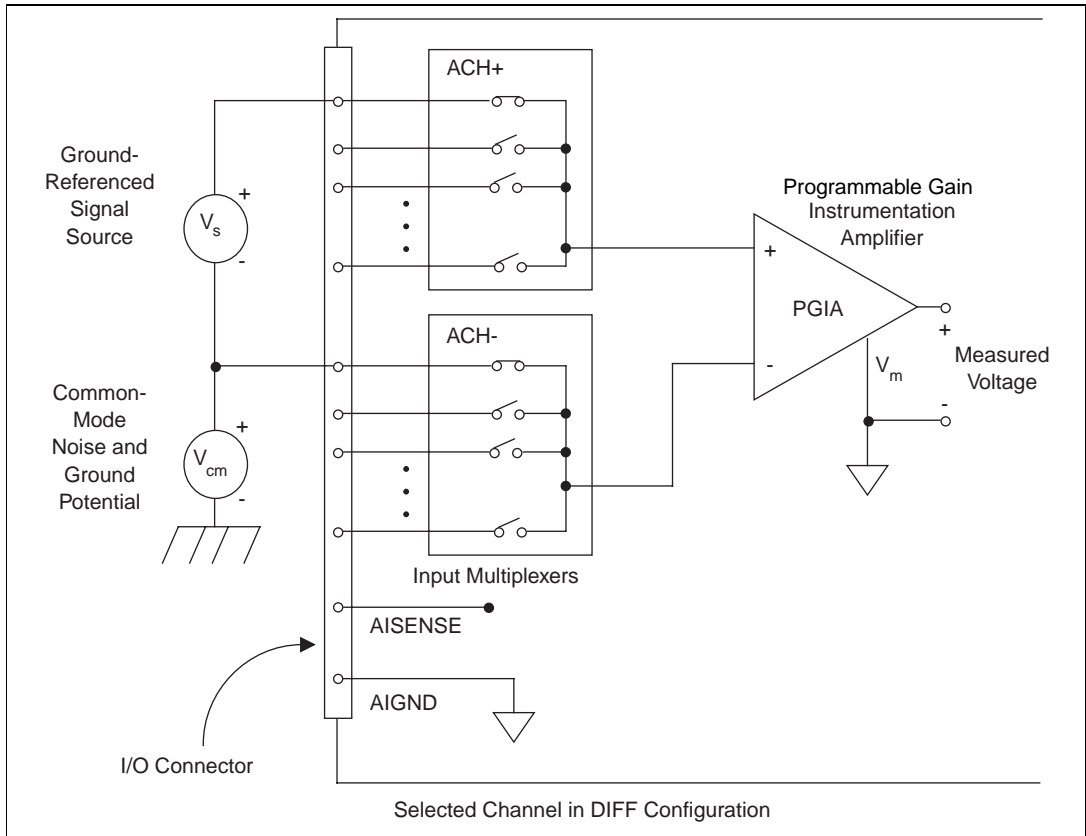

**Figure 4-7.** Single-Ended Input Connections for Nonreferenced or Floating Signals

## Single-Ended Connections for Grounded Signal Sources (NRSE Configuration)

To measure a grounded signal source with a single-ended configuration, you must configure your board in the NRSE input configuration. The signal is then connected to the positive input of the PGIA, and the signal local ground reference is connected to the negative input of the PGIA. The ground point of the signal should, therefore, be connected to the AISENSE pin. Any potential difference between the board ground and the signal ground appears as a common-mode signal at both the positive and negative inputs of the PGIA, and this difference is rejected by the amplifier. If the input circuitry of a board were referenced to ground, in this situation as in the RSE input configuration, this difference in ground potentials would appear as an error in the measured voltage.

Figure 4-8 shows how to connect a grounded signal source to a channel configured for NRSE mode.



**Figure 4-8.** Single-Ended Input Connections for Ground-Referenced Signals

## Common-Mode Signal Rejection Considerations

Figures 4-5 and 4-8 show connections for signal sources that are already referenced to some ground point with respect to the board. In these cases, the PGIA can reject any voltage caused by ground potential differences between the signal source and the board. In addition, with differential input connections, the PGIA can reject common-mode noise pickup in the leads connecting the signal sources to the board. The PGIA can reject common-mode signals as long as  $V_{+in}$  and  $V_{-in}$  (input signals) are both within  $\pm 11$  V of AIGND.

# Analog Output Signal Connections

◆ 6024E and 6025E

The analog output signals are DAC0OUT, DAC1OUT, and AOGND. DAC0OUT and DAC1OUT are not available on the 6023E.

DAC0OUT is the voltage output signal for analog output channel 0.  
 DAC1OUT is the voltage output signal for analog output channel 1.

AOGND is the ground reference signal for both analog output channels and the external reference signal.

Figure 4-9 shows how to make analog output connections to your board.

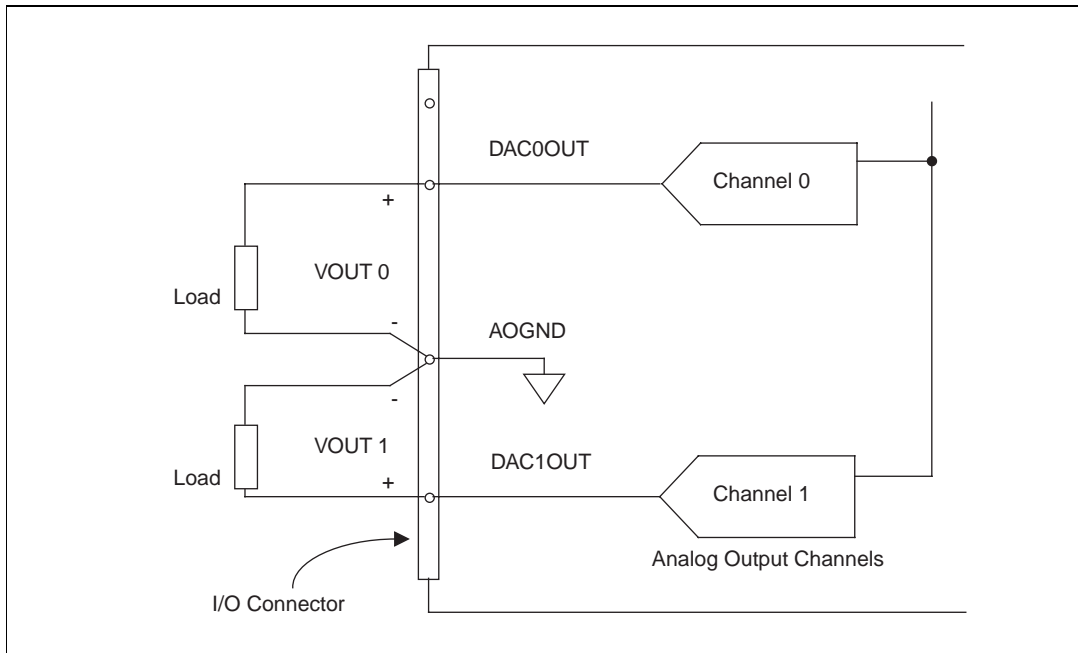
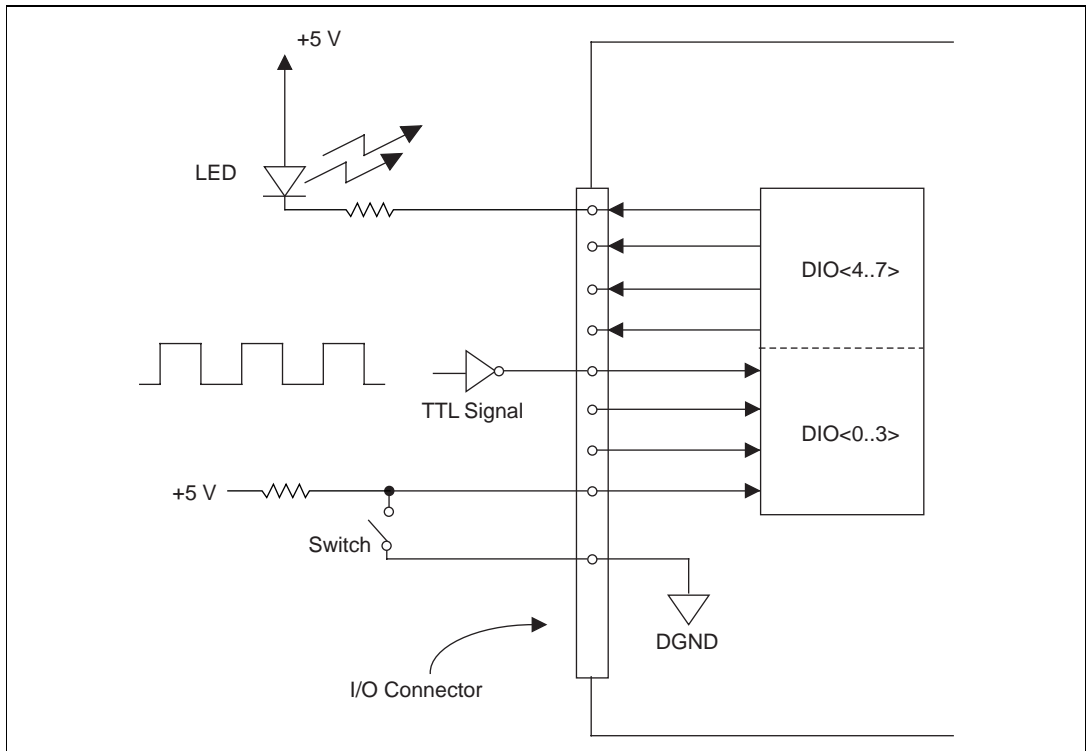

**Figure 4-9.** Analog Output Connections

# Digital I/O Signal Connections

## All Boards

All boards have digital I/O signals DIO<0..7> and DGND. DIO<0..7> are the signals making up the DIO port, and DGND is the ground reference signal for the DIO port. You can program all lines individually to be inputs or outputs. Figure 4-10 shows signal connections for three typical digital I/O applications.



**Figure 4-10.** Digital I/O Connections

Figure 4-10 shows DIO<0..3> configured for digital input and DIO<4..7> configured for digital output. Digital input applications include receiving TTL signals and sensing external device states such as the state of the switch shown in the figure. Digital output applications include sending TTL signals and driving external devices such as the LED shown in the figure.

# Programmable Peripheral Interface (PPI)

◆ 6025E only

The 6025E board uses an 82C55A PPI to provide an additional 24 lines of digital I/O that represent three 8-bit ports: PA, PB, and PC. Each port can be programmed as an input or output port.

Figure 4-11 depicts signal connections for three typical digital I/O applications.

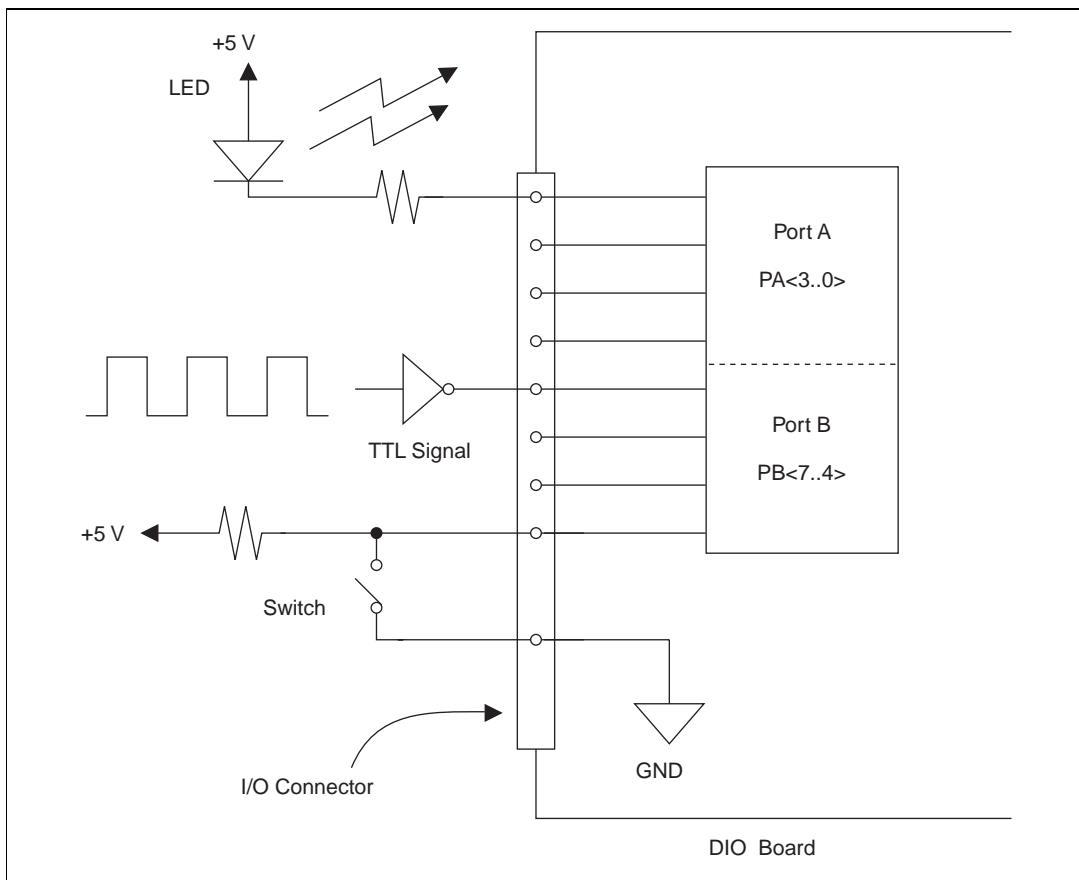

**Figure 4-11.** Digital I/O Connections Block Diagram

In Figure 4-11, port A of one PPI is configured for digital output, and port B is configured for digital input. Digital input applications include

receiving TTL signals and sensing external device states such as the state of the switch in Figure 4-11. Digital output applications include sending TTL signals and driving external devices such as the LED shown in Figure 4-11.

## Port C Pin Assignments

- ◆ 6025 only

The signals assigned to port C depend on how the 82C55A is configured. In mode 0, or no handshaking configuration, port C is configured as two 4-bit I/O ports. In modes 1 and 2, or handshaking configuration, port C is used for status and handshaking signals with any leftover lines available for general-purpose I/O. Table 4-3 summarizes the port C signal assignments for each configuration. You can also use ports A and B in different modes; the table does not show every possible combination.



### Note

*Table 4-3 shows both the port C signal assignments and the terminology correlation between different documentation sources. The 82C55A terminology refers to the different 82C55A configurations as modes, whereas NI-DAQ, ComponentWorks, LabWindows/CVI, and LabVIEW documentation refers to them as handshaking and no handshaking.*

**Table 4-3.** Port C Signal Assignments

Configuration Terminology		Signal Assignments							
<i>6023E/ 6024E/6025E User Manual</i>	National Instruments Software	PC7	PC6	PC5	PC4	PC3	PC2	PC1	PC0
Mode 0 (Basic I/O)	No Handshaking	I/O	I/O	I/O	I/O	I/O	I/O	I/O	I/O
Mode 1 (Strobed Input)	Handshaking	I/O	I/O	IBF <sub>A</sub>	STB <sub>A</sub> *	INTR <sub>A</sub>	STB <sub>B</sub> *	IBFB <sub>B</sub>	INTR <sub>B</sub>
Mode 1 (Strobed Output)	Handshaking	OBFA*	ACK <sub>A</sub> *	I/O	I/O	INTR <sub>A</sub>	ACK <sub>B</sub> *	OBFB*	INTR <sub>B</sub>
Mode 2 (Bidirectional Bus)	Handshaking	OBFA*	ACK <sub>A</sub> *	IBFA	STB <sub>A</sub> *	INTR <sub>A</sub>	I/O	I/O	I/O

\*Indicates that the signal is active low.  
Subscripts A and B denote port A or port B handshaking signals.

## Power-up State

### ◆ 6025E only

The 6025E contains bias resistors that control the state of the digital I/O lines PA<0..7>,PB<0..7>,PC<0..7> at power up. Each digital I/O line is configured as an input, pulled high by a 100 k $\Omega$  bias resistor.

You can change individual lines from pulled up to pulled down by adding your own external resistors. This section describes the procedure.

## Changing DIO Power-up State to Pulled Low

Each DIO line is pulled to  $V_{cc}$  (approximately +5 VDC) with a 100 k $\Omega$  resistor. To pull a specific line low, connect between that line and ground a pull-down resistor ( $R_L$ ) whose value will give you a maximum of 0.4 VDC. The DIO lines provide a maximum of 2.5 mA at 3.7 V in the high state. Using the largest possible resistor ensures that you do not use more current than necessary to perform the pull-down task.

However, make sure the resistor's value is not so large that leakage current from the DIO line along with the current from the 100 k $\Omega$  pull-up resistor drives the voltage at the resistor above a TTL-low level of 0.4 VDC.

Figure 4-12 shows the DIO configuration for high DIO power-up state.

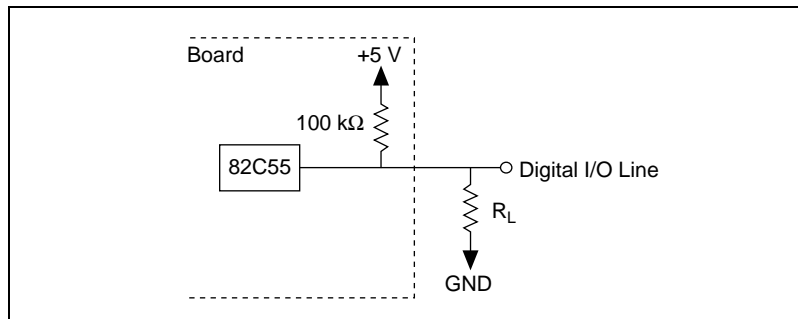

**Figure 4-12.** DIO Channel Configured for High DIO Power-up State with External Load

Example:

A given DIO line is pulled high at power up. To pull it low on power up with an external resistor, follow these steps:

1. Install a load ( $R_L$ ). Remember that the smaller the resistance, the greater the current consumption and the lower the voltage.

2. Using the following formula, calculate the largest possible load to maintain a logic low level of 0.4 V and supply the maximum driving current:

$$V = I * R_L \Rightarrow R_L = V/I, \text{ where:}$$

$$V = 0.4 \text{ V} \quad ; \text{ Voltage across } R_L$$

$$I = 46 \mu\text{A} + 10 \mu\text{A} \quad ; 4.6 \text{ V across the } 100 \text{ k}\Omega \text{ pull-up resistor and } 10 \mu\text{A maximum leakage current}$$

Therefore:

$$R_L = 7.1 \text{ k}\Omega \quad ; 0.4 \text{ V}/56 \mu\text{A}$$

This resistor value, 7.1 k $\Omega$ , provides a maximum of 0.4 V on the DIO line at power up. You can substitute smaller resistor values to lower the voltage or to provide a margin for  $V_{CC}$  variations and other factors. However, smaller values will draw more current, leaving less drive current for other circuitry connected to this line. The 7.1 k $\Omega$  resistor reduces the amount of logic high source current by 0.4 mA with a 2.8 V output.

## Timing Specifications

- ◆ 6025E only

This section lists the timing specifications for handshaking with your 6025E PC<0..7> lines. The handshaking lines STB\* and IBF synchronize input transfers. The handshaking lines OBF\* and ACK\* synchronize output transfers. Table 4-4 describes signals appearing in the handshaking diagrams.

**Table 4-4.** Signal Names Used in Timing Diagrams

Name	Type	Description
STB*	Input	Strobe Input—A low signal on this handshaking line loads data into the input latch.
IBF	Output	Input Buffer Full—A high signal on this handshaking line indicates that data has been loaded into the input latch. A low signal indicates the board is ready for more data. This is an input acknowledge signal.
ACK*	Input	Acknowledge Input—A low signal on this handshaking line indicates that the data written to the port has been accepted. This signal is a response from the external device indicating that it has received the data from your DIO board.

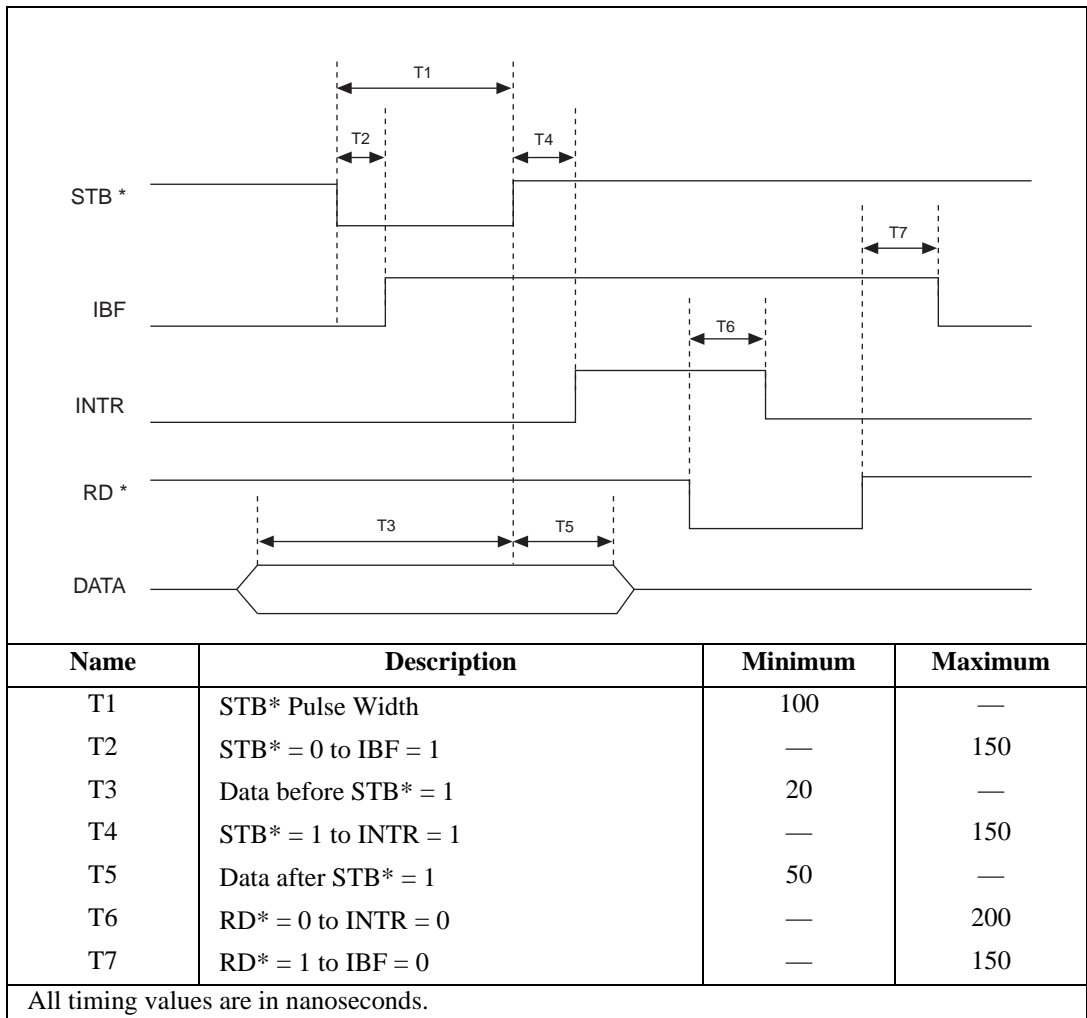

**Table 4-4.** Signal Names Used in Timing Diagrams (Continued)

Name	Type	Description
OBF*	Output	Output Buffer Full—A low signal on this handshaking line indicates that data has been written to the port.
INTR	Output	Interrupt Request—This signal becomes high when the 82C55A requests service during a data transfer. The appropriate interrupt enable bits must be set to generate this signal.
RD*	Internal	Read—This signal is the read signal generated from the control lines of the computer I/O expansion bus.
WR*	Internal	Write—This signal is the write signal generated from the control lines of the computer I/O expansion bus.
DATA	Bidirectional	Data Lines at the Specified Port—For output mode, this signal indicates the availability of data on the data line. For input mode, this signal indicates when the data on the data lines should be valid.

## Mode 1 Input Timing

Timing specifications for an input transfer in mode 1 are as follows:



**Figure 4-13.** Timing Specifications for Mode 1 Input Transfer

## Mode 1 Output Timing

Timing specifications for an output transfer in mode 1 are as follows:

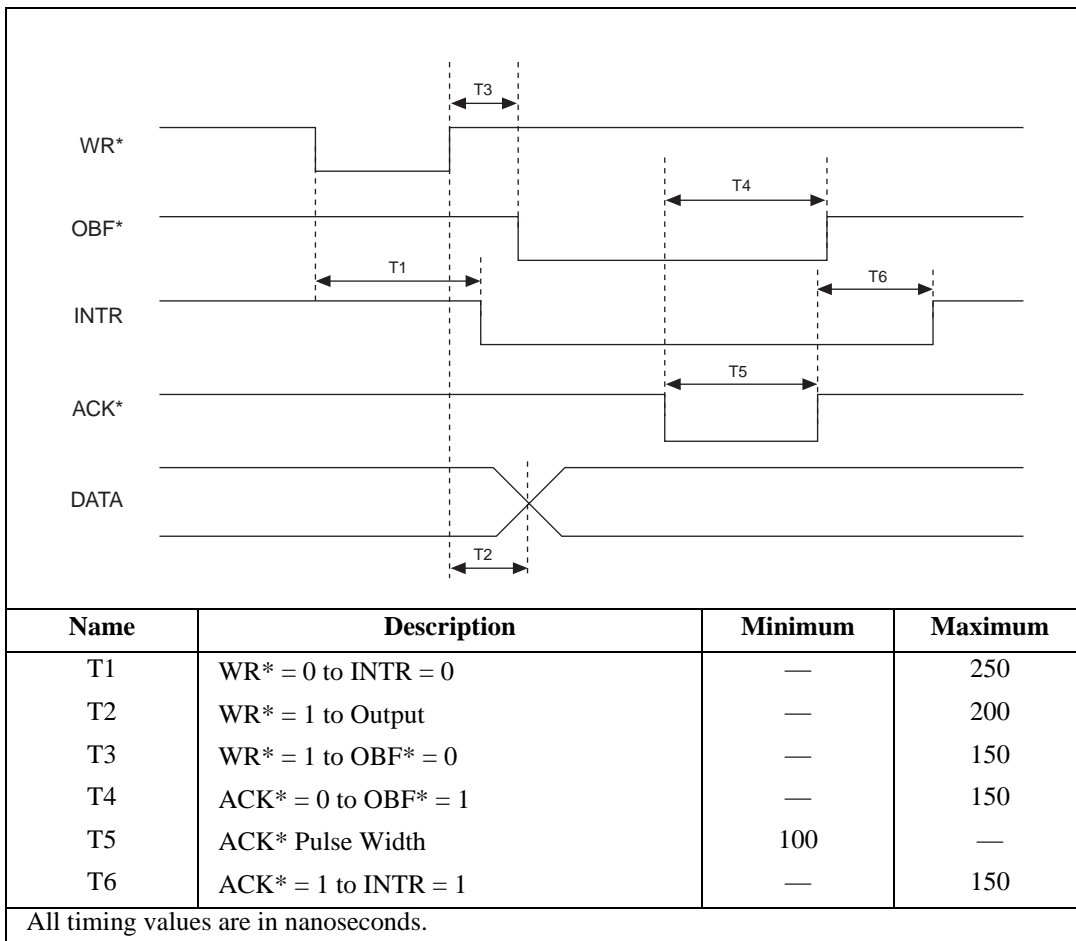

**Figure 4-14.** Timing Specifications for Mode 1 Output Transfer

## Mode 2 Bidirectional Timing

Timing specifications for a bidirectional transfer in mode 2 are as follows:

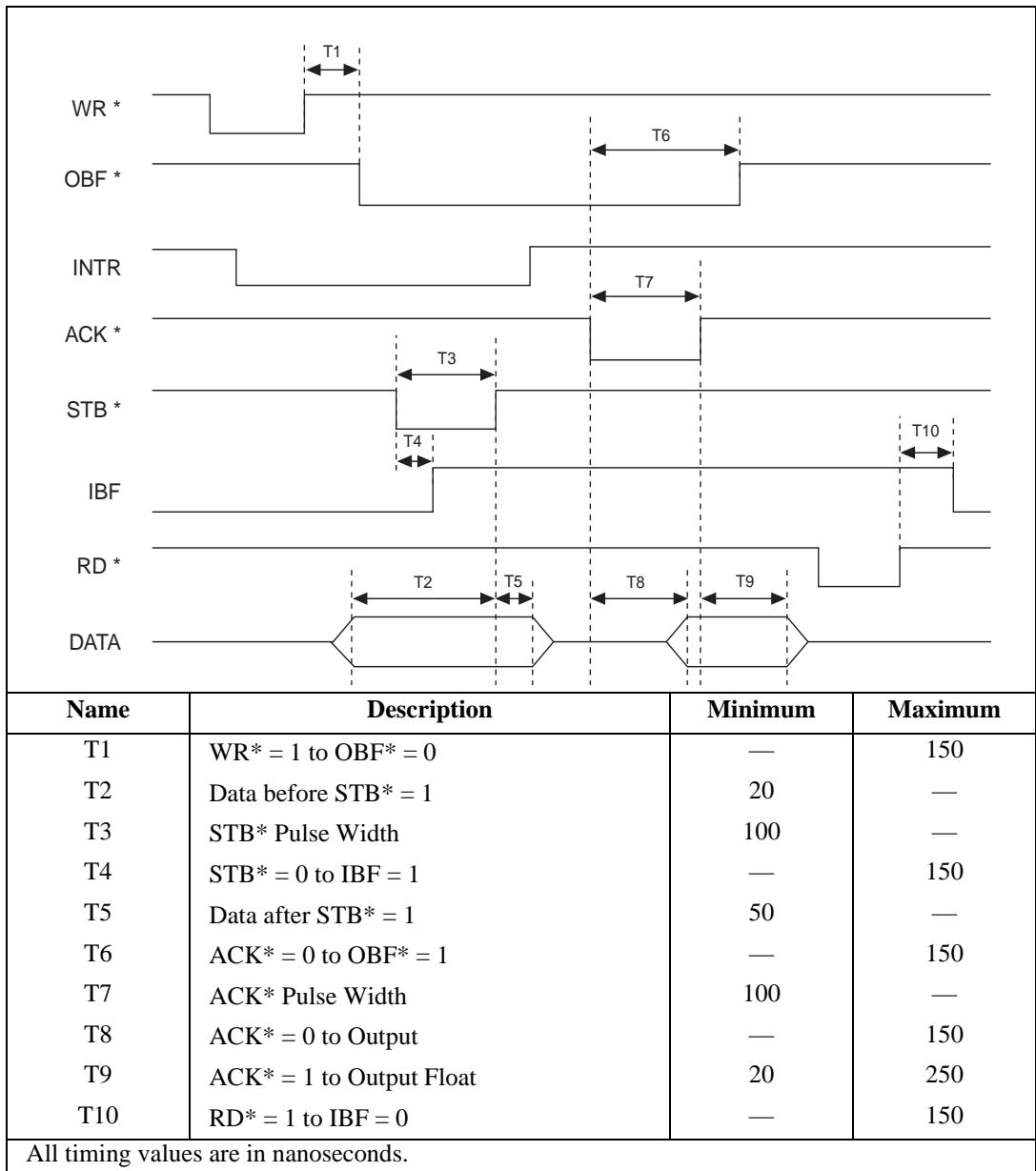

**Figure 4-15.** Timing Specifications for Mode 2 Bidirectional Transfer

## Power Connections

---

Two pins on the I/O connector supply +5 V from the computer power supply via a self-resetting fuse. The fuse will reset automatically within a few seconds after the overcurrent condition is removed. These pins are referenced to DGND and can be used to power external digital circuitry. The power rating is +4.65 to +5.25 VDC at 1 A.



**Caution** *Under no circumstances should you connect these +5 V power pins directly to analog or digital ground or to any other voltage source on the board or any other device. Doing so can damage the board and the computer. National Instruments is NOT liable for damages resulting from such a connection.*

## Timing Connections

---



**Caution** *Exceeding the maximum input voltage ratings, which are listed in Table 4-2, can damage the board and the computer. National Instruments is NOT liable for any damages resulting from such signal connections.*

All external control over the timing of your board is routed through the 10 programmable function inputs labeled PFI<0..9>. These signals are explained in detail in the section, [Programmable Function Input Connections](#). These PFIs are bidirectional; as outputs they are not programmable and reflect the state of many DAQ, waveform generation, and general-purpose timing signals. There are five other dedicated outputs for the remainder of the timing signals. As inputs, the PFI signals are programmable and can control any DAQ, waveform generation, and general-purpose timing signals.

The DAQ signals are explained in the [DAQ Timing Connections](#) section later in this chapter. The waveform generation signals are explained in the [Waveform Generation Timing Connections](#) section later in this chapter. The general-purpose timing signals are explained in the [General-Purpose Timing Signal Connections](#) section in this chapter.

All digital timing connections are referenced to DGND. This reference is demonstrated in Figure 4-16, which shows how to connect an external TRIG1 source and an external CONVERT\* source to two PFI pins.

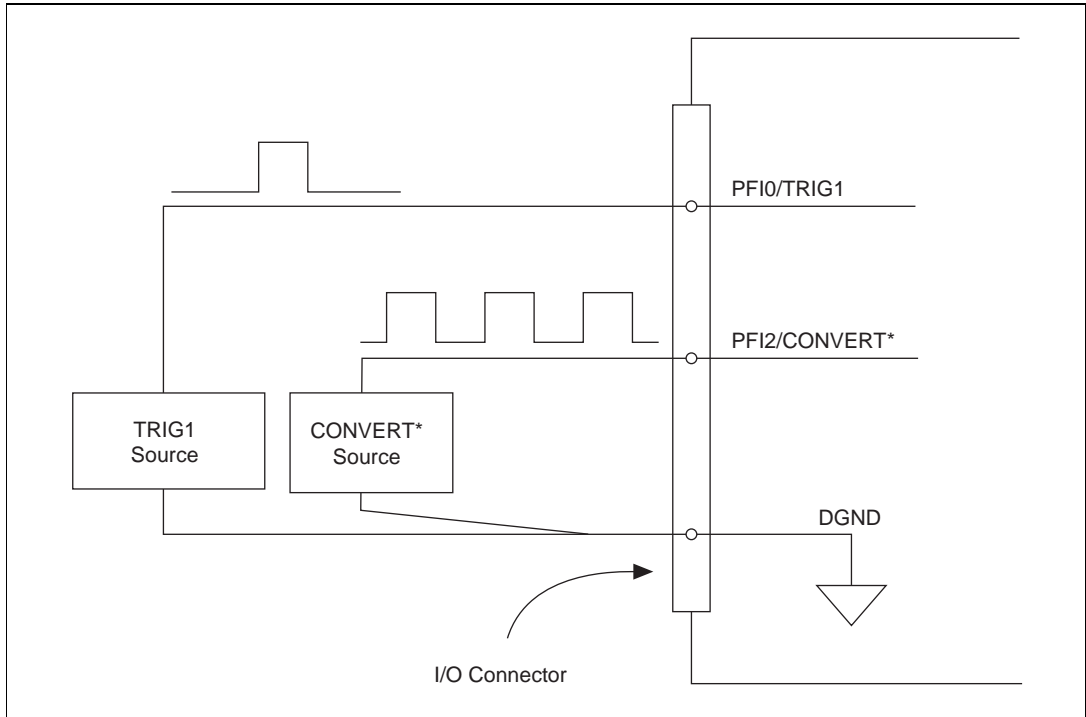

**Figure 4-16.** Timing I/O Connections

## Programmable Function Input Connections

There are a total of 13 internal timing signals that you can externally control from the PFI pins. The source for each of these signals is software-selectable from any of the PFIs when you want external control. This flexible routing scheme reduces the need to change the physical wiring to the board I/O connector for different applications requiring alternative wiring.

You can individually enable each of the PFI pins to output a specific internal timing signal. For example, if you need the CONVERT\* signal as an output on the I/O connector, software can turn on the output driver for the PFI2/CONVERT\* pin. Be careful not to drive a PFI signal externally when it is configured as an output.

As an input, you can individually configure each PFI pin for edge or level detection and for polarity selection, as well. You can use the polarity selection for any of the 13 timing signals, but the edge or level detection will depend upon the particular timing signal being controlled. The

detection requirements for each timing signal are listed within the section that discusses that individual signal.

In edge-detection mode, the minimum pulse width required is 10 ns. This applies for both rising-edge and falling-edge polarity settings. There is no maximum pulse-width requirement in edge-detect mode.

In level-detection mode, there are no minimum or maximum pulse-width requirements imposed by the PFIs themselves, but there may be limits imposed by the particular timing signal being controlled. These requirements are listed later in this chapter.

## DAQ Timing Connections

The DAQ timing signals are SCANCLK, EXTSTROBE\*, TRIG1, TRIG2, STARTSCAN, CONVERT\*, AIGATE, and SISOURCE.

Posttriggered data acquisition allows you to view only data that is acquired after a trigger event is received. A typical posttriggered DAQ sequence is shown in Figure 4-17. Pretriggered data acquisition allows you to view data that is acquired before the trigger of interest in addition to data acquired after the trigger. Figure 4-18 shows a typical pretriggered DAQ sequence. The description for each signal shown in these figures is included later in this chapter.

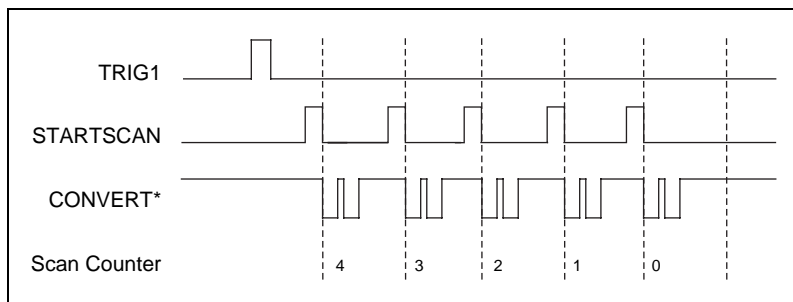

**Figure 4-17.** Typical Posttriggered Acquisition

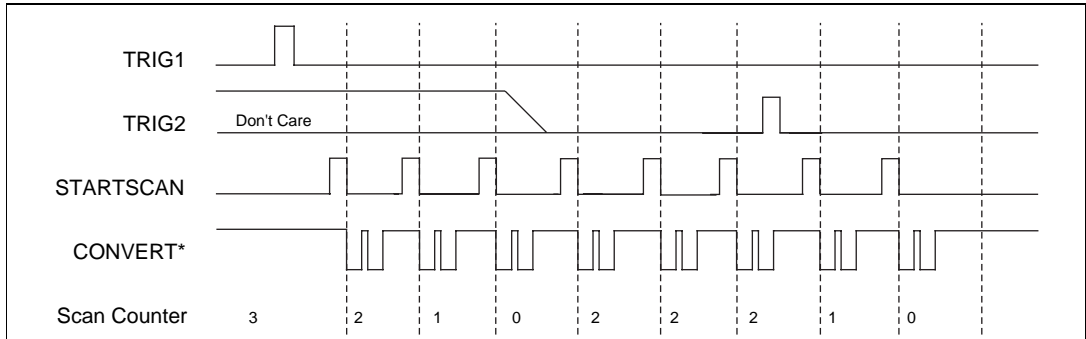

Figure 4-18. Typical Pretriggered Acquisition

## SCANCLK Signal

SCANCLK is an output-only signal that generates a pulse with the leading edge occurring approximately 50 to 100 ns after an A/D conversion begins. The polarity of this output is software-selectable but is typically configured so that a low-to-high leading edge can clock external analog input multiplexers indicating when the input signal has been sampled and can be removed. This signal has a 400 to 500 ns pulse width and is software-enabled. Figure 4-19 shows the timing for the SCANCLK signal.

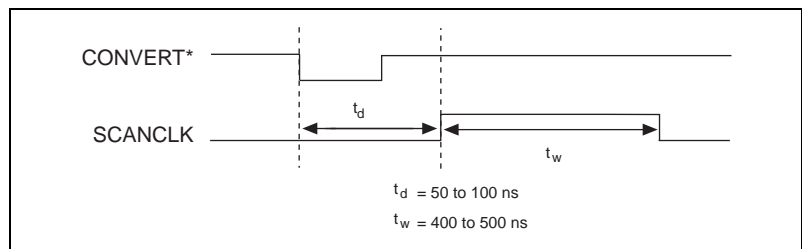
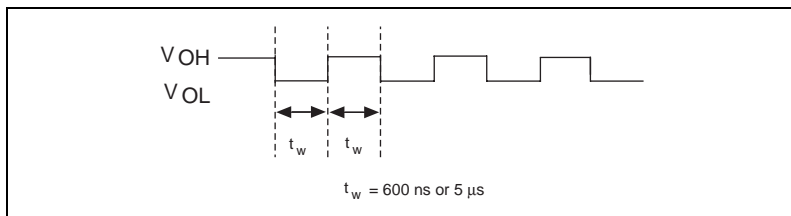

Figure 4-19. SCANCLK Signal Timing

## EXTSTROBE\* Signal

EXTSTROBE\* is an output-only signal that generates either a single pulse or a sequence of eight pulses in the hardware-strobe mode. An external device can use this signal to latch signals or to trigger events. In the single-pulse mode, software controls the level of the EXTSTROBE\* signal. A 10  $\mu$ s and a 1.2  $\mu$ s clock are available for generating a sequence of eight pulses in the hardware-strobe mode. Figure 4-20 shows the timing for the hardware-strobe mode EXTSTROBE\* signal.





**Figure 4-20.** EXTSTROBE\* Signal Timing

## TRIG1 Signal

Any PFI pin can externally input the TRIG1 signal, which is available as an output on the PFI0/TRIG1 pin.

Refer to Figures 4-17 and 4-18 for the relationship of TRIG1 to the DAQ sequence.

As an input, the TRIG1 signal is configured in the edge-detection mode. You can select any PFI pin as the source for TRIG1 and configure the polarity selection for either rising or falling edge. The selected edge of the TRIG1 signal starts the data acquisition sequence for both posttriggered and pretriggered acquisitions.

As an output, the TRIG1 signal reflects the action that initiates a DAQ sequence. This is true even if the acquisition is being externally triggered by another PFI. The output is an active high pulse with a pulse width of 50 to 100 ns. This output is set to tri-state at startup.

Figures 4-21 and 4-22 show the input and output timing requirements for the TRIG1 signal.

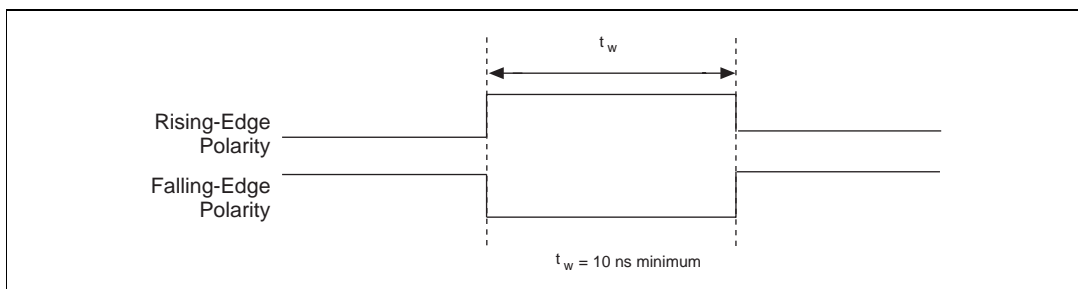

**Figure 4-21.** TRIG1 Input Signal Timing

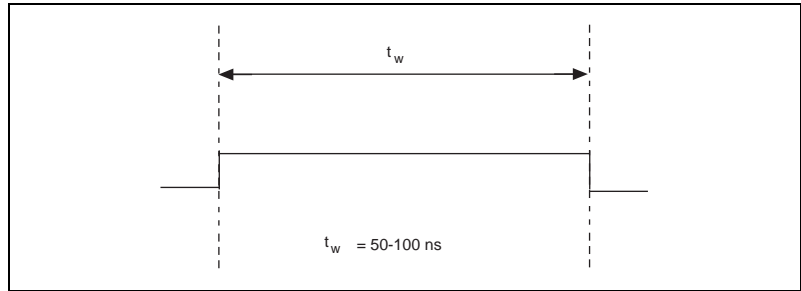

**Figure 4-22.** TRIG1 Output Signal Timing

The board also uses the TRIG1 signal to initiate pretriggered DAQ operations. In most pretriggered applications, the TRIG1 signal is generated by a software trigger. Refer to the TRIG2 signal description for a complete description of the use of TRIG1 and TRIG2 in a pretriggered DAQ operation.

## TRIG2 Signal

Any PFI pin can externally input the TRIG2 signal, which is available as an output on the PFI1/TRIG2 pin. Refer to Figure 4-18 for the relationship of TRIG2 to the DAQ sequence.

As an input, the TRIG2 signal is configured in the edge-detection mode. You can select any PFI pin as the source for TRIG2 and configure the polarity selection for either rising or falling edge. The selected edge of the TRIG2 signal initiates the posttriggered phase of a pretriggered acquisition sequence. In pretriggered mode, the TRIG1 signal initiates the data acquisition. The scan counter indicates the minimum number of scans before TRIG2 can be recognized. After the scan counter decrements to zero, it is loaded with the number of posttrigger scans to acquire while the acquisition continues. The board ignores the TRIG2 signal if it is asserted prior to the scan counter decrementing to zero. After the selected edge of TRIG2 is received, the board will acquire a fixed number of scans and the acquisition will stop. This mode acquires data both before and after receiving TRIG2.

As an output, the TRIG2 signal reflects the posttrigger in a pretriggered acquisition sequence. This is true even if the acquisition is being externally triggered by another PFI. The TRIG2 signal is not used in posttriggered data acquisition. The output is an active high pulse with a pulse width of 50 to 100 ns. This output is set to tri-state at startup.

Figures 4-23 and 4-24 show the input and output timing requirements for the TRIG2 signal.

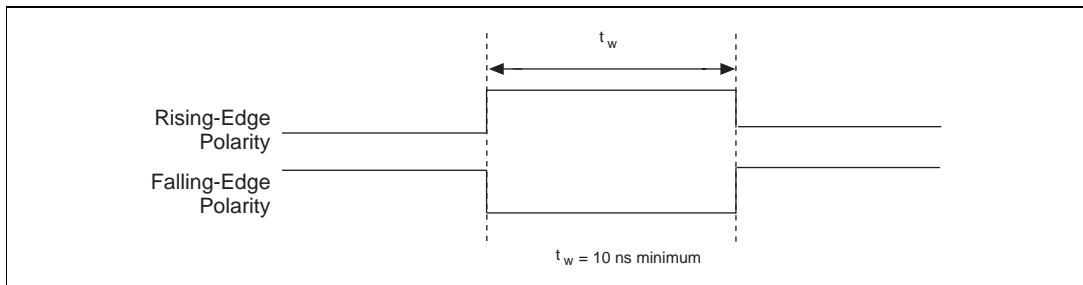

**Figure 4-23.** TRIG2 Input Signal Timing

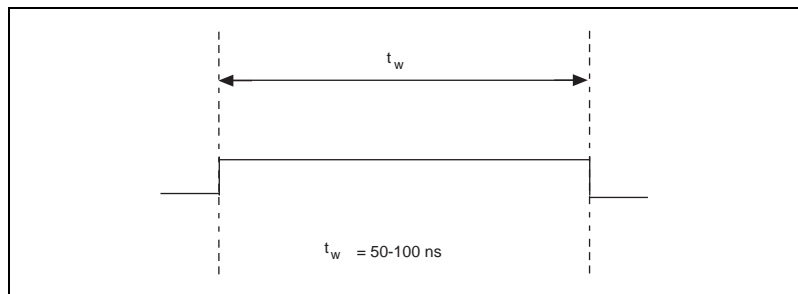

**Figure 4-24.** TRIG2 Output Signal Timing

## STARTSCAN Signal

Any PFI pin can externally input the STARTSCAN signal, which is available as an output on the PFI7/STARTSCAN pin. Refer to Figures 4-17 and 4-18 for the relationship of STARTSCAN to the DAQ sequence.

As an input, the STARTSCAN signal is configured in the edge-detection mode. You can select any PFI pin as the source for STARTSCAN and configure the polarity selection for either rising or falling edge. The selected edge of the STARTSCAN signal initiates a scan. The sample interval counter starts if you select internally triggered CONVERT\*.

As an output, the STARTSCAN signal reflects the actual start pulse that initiates a scan. This is true even if the starts are being externally triggered by another PFI. You have two output options. The first is an active high pulse with a pulse width of 50 to 100 ns, which indicates the start of the scan. The second action is an active high pulse that terminates at the start of the last conversion in the scan, which indicates a scan in progress.

STARTSCAN will be deasserted  $t_{\text{off}}$  after the last conversion in the scan is initiated. This output is set to tri-state at startup.

Figures 4-25 and 4-26 show the input and output timing requirements for the STARTSCAN signal.

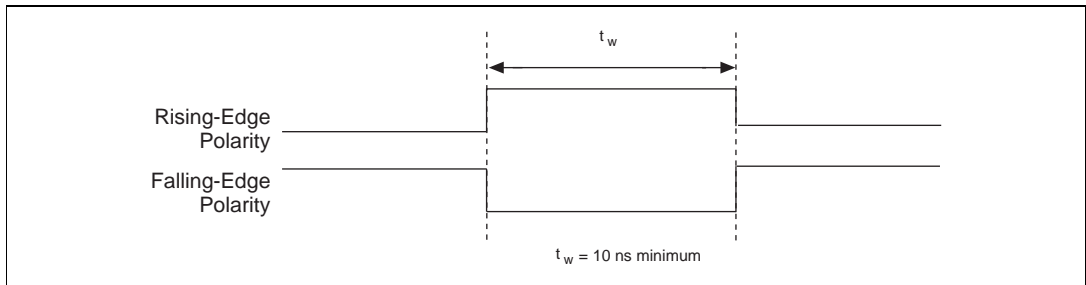

**Figure 4-25.** STARTSCAN Input Signal Timing

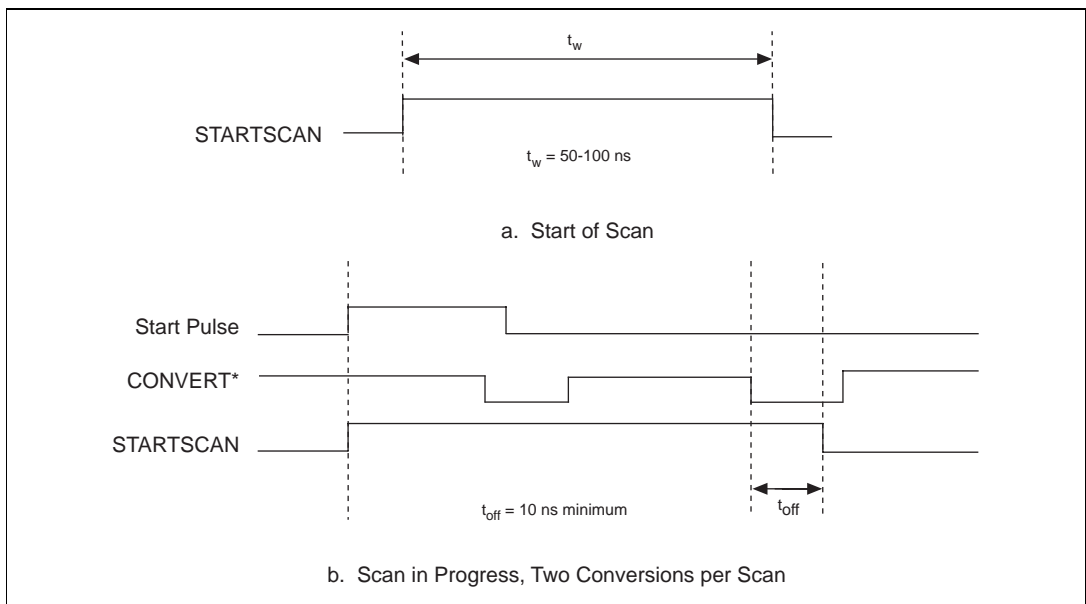

**Figure 4-26.** STARTSCAN Output Signal Timing

The CONVERT\* pulses are masked off until the board generates the STARTSCAN signal. If you are using internally generated conversions, the first CONVERT\* appears when the onboard sample interval counter reaches zero. If you select an external CONVERT\*, the first external pulse after STARTSCAN generates a conversion. The STARTSCAN pulses should be separated by at least one scan period.

A counter on your board internally generates the STARTSCAN signal unless you select some external source. This counter is started by the TRIG1 signal and is stopped either by software or by the sample counter.

Scans generated by either an internal or external STARTSCAN signal are inhibited unless they occur within a DAQ sequence. Scans occurring within a DAQ sequence may be gated by either the hardware (AIGATE) signal or software command register gate.

## CONVERT\* Signal

Any PFI pin can externally input the CONVERT\* signal, which is available as an output on the PFI2/CONVERT\* pin.

Refer to Figures 4-17 and 4-18 for the relationship of CONVERT\* to the DAQ sequence.

As an input, the CONVERT\* signal is configured in the edge-detection mode. You can select any PFI pin as the source for CONVERT\* and configure the polarity selection for either rising or falling edge. The selected edge of the CONVERT\* signal initiates an A/D conversion.

The ADC switches to hold mode within 60 ns of the selected edge. This hold-mode delay time is a function of temperature and does not vary from one conversion to the next. CONVERT\* pulses should be separated by at least 5  $\mu$ s (200 kHz sample rate)

As an output, the CONVERT\* signal reflects the actual convert pulse that is connected to the ADC. This is true even if the conversions are being externally generated by another PFI. The output is an active low pulse with a pulse width of 50 to 150 ns. This output is set to tri-state at startup.

Figures 4-27 and 4-28 show the input and output timing requirements for the CONVERT\* signal.

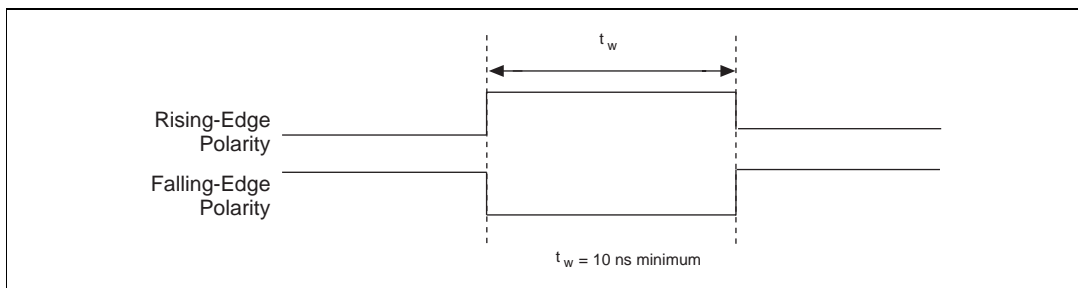

**Figure 4-27.** CONVERT\* Input Signal Timing

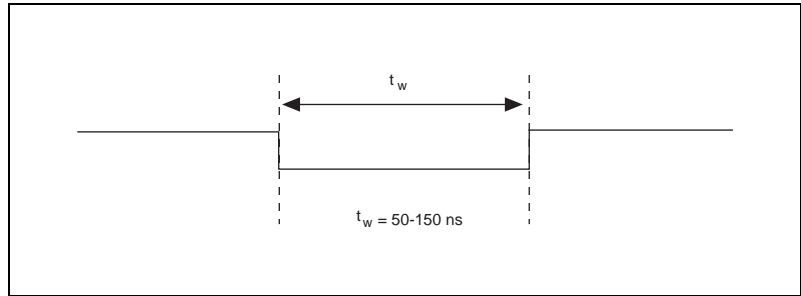

**Figure 4-28.** CONVERT\* Output Signal Timing

The sample interval counter on the board normally generates the CONVERT\* signal unless you select some external source. The counter is started by the STARTSCAN signal and continues to count down and reload itself until the scan is finished. It then reloads itself in preparation for the next STARTSCAN pulse.

A/D conversions generated by either an internal or external CONVERT\* signal are inhibited unless they occur within a DAQ sequence. Scans occurring within a DAQ sequence may be gated by either the hardware (AIGATE) signal or software command register gate.

## AIGATE Signal

Any PFI pin can externally input the AIGATE signal, which is not available as an output on the I/O connector. The AIGATE signal can mask off scans in a DAQ sequence. You can configure the PFI pin you select as the source for the AIGATE signal in either the level-detection or edge-detection mode. You can configure the polarity selection for the PFI pin for either active high or active low.

In the level-detection mode if AIGATE is active, the STARTSCAN signal is masked off and no scans can occur. In the edge-detection mode, the first active edge disables the STARTSCAN signal, and the second active edge enables STARTSCAN.

The AIGATE signal can neither stop a scan in progress nor continue a previously gated-off scan; in other words, once a scan has started, AIGATE does not gate off conversions until the beginning of the next scan and, conversely, if conversions are being gated off, AIGATE does not gate them back on until the beginning of the next scan.

## SISOURCE Signal

Any PFI pin can externally input the SISOURCE signal, which is not available as an output on the I/O connector. The onboard scan interval counter uses the SISOURCE signal as a clock to time the generation of the STARTSCAN signal. You must configure the PFI pin you select as the source for the SISOURCE signal in the level-detection mode. You can configure the polarity selection for the PFI pin for either active high or active low.

The maximum allowed frequency is 20 MHz, with a minimum pulse width of 23 ns high or low. There is no minimum frequency limitation.

Either the 20 MHz or 100 kHz internal timebase generates the SISOURCE signal unless you select some external source. Figure 4-29 shows the timing requirements for the SISOURCE signal.

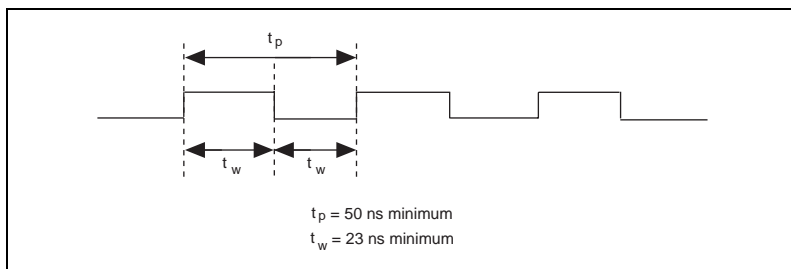

Figure 4-29. SISOURCE Signal Timing

## Waveform Generation Timing Connections

The analog group defined for your board is controlled by WFTRIG, UPDATE\*, and UISOURCE.

### WFTRIG Signal

Any PFI pin can externally input the WFTRIG signal, which is available as an output on the PFI6/WFTRIG pin.

As an input, the WFTRIG signal is configured in the edge-detection mode. You can select any PFI pin as the source for WFTRIG and configure the polarity selection for either rising or falling edge. The selected edge of the WFTRIG signal starts the waveform generation for the DACs. The update interval (UI) counter is started if you select internally generated UPDATE\*.

As an output, the WFTRIG signal reflects the trigger that initiates waveform generation. This is true even if the waveform generation is being

externally triggered by another PFI. The output is an active high pulse with a pulse width of 50 to 100 ns. This output is set to tri-state at startup.

Figures 4-30 and 4-31 show the input and output timing requirements for the WFTRIG signal.

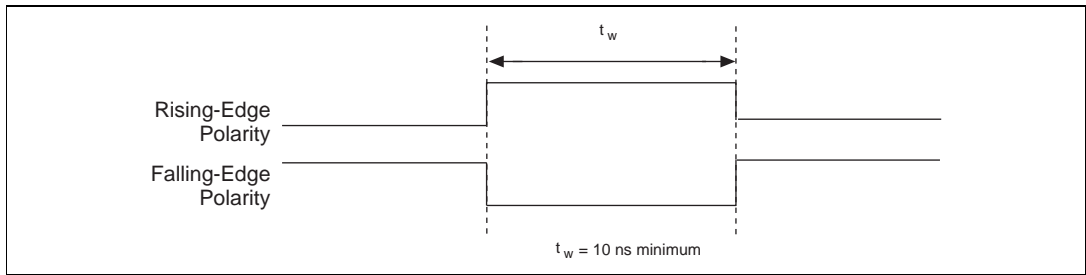

**Figure 4-30.** WFTRIG Input Signal Timing

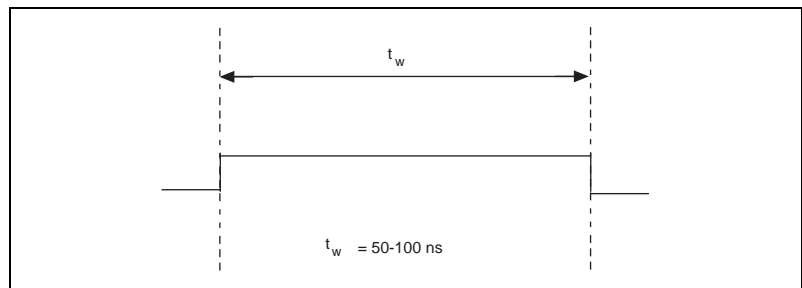

**Figure 4-31.** WFTRIG Output Signal Timing

## UPDATE\* Signal

Any PFI pin can externally input the UPDATE\* signal, which is available as an output on the PFI5/UPDATE\* pin.

As an input, the UPDATE\* signal is configured in the edge-detection mode. You can select any PFI pin as the source for UPDATE\* and configure the polarity selection for either rising or falling edge. The selected edge of the UPDATE\* signal updates the outputs of the DACs. In order to use UPDATE\*, you must set the DACs to posted-update mode.

As an output, the UPDATE\* signal reflects the actual update pulse that is connected to the DACs. This is true even if the updates are being externally generated by another PFI. The output is an active low pulse with a pulse width of 300 to 350 ns. This output is set to tri-state at startup.



Figures 4-32 and 4-33 show the input and output timing requirements for the UPDATE\* signal.

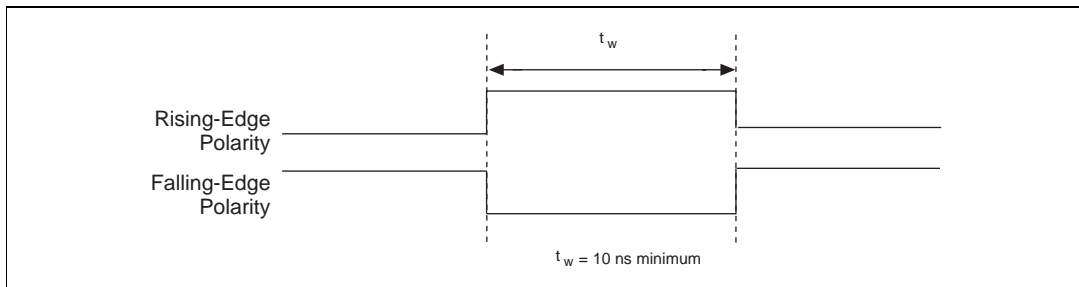

**Figure 4-32.** UPDATE\* Input Signal Timing

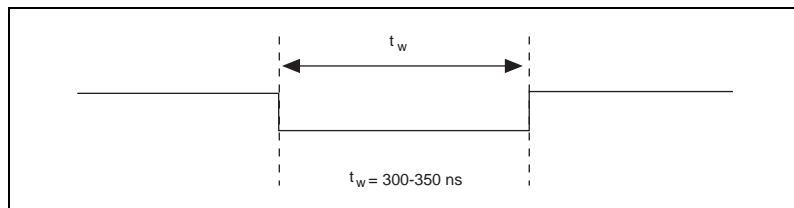

**Figure 4-33.** UPDATE\* Output Signal Timing

The DACs are updated within 100 ns of the leading edge. Separate the UPDATE\* pulses with enough time that new data can be written to the DAC latches.

The board UI counter normally generates the UPDATE\* signal unless you select some external source. The UI counter is started by the WFTRIG signal and can be stopped by software or the internal Buffer Counter.

D/A conversions generated by either an internal or external UPDATE\* signal do not occur when gated by the software command register gate.

## UISOURCE Signal

Any PFI pin can externally input the UISOURCE signal, which is not available as an output on the I/O connector. The UI counter uses the UISOURCE signal as a clock to time the generation of the UPDATE\* signal. You must configure the PFI pin you select as the source for the UISOURCE signal in the level-detection mode. You can configure the polarity selection for the PFI pin for either active high or active low. Figure 4-34 shows the timing requirements for the UISOURCE signal.

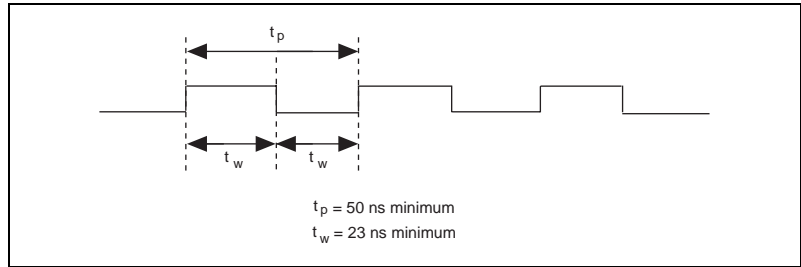

**Figure 4-34.** UISOURCE Signal Timing

The maximum allowed frequency is 20 MHz, with a minimum pulse width of 23 ns high or low. There is no minimum frequency limitation.

Either the 20 MHz or 100 kHz internal timebase normally generates the UISOURCE signal unless you select some external source.

## General-Purpose Timing Signal Connections

The general-purpose timing signals are GPCTR0\_SOURCE, GPCTR0\_GATE, GPCTR0\_OUT, GPCTR0\_UP\_DOWN, GPCTR1\_SOURCE, GPCTR1\_GATE, GPCTR1\_OUT, GPCTR1\_UP\_DOWN, and FREQ\_OUT.

### GPCTR0\_SOURCE Signal

Any PFI pin can externally input the GPCTR0\_SOURCE signal, which is available as an output on the PFI8/GPCTR0\_SOURCE pin.

As an input, the GPCTR0\_SOURCE signal is configured in the edge-detection mode. You can select any PFI pin as the source for GPCTR0\_SOURCE and configure the polarity selection for either rising or falling edge.

As an output, the GPCTR0\_SOURCE signal reflects the actual clock connected to general-purpose counter 0. This is true even if another PFI is externally inputting the source clock. This output is set to tri-state at startup.

Figure 4-35 shows the timing requirements for the GPCTR0\_SOURCE signal.

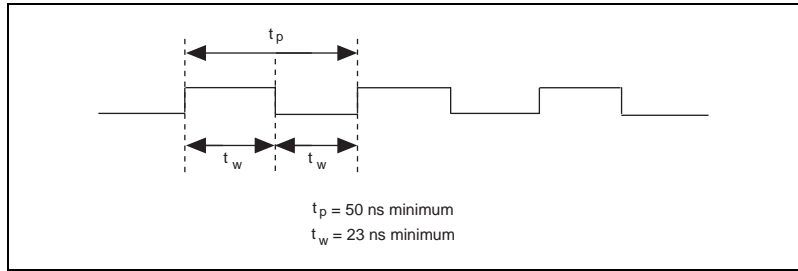

**Figure 4-35.** GPCTRO\_SOURCE Signal Timing

The maximum allowed frequency is 20 MHz, with a minimum pulse width of 23 ns high or low. There is no minimum frequency limitation.

The 20 MHz or 100 kHz timebase normally generates the GPCTRO\_SOURCE signal unless you select some external source.

### GPCTRO\_GATE Signal

Any PFI pin can externally input the GPCTRO\_GATE signal, which is available as an output on the PFI9/GPCTRO\_GATE pin.

As an input, the GPCTRO\_GATE signal is configured in the edge-detection mode. You can select any PFI pin as the source for GPCTRO\_GATE and configure the polarity selection for either rising or falling edge. You can use the gate signal in a variety of different applications to perform actions such as starting and stopping the counter, generating interrupts, saving the counter contents, and so on.

As an output, the GPCTRO\_GATE signal reflects the actual gate signal connected to general-purpose counter 0. This is true even if the gate is being externally generated by another PFI. This output is set to tri-state at startup. Figure 4-36 shows the timing requirements for the GPCTRO\_GATE signal.

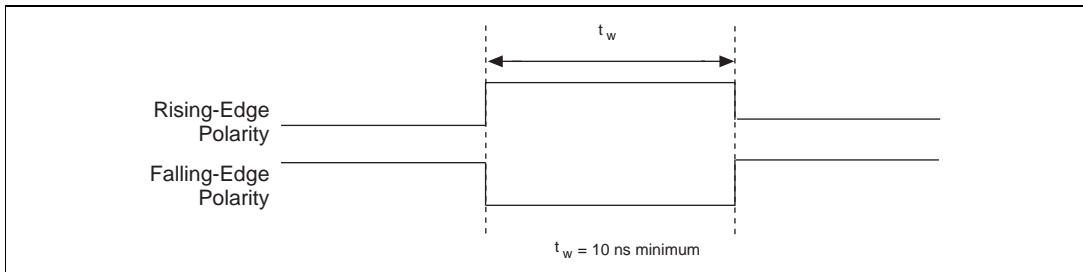

**Figure 4-36.** GPCTRO\_GATE Signal Timing in Edge-Detection Mode

## GPCTRO\_OUT Signal

This signal is available only as an output on the GPCTRO\_OUT pin. The GPCTRO\_OUT signal reflects the terminal count (TC) of general-purpose counter 0. You have two software-selectable output options—pulse on TC and toggle output polarity on TC. The output polarity is software-selectable for both options. This output is set to tri-state at startup. Figure 4-37 shows the timing of the GPCTRO\_OUT signal.

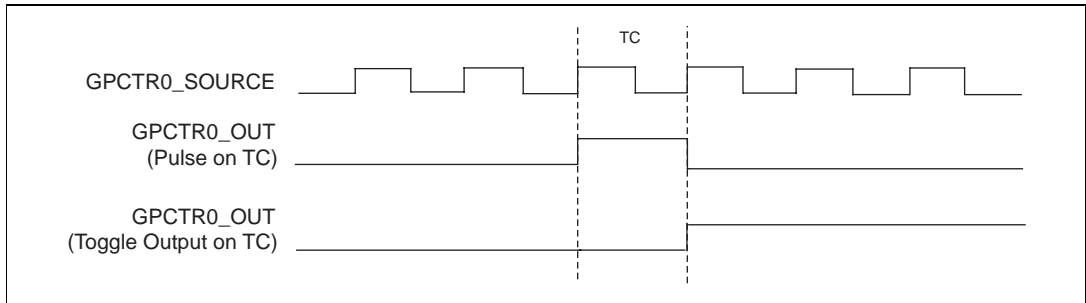

Figure 4-37. GPCTRO\_OUT Signal Timing

## GPCTRO\_UP\_DOWN Signal

This signal can be externally input on the DIO6 pin and is not available as an output on the I/O connector. The general-purpose counter 0 will count down when this pin is at a logic low and count up when it is at a logic high. You can disable this input so that software can control the up-down functionality and leave the DIO6 pin free for general use.

## GPCTR1\_SOURCE Signal

Any PFI pin can externally input the GPCTR1\_SOURCE signal, which is available as an output on the PFI3/GPCTR1\_SOURCE pin.

As an input, the GPCTR1\_SOURCE signal is configured in the edge-detection mode. You can select any PFI pin as the source for GPCTR1\_SOURCE and configure the polarity selection for either rising or falling edge.

As an output, the GPCTR1\_SOURCE monitors the actual clock connected to general-purpose counter 1. This is true even if the source clock is being externally generated by another PFI. This output is set to tri-state at startup.

Figure 4-38 shows the timing requirements for the GPCTR1\_SOURCE signal.

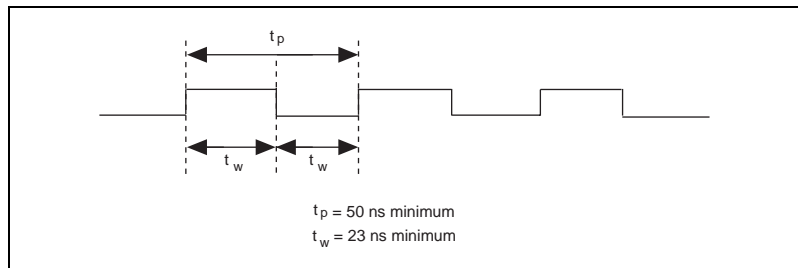

**Figure 4-38.** GPCTR1\_SOURCE Signal Timing

The maximum allowed frequency is 20 MHz, with a minimum pulse width of 23 ns high or low. There is no minimum frequency limitation.

The 20 MHz or 100 kHz timebase normally generates the GPCTR1\_SOURCE unless you select some external source.

## GPCTR1\_GATE Signal

Any PFI pin can externally input the GPCTR1\_GATE signal, which is available as an output on the PFI4/GPCTR1\_GATE pin.

As an input, the GPCTR1\_GATE signal is configured in edge-detection mode. You can select any PFI pin as the source for GPCTR1\_GATE and configure the polarity selection for either rising or falling edge. You can use the gate signal in a variety of different applications to perform such actions as starting and stopping the counter, generating interrupts, saving the counter contents, and so on.

As an output, the GPCTR1\_GATE signal monitors the actual gate signal connected to general-purpose counter 1. This is true even if the gate is being externally generated by another PFI. This output is set to tri-state at startup.

Figure 4-39 shows the timing requirements for the GPCTR1\_GATE signal.

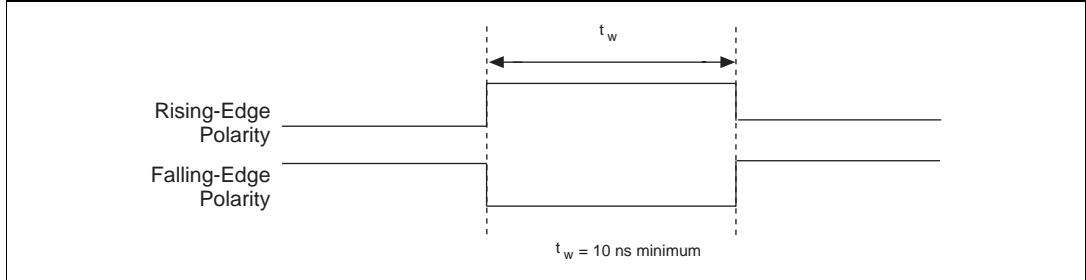

**Figure 4-39.** GPCTR1\_GATE Signal Timing in Edge-Detection Mode

## GPCTR1\_OUT Signal

This signal is available only as an output on the GPCTR1\_OUT pin. The GPCTR1\_OUT signal monitors the TC board general-purpose counter 1. You have two software-selectable output options—pulse on TC and toggle output polarity on TC. The output polarity is software-selectable for both options. This output is set to tri-state at startup. Figure 4-40 shows the timing requirements for the GPCTR1\_OUT signal.

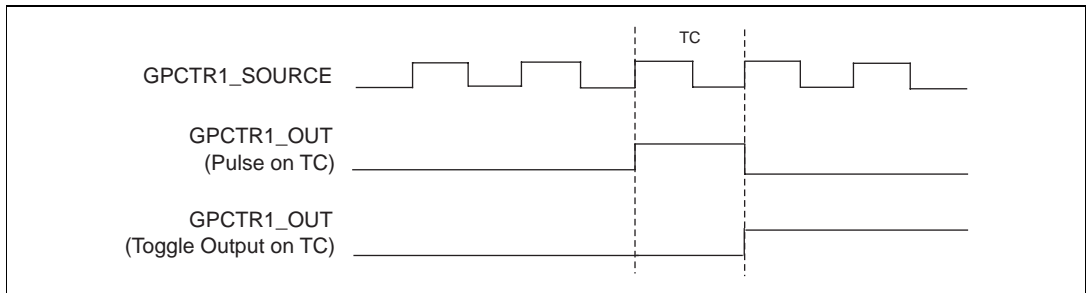

**Figure 4-40.** GPCTR1\_OUT Signal Timing

## GPCTR1\_UP\_DOWN Signal

This signal can be externally input on the DIO7 pin and is not available as an output on the I/O connector. General-purpose counter 1 counts down when this pin is at a logic low and counts up at a logic high. This input can be disabled so that software can control the up-down functionality and leave the DIO7 pin free for general use. Figure 4-41 shows the timing requirements for the GATE and SOURCE input signals and the timing specifications for the OUT output signals of your board.

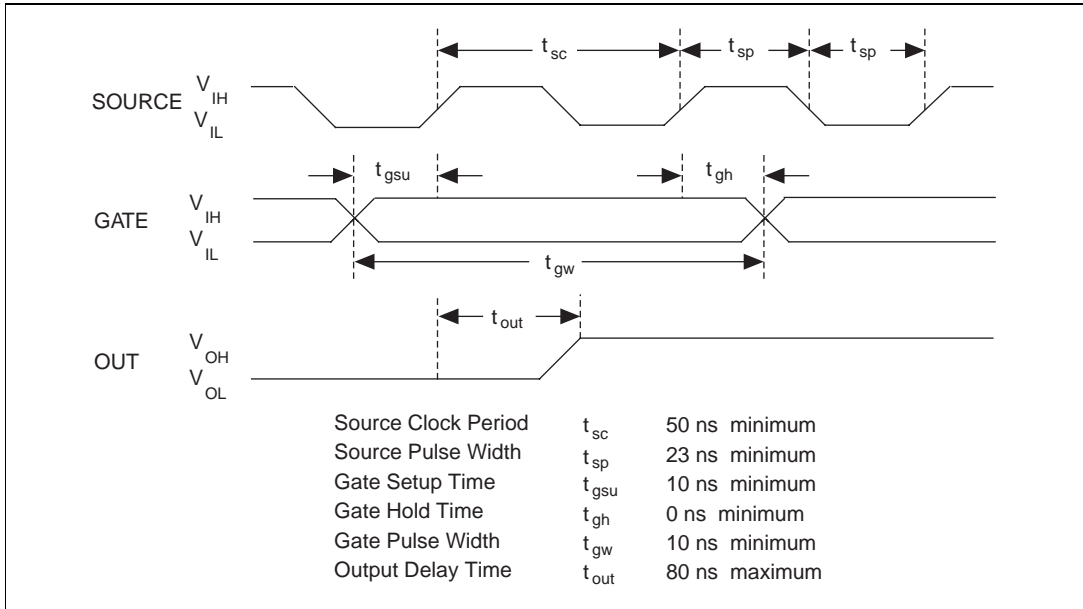

**Figure 4-41.** GPCTR Timing Summary

The GATE and OUT signal transitions shown in Figure 4-41 are referenced to the rising edge of the SOURCE signal. This timing diagram assumes that the counters are programmed to count rising edges. The same timing diagram, but with the source signal inverted and referenced to the falling edge of the source signal, would apply when the counter is programmed to count falling edges.

The GATE input timing parameters are referenced to the signal at the SOURCE input or to one of the internally generated signals on your board. Figure 4-41 shows the GATE signal referenced to the rising edge of a source signal. The gate must be valid (either high or low) for at least 10 ns before the rising or falling edge of a source signal for the gate to take effect at that source edge, as shown by  $t_{gsu}$  and  $t_{gh}$  in Figure 4-41. The gate signal is not required to be held after the active edge of the source signal.

If you use an internal timebase clock, the gate signal cannot be synchronized with the clock. In this case, gates applied close to a source edge take effect either on that source edge or on the next one. This arrangement results in an uncertainty of one source clock period with respect to unsynchronized gating sources.

The OUT output timing parameters are referenced to the signal at the SOURCE input or to one of the internally generated clock signals on the

boards. Figure 4-41 shows the OUT signal referenced to the rising edge of a source signal. Any OUT signal state changes occur within 80 ns after the rising or falling edge of the source signal.

## FREQ\_OUT Signal

This signal is available only as an output on the FREQ\_OUT pin. The board's frequency generator outputs the FREQ\_OUT pin. The frequency generator is a 4-bit counter that can divide its input clock by the numbers 1 through 16. The input clock of the frequency generator is software-selectable from the internal 10 MHz and 100 kHz timebases. The output polarity is software-selectable. This output is set to tri-state at startup.

# Field Wiring Considerations

---

Environmental noise can seriously affect the accuracy of measurements made with your board if you do not take proper care when running signal wires between signal sources and the board. The following recommendations apply mainly to analog input signal routing to the board, although they also apply to signal routing in general.

Minimize noise pickup and maximize measurement accuracy by taking the following precautions:

- Use differential analog input connections to reject common-mode noise.
- Use individually shielded, twisted-pair wires to connect analog input signals to the board. With this type of wire, the signals attached to the CH+ and CH- inputs are twisted together and then covered with a shield. You then connect this shield only at one point to the signal source ground. This kind of connection is required for signals traveling through areas with large magnetic fields or high electromagnetic interference.
- Route signals to the board carefully. Keep cabling away from noise sources. The most common noise source in a computer based data acquisition system is the video monitor. Separate the monitor from the analog signals as much as possible.

The following recommendations apply for all signal connections to your board:

- Separate board signal lines from high-current or high-voltage lines. These lines can induce currents in or voltages on the board signal lines



if they run in parallel paths at a close distance. To reduce the magnetic coupling between lines, separate them by a reasonable distance if they run in parallel, or run the lines at right angles to each other.

- Do not run signal lines through conduits that also contain power lines.
- Protect signal lines from magnetic fields caused by electric motors, welding equipment, breakers, or transformers by running them through special metal conduits.

For more information, refer to the application note, *Field Wiring and Noise Consideration for Analog Signals*, available from National Instruments.

---

# Calibration

This chapter discusses the calibration procedures for your board. If you are using the NI-DAQ device driver, that software includes calibration functions for performing all of the steps in the calibration process.

Calibration refers to the process of minimizing measurement and output voltage errors by making small circuit adjustments. For these boards, these adjustments take the form of writing values to onboard calibration DACs (CalDACs).

Some form of board calibration is required for all but the most forgiving applications. If you do not calibrate your board, your signals and measurements could have very large offset, gain, and linearity errors.

Three levels of calibration are available to you and described in this chapter. The first level is the fastest, easiest, and least accurate, whereas the last level is the slowest, most difficult, and most accurate.

---

## Loading Calibration Constants

Your board is factory calibrated before shipment at approximately 25 °C to the levels indicated in Appendix A, *Specifications*. The associated calibration constants—the values that were written to the CalDACs to achieve calibration in the factory—are stored in the onboard nonvolatile memory (EEPROM). Because the CalDACs have no memory capability, they do not retain calibration information when the board is unpowered. Loading calibration constants refers to the process of loading the CalDACs with the values stored in the EEPROM. NI-DAQ software determines when this is necessary and does it automatically. If you are not using NI-DAQ, you must load these values yourself.

In the EEPROM there is a user-modifiable calibration area in addition to the permanent factory calibration area. This means that you can load the CalDACs with values either from the original factory calibration or from a calibration that you subsequently performed.

This method of calibration is not very accurate because it does not take into account the fact that the board measurement and output voltage errors can

vary with time and temperature. It is better to self-calibrate when the board is installed in the environment in which it will be used.

## Self-Calibration

---

Your board can measure and correct for almost all of its calibration-related errors without any external signal connections. Your National Instruments software provides a self-calibration method. This self-calibration process, which generally takes less than a minute, is the preferred method of assuring accuracy in your application. Initiate self-calibration to minimize the effects of any offset, gain, and linearity drifts, particularly those due to warmup.

Immediately after self-calibration, the only significant residual calibration error could be gain error due to time or temperature drift of the onboard voltage reference. This error is addressed by external calibration, which is discussed in the following section. If you are interested primarily in relative measurements, you can ignore a small amount of gain error, and self-calibration should be sufficient.

## External Calibration

---

Your board has an onboard calibration reference to ensure the accuracy of self-calibration. Its specifications are listed in Appendix A, *Specifications*. The reference voltage is measured at the factory and stored in the EEPROM for subsequent self-calibrations. This voltage is stable enough for most applications, but if you are using your board at an extreme temperature or if the onboard reference has not been measured for a year or more, you may wish to externally calibrate your board.

An external calibration refers to calibrating your board with a known external reference rather than relying on the onboard reference. Redetermining the value of the onboard reference is part of this process and the results can be saved in the EEPROM, so you should not have to perform an external calibration very often. You can externally calibrate your board by calling the NI-DAQ calibration function.

To externally calibrate your board, be sure to use a very accurate external reference. The reference should be several times more accurate than the board itself.

## Other Considerations

---

The CalDACs adjust the gain error of each analog output channel by adjusting the value of the reference voltage supplied to that channel. This calibration mechanism is designed to work only with the internal 10 V reference. Thus, in general, it is not possible to calibrate the analog output gain error when using an external reference. In this case, it is advisable to account for the nominal gain error of the analog output channel either in software or with external hardware. See Appendix A, [Specifications](#), for analog output gain error information.

## Specifications

This appendix lists the specifications of 6023E, 6024E, and 6025E boards. These specifications are typical at 25 °C unless otherwise noted.

### Analog Input

#### Input Characteristics

Number of channels ..... 16 single-ended or 8 differential  
(software-selectable per channel)

Type of ADC..... Successive approximation

Resolution ..... 12 bits, 1 in 4,096

Sampling rate ..... 200 kS/s guaranteed

Input signal ranges ..... Bipolar only

<b>Board Gain (Software-Selectable)</b>	<b>Range</b>
0.5	±10 V
1	±5 V
10	±500 mV
100	±50 mV

Input coupling ..... DC

Max working voltage  
(signal + common mode) ..... Each input should remain within  
±11 V of ground

Overvoltage protection

	Powered On	Powered Off
ACH<0..15>	±42	±35
AISENSE	±40	±25

FIFO buffer size.....512 S

Data transfers .....DMA, interrupts,  
programmed I/O

DMA modes .....Scatter-gather  
(Single transfer, demand transfer)

Configuration memory size .....512 words

### Accuracy Information

Nominal Range (V)		Absolute Accuracy							Relative Accuracy	
		% of Reading			Offset	Noise + Quantization (mV)		Temp Drift	Resolution (mV)	
Positive FS	Negative FS	24 Hours	90 Days	1 Year	(mV)	Single Pt.	Averaged	(%/ °C)	Theoretical	Averaged
10	-10	0.0722	0.0742	0.0764	±6.385	± 3.906	±0.975	0.0010	4.883	1.284
5	-5	0.0272	0.0292	0.0314	±3.203	± 1.953	±0.488	0.0005	2.441	0.642
0.5	-0.5	0.0722	0.0742	0.0764	±0.340	± 0.195	±0.049	0.0010	0.244	0.064
0.05	-0.05	0.0722	0.0742	0.0764	±0.054	± 0.063	±0.006	0.0010	0.024	0.008

**Note:** Accuracies are valid for measurements following an internal E Series calibration. Averaged numbers assume dithering and averaging of 100 single-channel readings. Measurement accuracies are listed for operational temperatures within ± 1 °C of internal calibration temperature and ±10 °C of external or factory calibration temperature.

## Transfer Characteristics

Relative accuracy .....	$\pm 0.5$ LSB typ dithered, $\pm 1.5$ LSB max undithered
DNL .....	$\pm 0.5$ LSB typ, $\pm 1.0$ LSB max
No missing codes .....	12 bits, guaranteed
Offset error	
Pregain error after calibration .....	$\pm 12$ $\mu$ V max
Pregain error before calibration .....	$\pm 28$ mV max
Postgain error after calibration .....	$\pm 0.5$ mV max
Postgain error before calibration.....	$\pm 100$ mV max
Gain error (relative to calibration reference)	
After calibration (gain = 1) .....	$\pm 0.02\%$ of reading max
Before calibration .....	$\pm 2.75\%$ of reading max
Gain $\neq 1$ with gain error adjusted to 0 at gain = 1 .....	$\pm 0.05\%$ of reading max

## Amplifier Characteristics

Input impedance	
Normal powered on .....	100 G $\Omega$ in parallel with 100 pF
Powered off .....	4 k $\Omega$ min
Overload.....	4 k $\Omega$ min
Input bias current .....	$\pm 200$ pA
Input offset current.....	$\pm 100$ pA
CMRR (DC to 60 Hz)	
Gain 0.5, 1.0.....	85 dB
Gain 10, 100.....	90 dB

## Dynamic Characteristics

Bandwidth

Signal	Bandwidth
Small (-3 dB)	500 kHz
Large (1% THD)	225 kHz

Settling time for full-scale step.....5  $\mu$ s max to  $\pm 1.0$  LSB accuracy

System noise (LSBrms, not including quantization)

Gain	Dither Off	Dither On
0.5 to 10	0.1	0.6
100	0.7	0.8

Crosstalk .....-60 dB, DC to 100 kHz

## Stability

Recommended warm-up time.....15 min.

Offset temperature coefficient

Pregain..... $\pm 15 \mu\text{V}/^\circ\text{C}$

Postgain ..... $\pm 240 \mu\text{V}/^\circ\text{C}$

Gain temperature coefficient ..... $\pm 20 \text{ ppm}/^\circ\text{C}$

## Analog Output

- ◆ 6024E and 6025E only

## Output Characteristics

Number of channels.....2 voltage

Resolution.....12 bits, 1 in 4,096



Max update rate  
 DMA ..... 10 kHz, system dependent  
 Interrupts ..... 1 kHz, system dependent  
 Type of DAC ..... Double buffered, multiplying  
 FIFO buffer size ..... none  
 Data transfers ..... DMA, interrupts, programmed I/O  
 DMA modes ..... Scatter-gather  
 (Single transfer, demand transfer)

## Accuracy Information

Nominal Range (V)		Absolute Accuracy				
		% of Reading			Offset	Temp Drift
Positive FS	Negative FS	24 Hours	90 Days	1 Year	(mV)	(%/ °C)
10	-10	0.0177	0.0197	0.0219	± 5.933	0.0005

## Transfer Characteristics

### Relative accuracy (INL)

After calibration ..... ±0.3 LSB typ, ±0.5 LSB max  
 Before calibration ..... ±4 LSB max

### DNL

After calibration ..... ±0.3 LSB typ, ± 1.0 LSB max  
 Before calibration ..... ±3 LSB max

Monotonicity ..... 12 bits, guaranteed after calibration

### Offset error

After calibration ..... ±1.0 mV max  
 Before calibration ..... ±200 mV max

Gain error (relative to internal reference)  
 After calibration..... $\pm 0.01\%$  of output max  
 Before calibration ..... $\pm 0.75\%$  of output max

## Voltage Output

Range ..... $\pm 10$  V  
 Output coupling .....DC  
 Output impedance..... $0.1 \Omega$  max  
 Current drive..... $\pm 5$  mA max  
 Protection.....Short-circuit to ground  
 Power-on state (steady state) ..... $\pm 200$  mV  
 Initial power-up glitch  
     Magnitude..... $\pm 1.1$  V  
     Duration.....  $2.0$  ms  
 Power reset glitch  
     Magnitude..... $\pm 2.2$  V  
     Duration.....  $4.2 \mu\text{s}$

## Dynamic Characteristics

Settling time for full-scale step.....  $10 \mu\text{s}$  to  $\pm 0.5$  LSB accuracy  
 Slew rate .....  $10$  V/ $\mu\text{s}$   
 Noise .....  $200 \mu\text{V}_{\text{rms}}$ , DC to  $1$  MHz  
 Midscale transition glitch  
     Magnitude..... $\pm 12$  mV  
     Duration.....  $2.0 \mu\text{s}$

## Stability

Offset temperature coefficient ..... $\pm 50 \mu\text{V}/^\circ\text{C}$   
 Gain temperature coefficient ..... $\pm 25$  ppm/ $^\circ\text{C}$

## Digital I/O

Number of channels	
6025E .....	32 input/output
6023E and 6024E.....	8 input/output
Compatibility .....	TTL/CMOS

### DIO<0..7>

Digital logic levels

Level	Min	Max
Input low voltage	0 V	0.8 V
Input high voltage	2 V	5 V
Input low current ( $V_{in} = 0$ V)	—	-320 $\mu$ A
Input high current ( $V_{in} = 5$ V)	—	10 $\mu$ A
Output low voltage ( $I_{OL} = 24$ mA)	—	0.4 V
Output high voltage ( $I_{OH} = 13$ mA)	4.35 V	—

Power-on state ..... Input (High-Z),  
50 k $\Omega$  pull up to +5 VDC

Data transfers ..... Programmed I/O

### PA<0..7>,PB<0..7>,PC<0..7>

- ◆ 6025E only

Digital logic levels

Level	Min	Max
Input low voltage	0 V	0.8 V
Input high voltage	2.2 V	5 V
Input low current ( $V_{in} = 0$ V, 100 k $\Omega$ pull up)	—	-75 $\mu$ A
Input high current ( $V_{in} = 5$ V, 100 k $\Omega$ pull up)	—	10 $\mu$ A
Output low voltage ( $I_{OL} = 2.5$ mA)	—	0.4 V
Output high voltage ( $I_{OH} = 2.5$ mA)	3.7 V	—

Handshaking .....	2-wire
Power-on state	
PA<0..7>.....	Input (High-Z), 100 kΩ pull-up to +5 VDC
PB<0..7>.....	Input (High-Z), 100 kΩ pull-up to +5 VDC
PC<0..7>.....	Input (High-Z), 100 kΩ pull-up to +5 VDC
Data transfers .....	Interrupts, programmed I/O

## Timing I/O

Number of channels .....	2 up/down counter/timers, 1 frequency scaler
Resolution .....	
Counter/timers .....	24 bits
Frequency scalars .....	4 bits
Compatibility .....	TTL/CMOS
Base clocks available	
Counter/timers .....	20 MHz, 100 kHz
Frequency scalars .....	10 MHz, 100 kHz
Base clock accuracy.....	±0.01%
Max source frequency.....	20 MHz
Min source pulse duration .....	10 ns in edge-detect mode
Min gate pulse duration .....	10 ns in edge-detect mode
Data transfers .....	DMA, interrupts, programmed I/O
DMA modes .....	Scatter-gather (Single transfer, demand transfer)

## Triggers

### Digital Trigger

Compatibility .....	TTL
Response .....	Rising or falling edge
Pulse width .....	10 ns min

### RTSI

Trigger lines .....	7
---------------------	---

## Calibration

Recommended warm-up time .....	15 minutes
Interval .....	1 year
External Calibration reference .....	> 6 and < 10 V
Onboard calibration reference	
Level .....	5.000 V ( $\pm 3.5$ mV) (actual value stored in EEPROM)
Temperature coefficient .....	$\pm 5$ ppm/ $^{\circ}$ C max
Long-term stability .....	$\pm 15$ ppm/ $\sqrt{1,000}$ h

## Power Requirement

+5 VDC ( $\pm 5\%$ ) .....	0.7 A
----------------------------	-------



**Note** *Excludes power consumed through  $V_{cc}$  available at the I/O connector.*

Power available at I/O connector .....	+4.65 to +5.25 VDC at 1 A
----------------------------------------	---------------------------

## Physical

Dimensions (not including connectors)	
PCI boards .....	17.5 by 10.6 cm (6.9 by 4.2 in.)
PXI boards .....	16.0 by 10.0 cm (6.3 by 3.9 in.)
I/O connector	
6023E/6024E .....	68-pin male SCSI-II type

6025E.....100-pin female 0.05D type

## Operating Environment

Ambient temperature .....0 to 55 °C

Relative humidity .....10% to 90% noncondensing

- ◆ PXI-6025E only

Functional Shock .....MIL-T-28800 E Class 3 (per Section 4.5.5.4.1) Half-sine shock pulse, 11 ms duration, 30 g peak, 30 shocks per face

Operational random vibration.....5 to 500 Hz, 0.31 g<sub>rms</sub>, 3 axes

## Storage Environment

Ambient temperature .....-20 to 70 °C

Relative humidity .....5% to 95% noncondensing

- ◆ PXI-6025E only

Non-operational random vibration .....5 to 500 Hz, 2.5 g<sub>rms</sub>, 3 axes



### Note

***Random vibration profiles were developed in accordance with MIL-T-28800E and MIL-STD-810E Method 514. Test levels exceed those recommended in MIL-STD-810E for Category 1, Basic Transportation.***

---

## Custom Cabling and Optional Connectors

This appendix describes the various cabling and connector options for the boards.

### Custom Cabling

---

National Instruments offers cables and accessories for you to prototype your application or to use if you frequently change board interconnections.

If you want to develop your own cable, however, the following guidelines may be useful:

- For the analog input signals, shielded twisted-pair wires for each analog input pair yield the best results, assuming that you use differential inputs. Tie the shield for each signal pair to the ground reference at the source.
- You should route the analog lines separately from the digital lines.
- When using a cable shield, use separate shields for the analog and digital halves of the cable. Failure to do so results in noise coupling into the analog signals from transient digital signals.

The following list gives recommended part numbers for connectors that mate to the I/O connector on your board.

Mating connectors and a backshell kit for making custom 68-pin cables are available from National Instruments (part number 776832-01)

- ◆ 6023E and 6024E

Honda 68-position, solder cup, female connector  
(part number PCS-E68FS)

Honda backshell (part number PCS-E68LKPA)

- ◆ 6025E
  - AMP 100-position IDC male connector (part number 1-750913-9)
  - AMP backshell, 0.50 max O.D. cable (part number 749081-1)
  - AMP backshell, 0.55 max O.D. cable, (part number 749854-1)

## Optional Connectors

---

Figure B-1 shows the pin assignments for the 68-pin E Series connector. This connector is available when you use the SH6868 or R6868 cable assemblies with the 6023E and 6024E. It is also the MIO-16 68-pin connector available when you use the SH1006868 cable assembly with the 6025E.



ACH8	34	68	ACH0
ACH1	33	67	AIGND
AIGND	32	66	ACH9
ACH10	31	65	ACH2
ACH3	30	64	AIGND
AIGND	29	63	ACH11
ACH4	28	62	AISENSE
AIGND	27	61	ACH12
ACH13	26	60	ACH5
ACH6	25	59	AIGND
AIGND	24	58	ACH14
ACH15	23	57	ACH7
DAC0OUT <sup>1</sup>	22	56	AIGND
DAC1OUT <sup>1</sup>	21	55	AOGND
RESERVED	20	54	AOGND
DIO4	19	53	DGND
DGND	18	52	DIO0
DIO1	17	51	DIO5
DIO6	16	50	DGND
DGND	15	49	DIO2
+5 V	14	48	DIO7
DGND	13	47	DIO3
DGND	12	46	SCANCLK
PFI0/TRIG1	11	45	EXTSTROBE*
PFI1/TRIG2	10	44	DGND
DGND	9	43	PFI2/CONVERT*
+5 V	8	42	PFI3/GPCTR1_SOURCE
DGND	7	41	PFI4/GPCTR1_GATE
PFI5/UPDATE*	6	40	GPCTR1_OUT
PFI6/WFTRIG	5	39	DGND
DGND	4	38	PFI7/STARTSCAN
PFI9/GPCTR0_GATE	3	37	PFI8/GPCTR0_SOURCE
GPCTR0_OUT	2	36	DGND
FREQ_OUT	1	35	DGND

<sup>1</sup> Not available on the 6023E

Figure B-1. 68-Pin E Series Connector Pin Assignments

Figure B-2 shows the pin assignments for the 68-pin extended digital input connector. This is the other 68-pin connector available when you use the SH1006868 cable assembly with the 6025E.

GND	34	68	PC7
PC6	33	67	GND
PC5	32	66	GND
GND	31	65	PC4
PC3	30	64	GND
PC2	29	63	GND
GND	28	62	PC1
PC0	27	61	GND
PB7	26	60	GND
GND	25	59	PB6
PB5	24	58	GND
PB4	23	57	GND
GND	22	56	PB3
GND	21	55	PB2
PB1	20	54	GND
PB0	19	53	GND
GND	18	52	PA7
PA6	17	51	GND
PA5	16	50	GND
GND	15	49	PA4
PA3	14	48	GND
PA2	13	47	GND
GND	12	46	PA1
PA0	11	45	GND
+5 V	10	44	GND
N/C	9	43	N/C
N/C	8	42	N/C
N/C	7	41	N/C
N/C	6	40	N/C
N/C	5	39	N/C
N/C	4	38	N/C
N/C	3	37	N/C
N/C	2	36	N/C
N/C	1	35	N/C

**Figure B-2.** 68-Pin Extended Digital Input Connector Pin Assignments

Figure B-3 shows the pin assignments for the 50-pin E Series connector. This connector is available when you use the SH6850 or R6850 cable assemblies with the 6023E and 6024E. It is also one of the two 50-pin connectors available when you use the RI005050 cable assembly with the 6025E.

AIGND	1	2	AIGND
ACH0	3	4	ACH8
ACH1	5	6	ACH9
ACH2	7	8	ACH10
ACH3	9	10	ACH11
ACH4	11	12	ACH12
ACH5	13	14	ACH13
ACH6	15	16	ACH14
ACH7	17	18	ACH15
AISENSE	19	20	DAC0OUT <sup>1</sup>
DAC1OUT <sup>1</sup>	21	22	RESERVED
AOGND	23	24	DGND
DIO0	25	26	DIO4
DIO1	27	28	DIO5
DIO2	29	30	DIO6
DIO3	31	32	DIO7
DGND	33	34	+5 V
+5 V	35	36	SCANCLK
EXTSTROBE*	37	38	PFI0/TRIG1
PFI1/TRIG2	39	40	PFI2/CONVERT*
PFI3/GPCTR1_SOURCE	41	42	PFI4/GPCTR1_GATE
GPCTR1_OUT	43	44	PFI5/UPDATE*
PFI6/WFTRIG	45	46	PFI7/STARTSCAN
PFI8/GPCTR0_SOURCE	47	48	PFI9/GPCTR0_GATE
GPCTR0_OUT	49	50	FREQ_OUT

<sup>1</sup> Not available on the 6023E

**Figure B-3.** 50-Pin E Series Connector Pin Assignments

Figure B-4 shows the pin assignments for the 50-pin extended digital input connector. This is the other 50-pin connector available when you use the R1005050 cable assembly with the 6025E.

PC7	1	2	GND
PC6	3	4	GND
PC5	5	6	GND
PC4	7	8	GND
PC3	9	10	GND
PC2	11	12	GND
PC1	13	14	GND
PC0	15	16	GND
PB7	17	18	GND
PB6	19	20	GND
PB5	21	22	GND
PB4	23	24	GND
PB3	25	26	GND
PB2	27	28	GND
PB1	29	30	GND
PB0	31	32	GND
PA7	33	34	GND
PA6	35	36	GND
PA5	37	38	GND
PA4	39	40	GND
PA3	41	42	GND
PA2	43	44	GND
PA1	45	46	GND
PA0	47	48	GND
+5 V	49	50	GND

**Figure B-4.** 50-Pin Extended Digital Input Connector Pin Assignments



---

# Common Questions

This appendix contains a list of commonly asked questions and their answers relating to usage and special features of your board.

## General Information

---

### What is the DAQ-STC?

The DAQ-STC is the System Timing Control application-specific integrated circuit (ASIC) designed by National Instruments and is the backbone of the E Series boards. The DAQ-STC contains seven 24-bit counters and three 16-bit counters. The counters are divided into the following three groups:

- Analog input—two 24-bit, two 16-bit counters
- Analog output—three 24-bit, one 16-bit counters
- General-purpose counter/timer functions—two 24-bit counters

The groups can be configured independently with timing resolutions of 50 ns or 10  $\mu$ s. With the DAQ-STC, you can interconnect a wide variety of internal timing signals to other internal blocks. The interconnection scheme is quite flexible and completely software configurable. New capabilities such as buffered pulse generation, equivalent time sampling, and seamless changing of the sampling rate are possible.

### What does sampling rate mean to me?

It means that this is the fastest you can acquire data on your board and still achieve accurate results. For example, these boards have a sampling rate of 200 kS/s. This sampling rate is aggregate: one channel at 200 kS/s or two channels at 100 kS/s per channel illustrates the relationship.

### What type of 5 V protection do the boards have?

The boards have 5 V lines equipped with a self-resetting 1 A fuse.

## Installation and Configuration

---

### **How do I set the base address for a my board?**

The base address of your board is assigned automatically through the PCI/PXI bus protocol. This assignment is completely transparent to you.

### **What jumpers should I be aware of when configuring my E Series board?**

The E Series boards are jumperless and switchless.

### **Which National Instruments document should I read first to get started using DAQ software?**

Your NI-DAQ or application software release notes documentation is always the best starting place.

### **What version of NI-DAQ must I have to use my 6023E/6024E/6025E?**

You must have *NI-DAQ for PC Compatibles* version 6.5 or higher.

## Analog Input and Output

---

### **I'm using my board in differential analog input mode and I have connected a differential input signal, but my readings are random and drift rapidly. What's wrong?**

Check your ground reference connections. Your signal may be referenced to a level that is considered *floating* with reference to the board ground reference. Even if you are in differential mode, the signal *must* still be referenced to the same ground level as the board reference. There are various methods of achieving this while maintaining a high common-mode rejection ratio (CMRR). These methods are outlined in Chapter 4, [Signal Connections](#).

### **I'm using the DACs to generate a waveform, but I discovered with a digital oscilloscope that there are glitches on the output signal. Is this normal?**

When it switches from one voltage to another, any DAC produces glitches due to released charges. The largest glitches occur when the most significant bit (MSB) of the D/A code switches. You can build a lowpass deglitching filter to remove some of these glitches, depending on the frequency and nature of your output signal.

### **Can I synchronize a one-channel analog input data acquisition with a one-channel analog output waveform generation on my PCI E Series board?**

Yes. One way to accomplish this is to use the waveform generation timing pulses to control the analog input data acquisition. To do this, follow steps 1 through 4 below, in addition to the usual steps for data acquisition and waveform generation configuration.

1. Enable the PFI5 line for output, as follows:
  - If you are using NI-DAQ, call `Select_Signal(deviceNumber, ND_PFI_5, ND_OUT_UPDATE, ND_HIGH_TO_LOW)`.
  - If you are using LabVIEW, invoke Route Signal VI with signal name set to PFI5 and signal source set to AO Update.
2. Set up data acquisition timing so that the timing signal for A/D conversion comes from PFI5, as follows:
  - If you are using NI-DAQ, call `Select_Signal(deviceNumber, ND_IN_CONVERT, ND_PFI_5, ND_HIGH_TO_LOW)`.
  - If you are using LabVIEW, invoke AI Clock Config VI with clock source code set to PFI pin, high to low, and clock source string set to 5.
3. Initiate analog input data acquisition, which will start only when the analog output waveform generation starts.
4. Initiate analog output waveform generation.

## **Timing and Digital I/O**

---

### **What types of triggering can be hardware-implemented on my board?**

Digital triggering is hardware-supported on every board.

### **Will the counter/timer applications that I wrote previously work with the DAQ-STC?**

If you are using NI-DAQ with LabVIEW, some of your applications drawn using the CTR VIs will still run. However, there are many differences in the counters between the E Series and other boards; the counter numbers are different, timebase selections are different, and the DAQ-STC counters are

24-bit counters (unlike the 16-bit counters on boards without the DAQ-STC).

If you are using the NI-DAQ language interface or LabWindows/CVI, the answer is no, the counter/timer applications that you wrote previously will not work with the DAQ-STC. You must use the GPCTR functions; ICTR and CTR functions will not work with the DAQ-STC. The GPCTR functions have the same capabilities as the ICTR and CTR functions, plus more, but you must rewrite the application with the GPCTR function calls.

**I'm using one of the general-purpose counter/timers on my board, but I do not see the counter/timer output on the I/O connector. What am I doing wrong?**

If you are using the NI-DAQ language interface or LabWindows/CVI, you must configure the output line to output the signal to the I/O connector. Use the `Select_Signal` call in NI-DAQ to configure the output line. By default, all timing I/O lines except EXTSTROBE\* are tri-stated.

**What are the PFIs and how do I configure these lines?**

PFIs are Programmable Function Inputs. These lines serve as connections to virtually all internal timing signals.

If you are using the NI-DAQ language interface or LabWindows/CVI, use the `Select_Signal` function to route internal signals to the I/O connector, route external signals to internal timing sources, or tie internal timing signals together.

If you are using NI-DAQ with LabVIEW and you want to connect external signal sources to the PFI lines, you can use AI Clock Config, AI Trigger Config, AO Clock Config, AO Trigger and Gate Config, CTR Mode Config, and CTR Pulse Config advanced level VIs to indicate which function the connected signal will serve. Use the Route Signal VI to enable the PFI lines to output internal signals.



**Caution** *If you enable a PFI line for output, do not connect any external signal source to it; if you do, you can damage the board, the computer, and the connected equipment.*

**What are the power-on states of the PFI and DIO lines on the I/O connector?**

At system power-on and reset, both the PFI and DIO lines are set to high impedance by the hardware. This means that the board circuitry is not actively driving the output either high or low. However, these lines



may have pull-up or pull-down resistors connected to them as shown in Table 4-2. These resistors weakly pull the output to either a logic high or logic low state. For example, DIO(0) will be in the high impedance state after power on, and Table 4-2 shows that there is a 50 k $\Omega$  pull-up resistor. This pull-up resistor will set the DIO(0) pin to a logic high when the output is in a high impedance state.

---

# Customer Communication

For your convenience, this appendix contains forms to help you gather the information necessary to help us solve your technical problems and a form you can use to comment on the product documentation. When you contact us, we need the information on the Technical Support Form and the configuration form, if your manual contains one, about your system configuration to answer your questions as quickly as possible.

National Instruments has technical assistance through electronic, fax, and telephone systems to quickly provide the information you need. Our electronic services include a bulletin board service, an FTP site, a fax-on-demand system, and e-mail support. If you have a hardware or software problem, first try the electronic support systems. If the information available on these systems does not answer your questions, we offer fax and telephone support through our technical support centers, which are staffed by applications engineers.

## Electronic Services

### Bulletin Board Support

National Instruments has BBS and FTP sites dedicated for 24-hour support with a collection of files and documents to answer most common customer questions. From these sites, you can also download the latest instrument drivers, updates, and example programs. For recorded instructions on how to use the bulletin board and FTP services and for BBS automated information, call 512 795 6990. You can access these services at:

United States: 512 794 5422

Up to 14,400 baud, 8 data bits, 1 stop bit, no parity

United Kingdom: 01635 551422

Up to 9,600 baud, 8 data bits, 1 stop bit, no parity

France: 01 48 65 15 59

Up to 9,600 baud, 8 data bits, 1 stop bit, no parity

### FTP Support

To access our FTP site, log on to our Internet host, `ftp.natinst.com`, as anonymous and use your Internet address, such as `joesmith@anywhere.com`, as your password. The support files and documents are located in the `/support` directories.

## Fax-on-Demand Support

Fax-on-Demand is a 24-hour information retrieval system containing a library of documents on a wide range of technical information. You can access Fax-on-Demand from a touch-tone telephone at 512 418 1111.

## E-Mail Support (Currently USA Only)

You can submit technical support questions to the applications engineering team through e-mail at the Internet address listed below. Remember to include your name, address, and phone number so we can contact you with solutions and suggestions.

support@natinst.com

## Telephone and Fax Support

National Instruments has branch offices all over the world. Use the list below to find the technical support number for your country. If there is no National Instruments office in your country, contact the source from which you purchased your software to obtain support.

<b>Country</b>	<b>Telephone</b>	<b>Fax</b>
Australia	03 9879 5166	03 9879 6277
Austria	0662 45 79 90 0	0662 45 79 90 19
Belgium	02 757 00 20	02 757 03 11
Brazil	011 284 5011	011 288 8528
Canada (Ontario)	905 694 0085	905 785 0086
Canada (Québec)	514 694 8521	514 694 4399
Denmark	45 76 26 00	45 76 26 02
Finland	09 725 725 11	09 725 725 55
France	0 1 48 14 24 24	0 1 48 14 24 14
Germany	089 741 31 30	089 714 60 35
Hong Kong	2645 3186	2686 8505
India	91805275406	91805275410
Israel	03 6120092	03 6120095
Italy	02 413091	02 4139215
Japan	03 5472 2970	03 5472 2977
Korea	02 596 7456	02 596 7455
Mexico (D.F.)	5 280 7625	5 520 3282
Mexico (Monterrey)	8 357 7695	8 365 8543
Netherlands	0348 433466	0348 430673
Norway	32 84 84 00	32 84 86 00
Singapore	2265886	2265887
Spain (Madrid)	91 640 0085	91 640 0533
Spain (Barcelona)	93 582 0251	93 582 4370
Sweden	08 587 895 00	08 730 43 70
Switzerland	056 200 51 51	056 200 51 55
Taiwan	02 2377 1200	02 2737 4644
United Kingdom	01635 523545	01635 523154
United States	512 795 8248	512 794 5678

# Technical Support Form

Photocopy this form and update it each time you make changes to your software or hardware, and use the completed copy of this form as a reference for your current configuration. Completing this form accurately before contacting National Instruments for technical support helps our applications engineers answer your questions more efficiently.

If you are using any National Instruments hardware or software products related to this problem, include the configuration forms from their user manuals. Include additional pages if necessary.

Name \_\_\_\_\_

Company \_\_\_\_\_

Address \_\_\_\_\_

\_\_\_\_\_

Fax ( \_\_\_\_ ) \_\_\_\_\_ Phone ( \_\_\_\_ ) \_\_\_\_\_

Computer brand \_\_\_\_\_ Model \_\_\_\_\_ Processor \_\_\_\_\_

Operating system (include version number) \_\_\_\_\_

Clock speed \_\_\_\_\_ MHz RAM \_\_\_\_\_ MB Display adapter \_\_\_\_\_

Mouse \_\_\_yes \_\_\_no Other adapters installed \_\_\_\_\_

Hard disk capacity \_\_\_\_\_ MB Brand \_\_\_\_\_

Instruments used \_\_\_\_\_

\_\_\_\_\_

National Instruments hardware product model \_\_\_\_\_ Revision \_\_\_\_\_

Configuration \_\_\_\_\_

National Instruments software product \_\_\_\_\_ Version \_\_\_\_\_

Configuration \_\_\_\_\_

The problem is: \_\_\_\_\_

\_\_\_\_\_

\_\_\_\_\_

\_\_\_\_\_

\_\_\_\_\_

List any error messages: \_\_\_\_\_

\_\_\_\_\_

\_\_\_\_\_

The following steps reproduce the problem: \_\_\_\_\_

\_\_\_\_\_

\_\_\_\_\_

\_\_\_\_\_

\_\_\_\_\_

# 6023E/6024E/6025E Hardware and Software Configuration Form

Record the settings and revisions of your hardware and software on the line to the right of each item. Complete a new copy of this form each time you revise your software or hardware configuration, and use this form as a reference for your current configuration. Completing this form accurately before contacting National Instruments for technical support helps our applications engineers answer your questions more efficiently.

## National Instruments Products

Board Serial Number \_\_\_\_\_

Hardware revision \_\_\_\_\_

Interrupt level of hardware \_\_\_\_\_

DMA channels of hardware \_\_\_\_\_

Base I/O address of hardware \_\_\_\_\_

Programming choice \_\_\_\_\_

National Instruments software \_\_\_\_\_

Other boards in system \_\_\_\_\_

Base I/O address of other boards \_\_\_\_\_

DMA channels of other boards \_\_\_\_\_

Interrupt level of other boards \_\_\_\_\_

## Other Products

Computer make and model \_\_\_\_\_

Microprocessor \_\_\_\_\_

Clock frequency or speed \_\_\_\_\_

Type of video board installed \_\_\_\_\_

Operating system version \_\_\_\_\_

Operating system mode \_\_\_\_\_

Programming language \_\_\_\_\_

Programming language version \_\_\_\_\_

Other boards in system \_\_\_\_\_

Base I/O address of other boards \_\_\_\_\_

DMA channels of other boards \_\_\_\_\_

Interrupt level of other boards \_\_\_\_\_

# Documentation Comment Form

National Instruments encourages you to comment on the documentation supplied with our products. This information helps us provide quality products to meet your needs.

**Title:** *6023E/6024E/6025E User Manual*

**Edition Date:** January 1999

**Part Number:** 322072B-01

Please comment on the completeness, clarity, and organization of the manual.

---

---

---

---

---

---

---

---

If you find errors in the manual, please record the page numbers and describe the errors.

---

---

---

---

---

---

---

---

Thank you for your help.

Name \_\_\_\_\_

Title \_\_\_\_\_

Company \_\_\_\_\_

Address \_\_\_\_\_

E-Mail Address \_\_\_\_\_

Phone ( \_\_\_\_ ) \_\_\_\_\_ Fax ( \_\_\_\_ ) \_\_\_\_\_

**Mail to:** Technical Publications  
National Instruments Corporation  
6504 Bridge Point Parkway  
Austin, Texas 78730-5039

**Fax to:** Technical Publications  
National Instruments Corporation  
512 794 5678

# Glossary

---

Prefix	Meanings	Value
p-	pico	$10^{-12}$
n-	nano-	$10^{-9}$
$\mu$ -	micro-	$10^{-6}$
m-	milli-	$10^{-3}$
k-	kilo-	$10^3$
M-	mega-	$10^6$
G-	giga-	$10^9$
t-	tera-	$10^{12}$

## Numbers/Symbols

°	degree
>	greater than
<	less than
-	negative of, or minus
$\Omega$	ohm
/	per
%	percent
$\pm$	plus or minus
+	positive of, or plus
$\sqrt{\quad}$	square root of
+5 V	+5 VDC source signal

## A

A	amperes
AC	alternating current
ACH	analog input channel signal
A/D	analog-to-digital
ADC	analog-to-digital converter—an electronic device, often an integrated circuit, that converts an analog voltage to a digital number
ADC resolution	the resolution of the ADC, which is measured in bits. An ADC with 16 bits has a higher resolution, and thus a higher degree of accuracy, than a 12-bit ADC.
AI	analog input
AIGATE	analog input gate signal
AIGND	analog input ground signal
AISENSE	analog input sense signal
alias	a false lower frequency component that appears in sampled data acquired at too low a sampling rate
ANSI	American National Standards Institute
AO	analog output
AOGND	analog output ground signal
ASIC	Application-Specific Integrated Circuit—a proprietary semiconductor component designed and manufactured to perform a set of specific functions for a specific customer
asynchronous	(1) hardware—a property of an event that occurs at an arbitrary time, without synchronization to a reference clock (2) software—a property of a function that begins an operation and returns prior to the completion or termination of the operation



**B**

bandwidth	the range of frequencies present in a signal, or the range of frequencies to which a measuring device can respond
base address	a memory address that serves as the starting address for programmable registers. All other addresses are located by adding to the base address.
BIOS	basic input/output system—BIOS functions are the fundamental level of any PC or compatible computer. BIOS functions embody the basic operations needed for successful use of the computer's hardware resources.
bipolar	a signal range that includes both positive and negative values (for example, $-5\text{ V}$ to $+5\text{ V}$ )
breakdown voltage	the voltage high enough to cause breakdown of optical isolation, semiconductors, or dielectric materials. <i>See also</i> working voltage.
bus	the group of conductors that interconnect individual circuitry in a computer. Typically, a bus is the expansion vehicle to which I/O or other devices are connected. Examples of PC buses are the ISA and PCI bus.
bus master	a type of a plug-in board or controller with the ability to read and write devices on the computer bus

**C**

C	Celsius
CalDAC	calibration DAC
CH	channel—pin or wire lead to which you apply or from which you read the analog or digital signal. Analog signals can be single-ended or differential. For digital signals, you group channels to form ports. Ports usually consist of either four or eight digital channels.
channel clock	the clock controlling the time interval between individual channel sampling within a scan. Boards with simultaneous sampling do not have this clock.
CMRR	common-mode rejection ratio—a measure of an instrument's ability to reject interference from a common-mode signal, usually expressed in decibels (dB)

cold-junction compensation	a method of compensating for inaccuracies in thermocouple circuits
common-mode range	the input range over which a circuit can handle a common-mode signal
common-mode signal	the mathematical average voltage, relative to the computer's ground, of the signals from a differential input
conversion time	the time required, in an analog input or output system, from the moment a channel is interrogated (such as with a read instruction) to the moment that accurate data is available
CONVERT*	convert signal
counter/timer	a circuit that counts external pulses or clock pulses (timing)
crosstalk	an unwanted signal on one channel due to an input on a different channel
CTR	counter
current drive capability	the amount of current a digital or analog output channel is capable of sourcing or sinking while still operating within voltage range specifications
current sinking	the ability of a DAQ board to dissipate current for analog or digital output signals
current sourcing	the ability of a DAQ board to supply current for analog or digital output signals

## **D**

D/A	digital-to-analog
DAC	digital-to-analog converter—an electronic device, often an integrated circuit, that converts a digital number into a corresponding analog voltage or current
DAC0OUT	analog channel 0 output signal
DAC1OUT	analog channel 1 output signal

DAQ	data acquisition—(1) collecting and measuring electrical signals from sensors, transducers, and test probes or fixtures and inputting them to a computer for processing; (2) collecting and measuring the same kinds of electrical signals with A/D and/or DIO boards plugged into a computer, and possibly generating control signals with D/A and/or DIO boards in the same computer
dB	decibel—the unit for expressing a logarithmic measure of the ratio of two signal levels: $dB=20\log_{10} V1/V2$ , for signals in volts
DC	direct current
DGND	digital ground signal
DIFF	differential mode
differential input	an analog input consisting of two terminals, both of which are isolated from computer ground, whose difference is measured
digital port	<i>See</i> port.
DIO	digital input/output
dithering	the addition of Gaussian noise to an analog input signal
DMA	direct memory access—a method by which data can be transferred to/from computer memory from/to a device or memory on the bus while the processor does something else. DMA is the fastest method of transferring data to/from computer memory.
DNL	differential nonlinearity—a measure in least significant bit of the worst-case deviation of code widths from their ideal value of 1 LSB
DO	digital output
drivers	software that controls a specific hardware device such as a DAQ board or a GPIB interface board
<b>E</b>	
EEPROM	electrically erasable programmable read-only memory—ROM that can be erased with an electrical signal and reprogrammed
electrostatically coupled	propagating a signal by means of a varying electric field

external trigger      a voltage pulse from an external source that triggers an event such as A/D conversion

EXTSTROBE      external strobe signal

## F

FIFO      first-in first-out memory buffer—the first data stored is the first data sent to the acceptor. FIFOs are often used on DAQ devices to temporarily store incoming or outgoing data until that data can be retrieved or output. For example, an analog input FIFO stores the results of A/D conversions until the data can be retrieved into system memory, a process that requires the servicing of interrupts and often the programming of the DMA controller. This process can take several milliseconds in some cases. During this time, data accumulates in the FIFO for future retrieval. With a larger FIFO, longer latencies can be tolerated. In the case of analog output, a FIFO permits faster update rates, because the waveform data can be stored on the FIFO ahead of time. This again reduces the effect of latencies associated with getting the data from system memory to the DAQ device.

filtering      a type of signal conditioning that allows you to filter unwanted signals from the signal you are trying to measure

floating signal sources      signal sources with voltage signals that are not connected to an absolute reference or system ground. Also called nonreferenced signal sources. Some common example of floating signal sources are batteries, transformers, or thermocouples.

FREQ\_OUT      frequency output signal

ft      feet

## G

g      grams

gain      the factor by which a signal is amplified, sometimes expressed in decibels

gain accuracy      a measure of deviation of the gain of an amplifier from the ideal gain

GATE      gate signal

glitch      an unwanted momentary deviation from a desired signal

GPCTR	general purpose counter
GPCTR0_GATE	general purpose counter 0 gate signal
GPCTR0_OUT	general purpose counter 0 output signal
GPCTR0_SOURCE	general purpose counter 0 clock source signal
GPCTR0_UP_DOWN	general purpose counter 0 up down
GPCTR1_GATE	general purpose counter 1 gate signal
GPCTR1_OUT	general purpose counter 1 output signal
GPCTR1_SOURCE	general purpose counter 1 clock source signal
GPCTR1_UP_DOWN	general purpose counter 1 up down
GPIB	General Purpose Interface bus, synonymous with HP-IB. The standard bus used for controlling electronic instruments with a computer. Also called IEEE 488 bus because it is defined by ANSI/IEEE Standards 488-1978, 488.1-1987, and 488.2-1987.
grounded measurement system	<i>See</i> referenced single-ended measurement system.
<b>H</b>	
h	hour
half-power bandwidth	the frequency range over which a circuit maintains a level of at least $-3$ dB with respect to the maximum level
handshaked digital I/O	a type of digital acquisition/generation where a device or module accepts or transfers data after a digital pulse has been received. Also called latched digital I/O.
hex	hexadecimal
Hz	hertz—the number of events per second

**I**

in.	inches
INL	integral nonlinearity—a measure in LSB of the worst-case deviation from the ideal A/D or D/A transfer characteristic of the analog I/O circuitry
input bias current	the current that flows into the inputs of a circuit
input impedance	the resistance and capacitance between the input terminals of a circuit
input offset current	the difference in the input bias currents of the two inputs of an instrumentation amplifier
instrument driver	a set of high-level software functions that controls a specific GPIB, VXI, or RS-232 programmable instrument or a specific plug-in DAQ board. Instrument drivers are available in several forms, ranging from a function callable language to a virtual instrument (VI) in LabVIEW.
instrumentation amplifier	a circuit whose output voltage with respect to ground is proportional to the difference between the voltages at its two high impedance inputs
interrupt	a computer signal indicating that the CPU should suspend its current task to service a designated activity
interrupt level	the relative priority at which a device can interrupt
interval scanning	scanning method where there is a longer interval between scans than there is between individual channels comprising a scan
I/O	input/output—the transfer of data to/from a computer system involving communications channels, operator interface devices, and/or data acquisition and control interfaces
$I_{OH}$	current, output high
$I_{OL}$	current, output low
IRQ	interrupt request

**K**

k	kilo—the standard metric prefix for 1,000, or $10^3$ , used with units of measure such as volts, hertz, and meters
---	--------------------------------------------------------------------------------------------------------------------

K	kilo—the prefix for 1,024, or $2^{10}$ , used with B in quantifying data or computer memory
kS	1,000 samples
<b>L</b>	
LabVIEW	laboratory virtual instrument engineering workbench
LED	light-emitting diode
library	a file containing compiled object modules, each comprised of one of more functions, that can be linked to other object modules that make use of these functions. NIDAQMSC.LIB is a library that contains NI-DAQ functions. The NI-DAQ function set is broken down into object modules so that only the object modules that are relevant to your application are linked in, while those object modules that are not relevant are not linked.
linearity	the adherence of device response to the equation $R = KS$ , where R = response, S = stimulus, and K = a constant
LSB	least significant bit
<b>M</b>	
MIO	multifunction I/O
MITE	MXI Interface to Everything—a custom ASIC designed by National Instruments that implements the PCI bus interface. The MITE supports bus mastering for high-speed data transfers over the PCI bus.
MS	million samples
MSB	most significant bit
mux	multiplexer—a switching device with multiple inputs that sequentially connects each of its inputs to its output, typically at high speeds, in order to measure several signals with a single analog input channel
<b>N</b>	
NC	normally closed, or not connected

NI-DAQ	National Instruments driver software for DAQ hardware
noise	an undesirable electrical signal—Noise comes from external sources such as the AC power line, motors, generators, transformers, fluorescent lights, soldering irons, CRT displays, computers, electrical storms, welders, radio transmitters, and internal sources such as semiconductors, resistors, and capacitors. Noise corrupts signals you are trying to send or receive.
nonlatched digital I/O	a type of digital acquisition/generation where LabVIEW updates the digital lines or port states immediately or returns the digital value of an input line. Also called immediate digital I/O or non-handshaking.
nonreferenced signal sources	signal sources with voltage signals that are not connected to an absolute reference or system ground. Also called floating signal sources. Some common example of nonreferenced signal sources are batteries, transformers, or thermocouples.
NRSE	nonreferenced single-ended mode—all measurements are made with respect to a common (NRSE) measurement system reference, but the voltage at this reference can vary with respect to the measurement system ground

## **O**

OUT	output pin—a counter output pin where the counter can generate various TTL pulse waveforms
output settling time	the amount of time required for the analog output voltage to reach its final value within specified limits
output slew rate	the maximum rate of change of analog output voltage from one level to another

## **P**

PCI	Peripheral Component Interconnect—a high-performance expansion bus architecture originally developed by Intel to replace ISA and EISA. It is achieving widespread acceptance as a standard for PCs and work-stations; it offers a theoretical maximum transfer rate of 132 Mbytes/s.
peak to peak	a measure of signal amplitude; the difference between the highest and lowest excursions of the signal



PFI	programmable function input
PFI0/TRIG1	PFI0/trigger 1
PFI1/TRIG2	PFI1/trigger 2
PFI2/CONVERT*	PFI2/convert
PFI3/GPCTR1_ SOURCE	PFI3/general purpose counter 1 source
PFI4/GPCTR1_GATE	PFI4/general purpose counter 1 gate
PFI5/UPDATE*	PFI5/update
PFI6/WFTRIG	PFI6/waveform trigger
PFI7/STARTSCAN	PFI7/start of scan
PFI8/GPCTR0_ SOURCE	PFI8/general purpose counter 0 source
PFI9/GPCTR0_GATE	PFI9/general purpose counter 0 gate
PGIA	programmable gain instrumentation amplifier
Plug and Play devices	devices that do not require DIP switches or jumpers to configure resources on the devices—also called switchless devices
port	(1) a communications connection on a computer or a remote controller (2) a digital port, consisting of four or eight lines of digital input and/or output
posttriggering	the technique used on a DAQ board to acquire a programmed number of samples after trigger conditions are met
PPI	programmable peripheral interface
ppm	parts per million
pretriggering	the technique used on a DAQ board to keep a continuous buffer filled with data, so that when the trigger conditions are met, the sample includes the data leading up to the trigger condition
pts	points

pu	pullup
pulse trains	multiple pulses
pulsed output	a form of counter signal generation by which a pulse is outputted when a counter reaches a certain value

## Q

quantization error	the inherent uncertainty in digitizing an analog value due to the finite resolution of the conversion process
--------------------	---------------------------------------------------------------------------------------------------------------

## R

RAM	random-access memory
real time	a property of an event or system in which data is processed as it is acquired instead of being accumulated and processed at a later time
referenced signal sources	signal sources with voltage signals that are referenced to a system ground, such as the earth or a building ground. Also called grounded signal sources.
relative accuracy	a measure in LSB of the accuracy of an ADC. It includes all non-linearity and quantization errors. It does not include offset and gain errors of the circuitry feeding the ADC.
resolution	the smallest signal increment that can be detected by a measurement system. Resolution can be expressed in bits, in proportions, or in percent of full scale. For example, a system has 12-bit resolution, one part in 4,096 resolution, and 0.0244% of full scale.
ribbon cable	a flat cable in which the conductors are side by side
rise time	the difference in time between the 10% and 90% points of a system's step response
rms	root mean square—the square root of the average value of the square of the instantaneous signal amplitude; a measure of signal amplitude
RSE	referenced single-ended mode—all measurements are made with respect to a common reference measurement system or a ground. Also called a grounded measurement system.

RTSI bus	real-time system integration bus—the National Instruments timing bus that connects DAQ boards directly, for precise synchronization of functions. For PCI boards, the connection is made by means of connectors on top of the board. For PXI boards, the connection is made across the PXI trigger bus.
<b>S</b>	
s	seconds
S	samples
sample counter	the clock that counts the output of the channel clock, in other words, the number of samples taken. On boards with simultaneous sampling, this counter counts the output of the scan clock and hence the number of scans.
scan	one or more analog or digital input samples. Typically, the number of input samples in a scan is equal to the number of channels in the input group. For example, one pulse from the scan clock produces one scan which acquires one new sample from every analog input channel in the group.
scan clock	the clock controlling the time interval between scans.
scan rate	the number of scans per second. For example, a scan rate of 10 Hz means sampling each channel 10 times per second.
SCXI	Signal Conditioning eXtensions for Instrumentation—the National Instruments product line for conditioning low-level signals within an external chassis near sensors so only high-level signals are sent to DAQ boards in the noisy PC environment
SE	single-ended—a term used to describe an analog input that is measured with respect to a common ground
self-calibrating	a property of a DAQ board that has an extremely stable onboard reference and calibrates its own A/D and D/A circuits without manual adjustments by the user
sensor	a device that responds to a physical stimulus (heat, light, sound, pressure, motion, flow, and so on), and produces a corresponding electrical signal
settling time	the amount of time required for a voltage to reach its final value within specified limits

Shannon Sampling Theorem	a law of sampling theory stating that if a continuous bandwidth-limited signal contains no frequency components higher than half the frequency at which it is sampled, then the original signal can be recovered without distortion
S/H	sample-and-hold—a circuit that acquires and stores an analog voltage on a capacitor for a short period of time
signal conditioning	the manipulation of signals to prepare them for digitizing
SISOURCE	SI counter clock signal
SNR	signal-to-noise ratio—the ratio of the overall rms signal level to the rms noise level, expressed in decibels
software trigger	a programmed event that triggers an event such as data acquisition
software triggering	a method of triggering in which you simulate an analog trigger using software. Also called conditional retrieval.
SOURCE	source signal
SS	simultaneous sampling—a property of a system in which each input or output channel is digitized or updated at the same instant
S/s	samples per second—used to express the rate at which a DAQ board samples an analog signal
STARTSCAN	start scan signal
STC	system timing controller
synchronous	(1) hardware—a property of an event that is synchronized to a reference clock (2) software—a property of a function that begins an operation and returns only when the operation is complete
<b>T</b>	
TC	terminal count—the highest value of a counter
T/H	track-and-hold—a circuit that tracks an analog voltage and holds the value on command

THD	total harmonic distortion—the ratio of the total rms signal due to harmonic distortion to the overall rms signal, in decibel or a percentage
THD+N	signal-to-THD plus noise—the ratio in decibels of the overall rms signal to the rms signal of harmonic distortion plus noise introduced
throughput rate	the data, measured in bytes/s, for a given continuous operation, calculated to include software overhead
transducer	<i>See</i> sensor
transfer rate	the rate, measured in bytes/s, at which data is moved from source to destination after software initialization and set up operations; the maximum rate at which the hardware can operate
TRIG	trigger signal
trigger	any event that causes or starts some form of data capture
TTL	transistor-transistor logic
<b>U</b>	
UI	update interval
unipolar	a signal range that is always positive (for example, 0 to +10 V)
UISOURCE	update interval counter clock signal
update	the output equivalent of a scan. One or more analog or digital output samples. Typically, the number of output samples in an update is equal to the number of channels in the output group. For example, one pulse from the update clock produces one update which sends one new sample to every analog output channel in the group.
update rate	the number of output updates per second
<b>V</b>	
V	volts
Vcc	positive supply voltage

VDC	volts direct current
VI	virtual instrument—(1) a combination of hardware and/or software elements, typically used with a PC, that has the functionality of a classic stand-alone instrument (2) a LabVIEW software module (VI), which consists of a front panel user interface and a block diagram program
$V_{IH}$	volts, input high
$V_{IL}$	volts, input low
$V_{in}$	volts in
$V_m$	measured voltage
$V_{OH}$	volts, output high
$V_{OL}$	volts, output low
$V_{ref}$	reference voltage
$V_{rms}$	volts, root mean square

## W

waveform	multiple voltage readings taken at a specific sampling rate
WFTRIG	waveform generation trigger signal
working voltage	the highest voltage that should be applied to a product in normal use, normally well under the breakdown voltage for safety margin. <i>See also</i> breakdown voltage.

# Index

---

## Numbers

- +5 V signal
  - description (table), 4-4
  - self-resetting fuse, C-1
- 82C55A Programmable Peripheral Interface. *See* PPI (Programmable Peripheral Interface).
- 6023E/6024E/6025E boards. *See also* hardware overview.
  - block diagram, 3-1
  - features, 1-1 to 1-2
  - optional equipment, 1-6
  - requirements for getting started, 1-2 to 1-3
  - software programming choices, 1-3 to 1-6
    - National Instruments application software, 1-4
    - NI-DAQ driver software, 1-4 to 1-5
    - register-level programming, 1-6
  - unpacking, 1-3
  - using PXI with CompactPCI, 1-2

## A

- ACH<0..15> signal
  - description (table), 4-4
  - signal summary (table), 4-7
- ACK\* signal
  - description (table), 4-25
  - mode 1 output timing (figure), 4-28
  - mode 2 bidirectional timing (figure), 4-29
- acquisition timing connections. *See* DAQ timing connections.
- AIGATE signal, 4-39
- AIGND signal
  - analog input mode, 4-10
  - description (table), 4-4
  - signal summary (table), 4-7
- AISENSE signal

- description (table), 4-4
- NRSE mode, 4-10
- signal summary (table), 4-7
- analog input
  - available input configurations (table), 3-2
  - common questions, C-2 to C-3
  - dither, 3-3 to 3-4
  - input modes, 3-2
  - input range, 3-2 to 3-3
  - multichannel scanning considerations, 3-4 to 3-5
- analog input signal connections, 4-9 to 4-11
  - common-mode signal rejection considerations, 4-19
  - differential connections, 4-13 to 4-16
    - ground-referenced signal sources, 4-14
    - nonreferenced or floating signal sources, 4-15 to 4-16
  - exceeding common-mode input ranges (caution), 4-10
  - PGIA (figure), 4-10
  - recommended input connections (figure), 4-12
  - single-ended connection, 4-17 to 4-19
    - floating signal sources (RSE configuration), 4-18
    - grounded signal sources (NRSE configuration), 4-18 to 4-19
  - summary of input connections (table), 4-12
  - types of signal sources, 4-8 to 4-9
    - floating signal sources, 4-8 to 4-9
    - ground-referenced signal sources, 4-9
- analog input specifications, A-1 to A-4
  - accuracy information, A-2
  - amplifier characteristics, A-3
  - dynamic characteristics, A-4
  - input characteristics, A-1 to A-2
  - stability, A-4

- transfer characteristics, A-3
- analog output
  - analog output glitch, 3-5
  - common questions, C-2 to C-3
  - overview, 3-5
  - signal connections, 4-20
- analog output specifications, A-4 to A-6
  - accuracy information, A-5
  - dynamic characteristics, A-6
  - output characteristics, A-4 to A-5
  - stability, A-6
  - transfer characteristics, A-5 to A-6
  - voltage output, A-6
- AOGND signal
  - description (table), 4-4
  - signal summary (table), 4-7

**B**

- bipolar input, 3-2
- block diagram, 3-1
- board and RTSI clocks, 3-8
- bulletin board support, D-1

**C**

- cables. *See also* I/O connectors.
  - custom cabling, B-1 to B-2
  - field wiring considerations, 4-49 to 4-50
  - optional equipment, 1-6
- calibration, 5-1 to 5-3
  - adjusting gain error, 5-3
  - external calibration, 5-2
  - loading calibration constants, 5-1 to 5-2
  - self-calibration, 5-2
  - specifications, A-9
- charge injection, 3-5
- clocks, board and RTSI, 3-8
- commonly asked questions. *See* questions and answers.

- common-mode signal rejection
  - considerations, 4-19
- CompactPCI products, using with PXI, 1-2
- ComponentWorks software, 1-4
- configuration
  - common questions, C-2
  - hardware configuration, 2-3
- connectors. *See* I/O connectors.
- CONVERT\* signal
  - DAQ timing connections, 4-38 to 4-39
  - signal routing (figure), 3-7
- custom cabling, B-1 to B-2
- customer communication, *xiv*, D-1 to D-2

## D

- DAC0OUT signal
  - analog output signal connections, 4-20
  - description (table), 4-4
  - signal summary (table), 4-7
- DAC1OUT signal
  - analog output signal connections, 4-20
  - description (table), 4-4
  - signal summary (table), 4-7
- DAQ timing connections, 4-32 to 4-40
  - AIGATE signal, 4-39
  - CONVERT\* signal, 4-38 to 4-39
  - EXTSTROBE\* signal, 4-33 to 4-34
  - SCANCLK signal, 4-33
  - SISOURCE signal, 4-40
  - STARTSCAN signal, 4-36 to 4-38
  - TRIG1 signal, 4-34 to 4-35
  - TRIG2 signal, 4-35 to 4-36
  - typical posttriggered acquisition
    - (figure), 4-32
  - typical pretriggered acquisition
    - (figure), 4-33
- DAQ-STC, C-1
- DATA signal
  - description (table), 4-26
  - mode 1 input timing (figure), 4-27



mode 1 output timing (figure), 4-28  
mode 2 bidirectional timing (figure), 4-29

DGND signal  
description (table), 4-4  
signal summary (table), 4-7

DIFF mode  
description (table), 3-2  
recommended configuration  
(figure), 4-12

differential connections, 4-13 to 4-16  
ground-referenced signal sources, 4-14  
nonreferenced or floating signal sources,  
4-15 to 4-16  
when to use, 4-13

digital I/O. *See also* PPI (Programmable  
Peripheral Interface).  
common questions, C-3 to C-5  
overview, 3-6  
signal connections, 4-21

digital I/O specifications, A-7 to A-8  
DIO<0..7>, A-7  
PA<0..7>, PB<0..7>, PC<0..7>,  
A-7 to A-8

digital trigger specifications, A-9

DIO power-up state, changing to pulled low,  
4-24 to 4-25

DIO<0..7> signal  
description (table), 4-4  
digital I/O signal connections, 4-21  
digital I/O specifications, A-7  
signal summary (table), 4-7

dither, 3-3 to 3-4

documentation  
conventions used in manual, *xii-xiii*  
National Instruments documentation, *xiii*  
organization of manual, *xi-xii*  
related documentation, *xiv*

## E

EEPROM storage of calibration constants, 5-1

electronic support services, D-1 to D-2

e-mail support, D-2

environmental noise, 4-49 to 4-50

equipment, optional, 1-6

EXTSTROBE\* signal  
DAQ timing connections, 4-33 to 4-34  
description (table), 4-5  
signal summary (table), 4-7

## F

fax and telephone support numbers, D-2

Fax-on-Demand support, D-2

field wiring considerations, 4-49 to 4-50

floating signal sources  
description, 4-8 to 4-9  
differential connections, 4-15 to 4-16  
single-ended connections (RSE  
configuration), 4-18

FREQ\_OUT signal  
description (table), 4-6  
general-purpose timing signal  
connections, 4-49  
signal summary (table), 4-8

frequently asked questions. *See* questions and  
answers.

FTP support, D-1

fuse, self-resetting, C-1

## G

gain error, adjusting, 5-3

general-purpose timing signal connections,  
4-43 to 4-49  
FREQ\_OUT signal, 4-49  
GPCTR0\_GATE signal, 4-44  
GPCTR0\_OUT signal, 4-45  
GPCTR0\_SOURCE signal, 4-43 to 4-44  
GPCTR0\_UP\_DOWN signal, 4-45

- GPCTR1\_GATE signal, 4-46 to 4-47
- GPCTR1\_OUT signal, 4-47
- GPCTR1\_SOURCE signal, 4-45 to 4-46
- GPCTR1\_UP\_DOWN signal, 4-47 to 4-49
- glitch, analog output, 3-5
- GPCTR0\_GATE signal, 4-44
- GPCTR0\_OUT signal
  - description (table), 4-6
  - general-purpose timing signal connections, 4-45
  - signal summary (table), 4-8
- GPCTR0\_SOURCE signal, 4-43 to 4-44
- GPCTR0\_UP\_DOWN signal, 4-45
- GPCTR1\_GATE signal, 4-46 to 4-47
- GPCTR1\_OUT signal
  - description (table), 4-5
  - general-purpose timing signal connections, 4-47
  - signal summary (table), 4-8
- GPCTR1\_SOURCE signal, 4-45 to 4-46
- GPCTR1\_UP\_DOWN signal, 4-47 to 4-49
- ground-referenced signal sources
  - description, 4-9
  - differential connections, 4-14
  - single-ended connections (NRSE configuration), 4-18 to 4-19

## H

- hardware
  - configuration, 2-3
  - installation, 2-1 to 2-3
- hardware overview
  - analog input, 3-2 to 3-5
    - dither, 3-3 to 3-4
    - input mode, 3-2
    - input range, 3-2 to 3-3
  - analog output, 3-5
  - block diagram, 3-1
  - digital I/O, 3-6

- timing signal routing, 3-6 to 3-10
  - board and RTSI clocks, 3-8
  - programmable function inputs, 3-7 to 3-8
  - RTSI triggers, 3-8 to 3-10

## I

- IBF signal
  - description (table), 4-25
  - mode 1 input timing (figure), 4-27
  - mode 2 bidirectional timing (figure), 4-29
- input modes, 3-2. *See also* analog input.
- input range, 3-2 to 3-3
  - exceeding common-mode input ranges (caution), 4-10
  - measurement precision (table), 3-3
- installation
  - common questions, C-2
  - hardware, 2-1 to 2-3
  - software, 2-1
  - unpacking 6023E/6024E/6025E, 1-3
- INTR signal
  - description (table), 4-26
  - mode 1 input timing (figure), 4-27
  - mode 1 output timing (figure), 4-28
  - mode 2 bidirectional timing (figure), 4-29
- I/O connectors, 4-1 to 4-8
  - exceeding maximum ratings (warning), 4-1
  - optional connectors, B-2 to B-6
    - 50-pin E Series connector pin assignments (figure), B-5
    - 50-pin extended digital input connector pin assignments (figure), B-6
    - 68-pin E Series connector pin assignments (figure), B-3
    - 68-pin extended digital input connector pin assignments (figure), B-4

pin assignments (table)  
 6023E/6024E, 4-2  
 6025E, 4-3

## L

LabVIEW and LabWindows/CVI application software, 1-4

## M

manual. *See* documentation.  
 mode 1 input timing (figure), 4-27  
 mode 1 output timing (figure), 4-28  
 mode 2 bidirectional timing (figure), 4-29  
 multichannel scanning considerations, 3-4 to 3-5

## N

NI-DAQ driver software, 1-4 to 1-5  
 noise, environmental, 4-49 to 4-50  
 NRSE (nonreferenced single-ended) mode configuration, 4-10  
 description (table), 3-2  
 differential connections, 4-15 to 4-16  
 recommended configuration (figure), 4-12  
 single-ended connections for ground-referenced signal sources, 4-18 to 4-19

## O

OBF\* signal  
 description (table), 4-26  
 mode 1 output timing (figure), 4-28  
 mode 2 bidirectional timing (figure), 4-29  
 operating environment specifications, A-10  
 optional equipment, 1-6

## P

PA<0..7> signal  
 description (table), 4-4  
 digital I/O specifications, A-7 to A-8  
 signal summary (table), 4-7  
 PB<0..7> signal  
 description (table), 4-4  
 digital I/O specifications, A-7 to A-8  
 signal summary (table), 4-7  
 PC<0..7> signal  
 description (table), 4-4  
 digital I/O specifications, A-7 to A-8  
 signal summary (table), 4-7  
 PFI0/TRIG1 signal  
 description (table), 4-5  
 signal summary (table), 4-7  
 PFI1/TRIG2 signal  
 description (table), 4-5  
 signal summary (table), 4-7  
 PFI2/CONVERT\* signal  
 description (table), 4-5  
 signal summary (table), 4-7  
 PFI3/GPCTR1\_SOURCE signal  
 description (table), 4-5  
 signal summary (table), 4-7  
 PFI4/GPCTR1\_GATE signal  
 description (table), 4-5  
 signal summary (table), 4-8  
 PFI5/UPDATE signal  
 description (table), 4-6  
 signal summary (table), 4-8  
 PFI6/WFTRIG signal  
 description (table), 4-6  
 signal summary (table), 4-8  
 PFI7/STARTSCAN signal  
 description (table), 4-6  
 signal summary (table), 4-8  
 PFI8/GPCTR0\_SOURCE signal  
 description (table), 4-6  
 signal summary (table), 4-8

- PFI9/GPCTRO\_GATE signal
    - description (table), 4-6
    - signal summary (table), 4-8
  - PFI9s (programmable function inputs)
    - common questions, C-4 to C-5
    - signal routing, 3-7 to 3-8
    - timing connections, 4-31 to 4-32
  - PGIA (programmable gain instrumentation amplifier)
    - analog input modes, 4-10 to 4-11
    - differential connections
      - ground-referenced signal sources (figure), 4-14
      - nonreferenced or floating signal sources, 4-15 to 4-16
    - single-ended connections
      - floating signal sources (figure), 4-18
      - ground-referenced signal sources (figure), 4-19
  - physical specifications, A-9 to A-10
  - pin assignments
    - 6023E/6024E (figure), 4-2
    - 6025E (figure), 4-3
  - Port C pin assignments
    - description, 4-23
    - signal assignments (table), 4-23
  - posttriggered acquisition (figure), 4-32
  - power connections, 4-30
  - power requirement specifications, A-9
  - power-up state, digital I/O, 4-24 to 4-25
  - PPI (Programmable Peripheral Interface)
    - 6025E only, 4-22 to 4-23
    - changing DIO power-up state to pulled low, 4-24 to 4-25
    - digital I/O connections block diagram (figure), 4-22
    - mode 1 input timing (figure), 4-27
    - mode 1 output timing (figure), 4-28
    - mode 2 bidirectional timing (figure), 4-29
    - Port C pin assignments, 4-23
    - power-up state, 4-24 to 4-25
    - signal names used in diagrams (table), 4-25 to 4-26
    - timing specifications, 4-25 to 4-29
  - pretriggered acquisition (figure), 4-33
  - programmable function inputs (PFIs). *See* PFIs (programmable function inputs).
  - programmable gain instrumentation amplifier. *See* PGIA (programmable gain instrumentation amplifier).
  - Programmable Peripheral Interface (PPI). *See* PPI (Programmable Peripheral Interface).
  - PXI products, using with CompactPCI, 1-2
- ## Q
- questions and answers, C-1 to C-5
    - analog input and output, C-2 to C-3
    - general information, C-1
    - installation and configuration, C-2
    - timing and digital I/O, C-3 to C-5
- ## R
- RD\* signal
    - description (table), 4-26
    - mode 1 input timing (figure), 4-27
    - mode 2 bidirectional timing (figure), 4-29
  - referenced single-ended input (RSE). *See* RSE (referenced single-ended) mode.
  - register-level programming, 1-6
  - requirements for getting started, 1-2 to 1-3
  - RSE (referenced single-ended) mode
    - configuration, 4-10
    - description (table), 3-2
    - recommended configuration (figure), 4-12
    - single-ended connections for floating signal sources, 4-18
  - RTSI clocks, 3-8
  - RTSI trigger lines
    - overview, 3-8

- pins used by PXI E series board (table), 5-10
- signal connection
  - PCI boards (figure), 3-9
  - PXI boards (figure), 3-10
- specifications, A-9

## S

- sampling rate, C-1
- SCANCLK signal
  - DAQ timing connections, 4-33
  - description (table), 4-5
  - signal summary (table), 4-7
- scanning, multichannel, 3-4 to 3-5
- settling time, in multichannel scanning, 3-5
- signal connections
  - analog input, 4-8 to 4-19
    - common-mode signal rejection considerations, 4-19
    - differential connection considerations, 4-13 to 4-16
    - input modes, 4-9 to 4-11
    - single-ended connection considerations, 4-17 to 4-19
    - summary of input connections (table), 4-12
    - types of signal sources, 4-8 to 4-9
  - analog output, 4-20
  - digital I/O, 4-21
  - field wiring considerations, 4-49 to 4-50
  - I/O connectors, 4-1 to 4-8
    - exceeding maximum ratings (warning), 4-1
    - I/O connector signal descriptions (table), 4-4 to 4-6
    - I/O signal summary (table), 4-7 to 4-8
    - pin assignments (figure), 4-2 to 4-3

- I/O connectors, optional, B-2 to B-6
  - 50-pin E Series connector pin assignments (figure), B-5
  - 50-pin extended digital input connector pin assignments (figure), B-6
  - 68-pin E Series connector pin assignments (figure), B-3
  - 68-pin extended digital input connector pin assignments (figure), B-4
- power connections, 4-30
- Programmable Peripheral Interface
  - 6025E only, 4-22 to 4-23
  - mode 1 input timing (figure), 4-27
  - mode 1 output timing (figure), 4-28
  - mode 2 bidirectional timing (figure), 4-29
  - Port C pin assignments, 4-23
  - power-up state, 4-24 to 4-25
  - signal names used in diagrams (table), 4-25 to 4-26
  - timing specifications, 4-25 to 4-29
- timing connections, 4-30 to 4-49
  - DAQ timing connections, 4-32 to 4-40
  - general-purpose timing signal connections, 4-43 to 4-49
  - programmable function input connections, 4-31 to 4-32
  - waveform generation timing connections, 4-40 to 4-43
- signal sources, 4-8 to 4-9
  - floating signal sources, 4-8 to 4-9
  - ground-referenced signal sources, 4-9
- single-ended connections, 4-17 to 4-19
  - floating signal sources (RSE configuration), 4-18
  - grounded signal sources (NRSE configuration), 4-18 to 4-19
  - when to use, 4-17
- SISOURCE signal, 4-40

- software installation, 2-1
- software programming choices, 1-3 to 1-6
  - ComponentWorks, 1-4
  - LabVIEW and LabWindows/CVI, 1-4
  - National Instruments application software, 1-4
  - NI-DAQ driver software, 1-4 to 1-5
  - register-level programming, 1-6
  - VirtualBench, 1-4
- specifications
  - analog input, A-1 to A-4
    - accuracy information, A-2
    - amplifier characteristics, A-3
    - dynamic characteristics, A-4
    - input characteristics, A-1 to A-2
    - stability, A-4
    - transfer characteristics, A-3
  - analog output, A-4 to A-6
    - accuracy information, A-5
    - dynamic characteristics, A-6
    - output characteristics, A-4 to A-5
    - stability, A-6
    - transfer characteristics, A-5 to A-6
    - voltage output, A-6
  - calibration, A-9
  - digital I/O, A-7 to A-8
    - DIO<0..7>, A-7
    - PA<0..7>, PB<0..7>, PC<0..7>, A-7 to A-8
  - operating environment, A-10
  - physical, A-9 to A-10
  - power requirement, A-9
  - storage environment, A-10
  - timing I/O, A-8
  - triggers, A-9
    - digital trigger, A-9
    - RTSI trigger, A-9
- STARTSCAN signal, 4-36 to 4-38

- STB\* signal
  - description (table), 4-25
  - mode 1 input timing (figure), 4-27
  - mode 2 bidirectional timing (figure), 4-29
- storage environment specifications, A-10

## T

- technical support, D-1 to D-2
- telephone and fax support numbers, D-2
- timing connections, 4-30 to 4-49
  - DAQ timing connections, 4-32 to 4-40
    - AIGATE signal, 4-39
    - CONVERT\* signal, 4-38 to 4-39
    - EXTSTROBE\* signal, 4-33 to 4-34
    - SCANCLK signal, 4-33
    - SISOURCE signal, 4-40
    - STARTSCAN signal, 4-36 to 4-38
    - TRIG1 signal, 4-34 to 4-35
    - TRIG2 signal, 4-35 to 4-36
    - typical posttriggered acquisition (figure), 4-32
    - typical pretriggered acquisition (figure), 4-33
  - general-purpose timing signal connections, 4-43 to 4-49
    - FREQ\_OUT signal, 4-49
    - GPCTR0\_GATE signal, 4-44
    - GPCTR0\_OUT signal, 4-45
    - GPCTR0\_SOURCE signal, 4-43 to 4-44
    - GPCTR0\_UP\_DOWN signal, 4-45
    - GPCTR1\_GATE signal, 4-46 to 4-47
    - GPCTR1\_OUT signal, 4-47
    - GPCTR1\_SOURCE signal, 4-45 to 4-46
    - GPCTR1\_UP\_DOWN signal, 4-47 to 4-49
- overview, 4-30
- programmable function input connections, 4-31 to 4-32

- timing I/O connections (figure), 4-31
- waveform generation timing connections, 4-40 to 4-43
  - UISOURCE signal, 4-42 to 4-43
  - UPDATE\* signal, 4-41 to 4-42
  - WFTRIG signal, 4-40 to 4-41
- timing I/O
  - common questions, C-3 to C-5
  - specifications, A-8
- timing signal routing, 3-6 to 3-10
  - board and RTSI clocks, 3-8
  - CONVERT\* signal routing (figure), 3-7
  - programmable function inputs, 3-7 to 3-8
  - RTSI triggers, 3-8 to 3-10
- timing specifications, 4-25 to 4-29
  - mode 1 input timing (figure), 4-27
  - mode 1 output timing (figure), 4-28
  - mode 2 bidirectional timing (figure), 4-29
  - signal names used in diagrams (table), 4-25 to 4-26
- TRIG1 signal, 4-34 to 4-35
- TRIG2 signal, 4-35 to 4-36
- trigger specifications, A-9
  - digital trigger, A-9
  - RTSI trigger, A-9
- triggers, RTSI. *See* RTSI trigger lines.

## U

- UISOURCE signal, 4-42 to 4-43
- unpacking 6023E/6024E/6025E, 1-3
- UPDATE\* signal, 4-41 to 4-42

## V

- VCC signal (table), 4-7
- VirtualBench software, 1-4
- voltage output specifications, A-6

## W

- waveform generation, questions about, C-2 to C-3
- waveform generation timing connections, 4-40 to 4-43
  - UISOURCE signal, 4-42 to 4-43
  - UPDATE\* signal, 4-41 to 4-42
  - WFTRIG signal, 4-40 to 4-41
- WFTRIG signal, 4-40 to 4-41
- WR\* signal
  - description (table), 4-26
  - mode 1 output timing (figure), 4-28
  - mode 2 bidirectional timing (figure), 4-29